

PRESS BRAKE SOLUTIONS



BENDMAX(NAN JING) MACHINE TOOL CO.LTD.

Email:jason@bendmax.com

Web:www.bendmax.com

Add: Building 3, No. 56 Youshan Road, Gaochun Economic Development Zone,
Nanjing City, Jiangsu Province



ABOUT US



Enterprise Overview

Bendmax(Nan jing) machine tool Co.Ltd.

We are a specialized factory with 18 years of experience in manufacturing and selling high-precision bending tools. Our expertise and dedication to innovation ensure top-quality products that meet the highest industry standards.

At **BENDMAX**, we continuously enhance our technology and production processes to guarantee accuracy, durability, and strong compatibility in every tool we produce. Each bending tool undergoes rigorous quality control and testing to ensure reliability and performance.

Our team comprises highly skilled engineers, technicians, and production experts who are committed to delivering customized solutions tailored to your specific needs. We aim to build long-term partnerships with our customers and be your trusted supplier of bending tools.

Contact us today to learn more about our products and services. We look forward to working with you and providing precision & efficiency in every bend!



Product Index

01

Introduction 01-02

02

Hydraulic Upper Clamping 03

03

Hydraulic Lower Clamping 04

04

Hydraulic Crowning Table 05

05

Hydraulic Power Unit 07-08

06

BENDMAX-Wila Style 09-32

07

BENDMAX-European Style 33-78

08

Force Parameter 79

Clamping Feature

Introduction

- The clamping body is made of hardened high-strength alloy steel, the hardness is about hrc30, the use of more wear-resistant.
- The special hydraulic expansion pipe has super tensile and fatigue resistance, longer service life.
- The self-designed expansion pipe joint is more convenient to use, while improving the expansion pipe explosion risk.
- The clamping body is integrated processing to ensure dimensional accuracy and form and position tolerance.
- One-button control, so that the mold automatically clamping, centering.
- Support mold positive and negative installation, vertical and horizontal loading and unloading mold.
- The evenly distributed clamping force offsets the lateral force during bending, and the use is more stable.
- Support the safety button and safety pin mold, will not fall when released, to avoid safety accidents.

Building Rule

1 H= Hydraulic

2 W=WILA

3 P=Punch D=Die

4 = Mounting Style

UPB=Universal Press Brake

ES1= European Style I

ES2= European Style II

ES60= European 60mm

5 = Parts NO.

2381=ES1 Upper Clamping

2386=UPB Upper Clamping

2382= ES2 Upper Clamping

2396= UPB Lower Clamping

2365=ES60 Lower Clamping

2397=UPB Crowing Table

6 = Length

1020

1275

1530

2040

2550

3060

3230

4080

4590

5100

6120

For Example

Clamping Guide

H W P - UPB 2386 - 2040

1 2 3 - 4 - 5 - 6

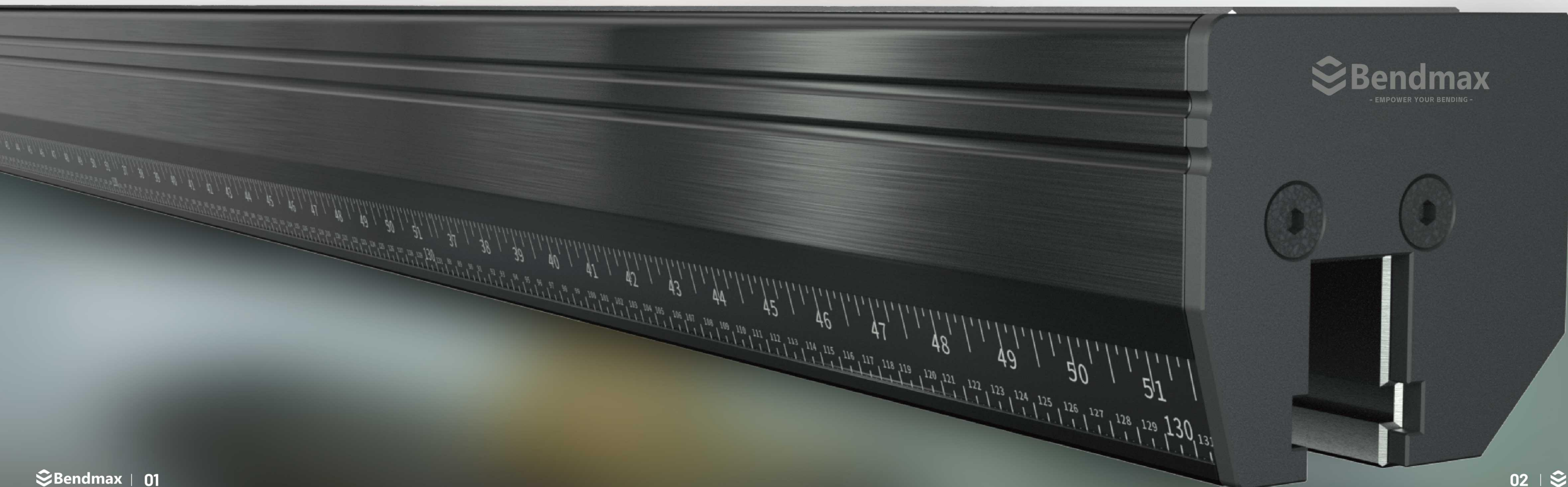

Hydraulic Upper Clamping

Introduction

Hydraulic upper clamping through the expansion of hydraulic oil on the tubing, push the clamping pin to move, so as to clamp and loosen the bending mold, greatly improve the mold change time, reduce the work intensity. A variety of mounting joints are available for upgrading old and new bending machines to hydraulic clamping functions.

Technical Parameters

Clamping mode	Hydraulic	Maximum working oil temperature	70°
Mounting style	UPB	Minimum mold width	15mm
Front cover	Scale	Maximum load head	180T/M
Adjustment mode	Tx adjustment	Maximum shoulder load	250T/M
Hydraulic connector	M14x1.5x74°	Tensile strength	>1000Mpa
Working pressure	35-50kg		

Hydraulic Upper Clamping

Introduction

Hydraulic upper clamping through the expansion of hydraulic oil on the tubing, push the clamping pin to move, so as to clamp and loosen the bending mold, greatly improve the mold change time, reduce the work intensity. A variety of mounting joints are available for upgrading old and new bending machines to hydraulic clamping functions.

Technical Parameters

Clamping mode	Hydraulic	Maximum working oil temperature	70°
Mounting style	ES1/ES2	Minimum mold width	15mm
Front cover	Scale	Maximum load head	180T/M
Hydraulic connector	M14x1.5x74°	Maximum shoulder load	250T/M
Working pressure	35-50kg	Tensile strength	>1000Mpa

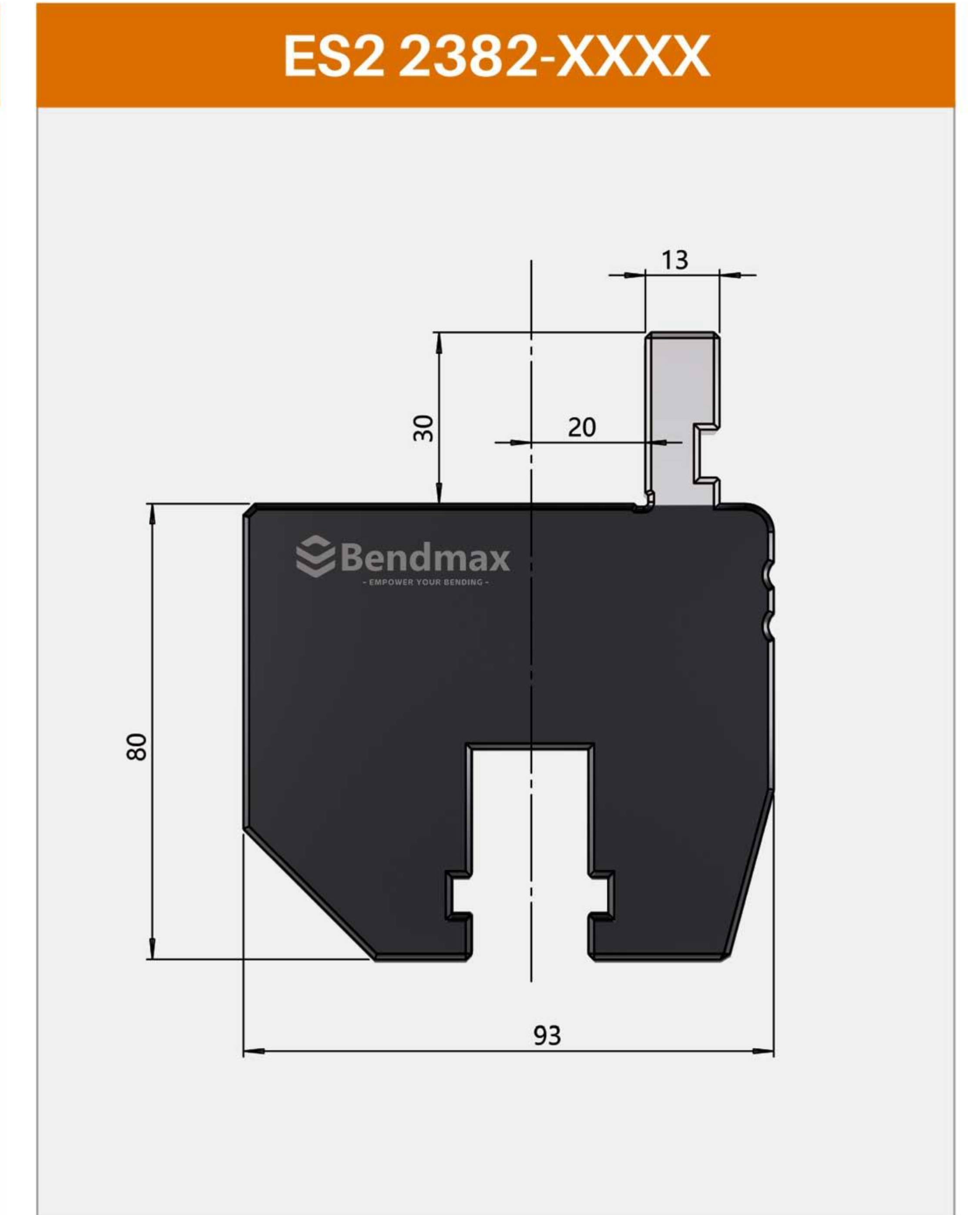
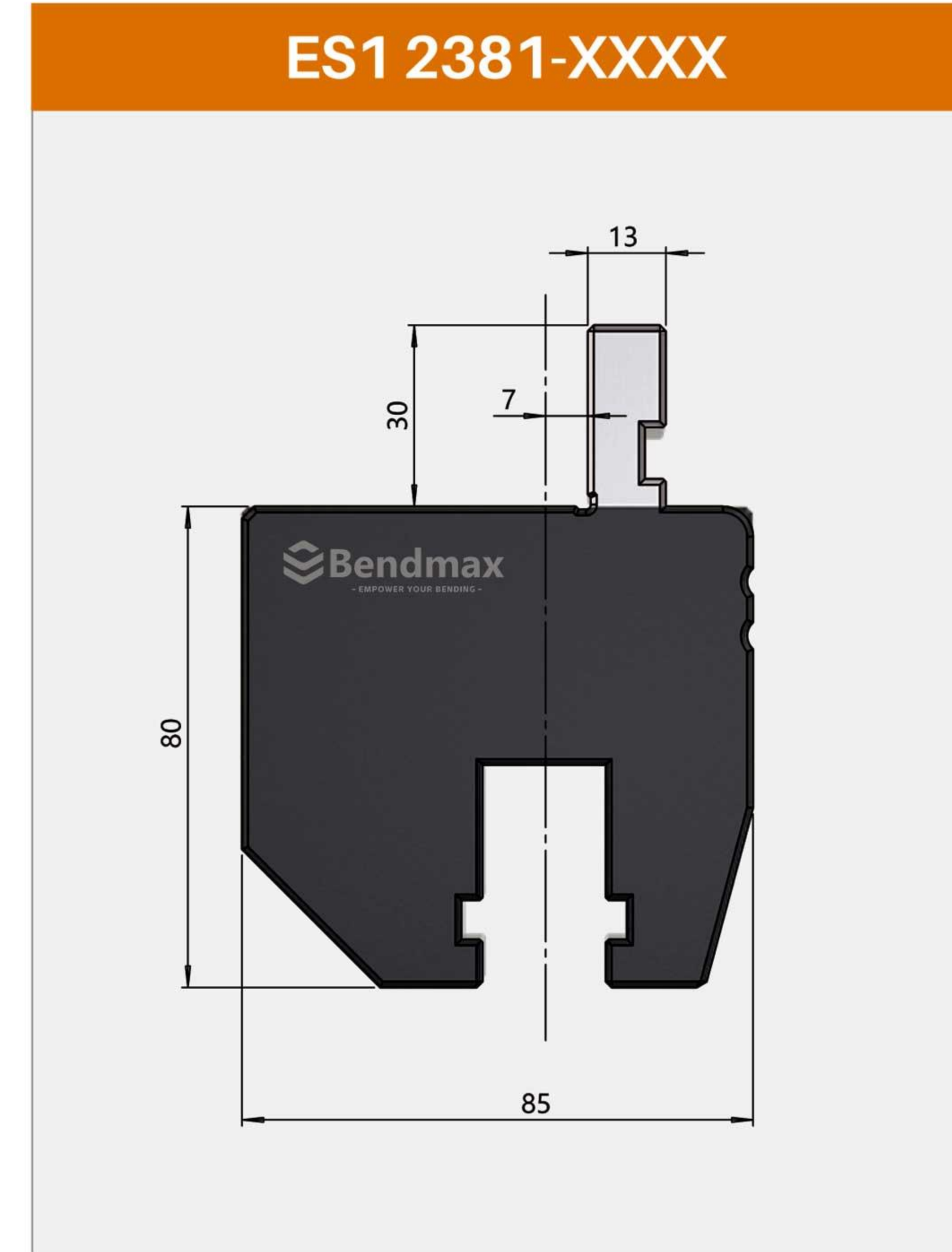
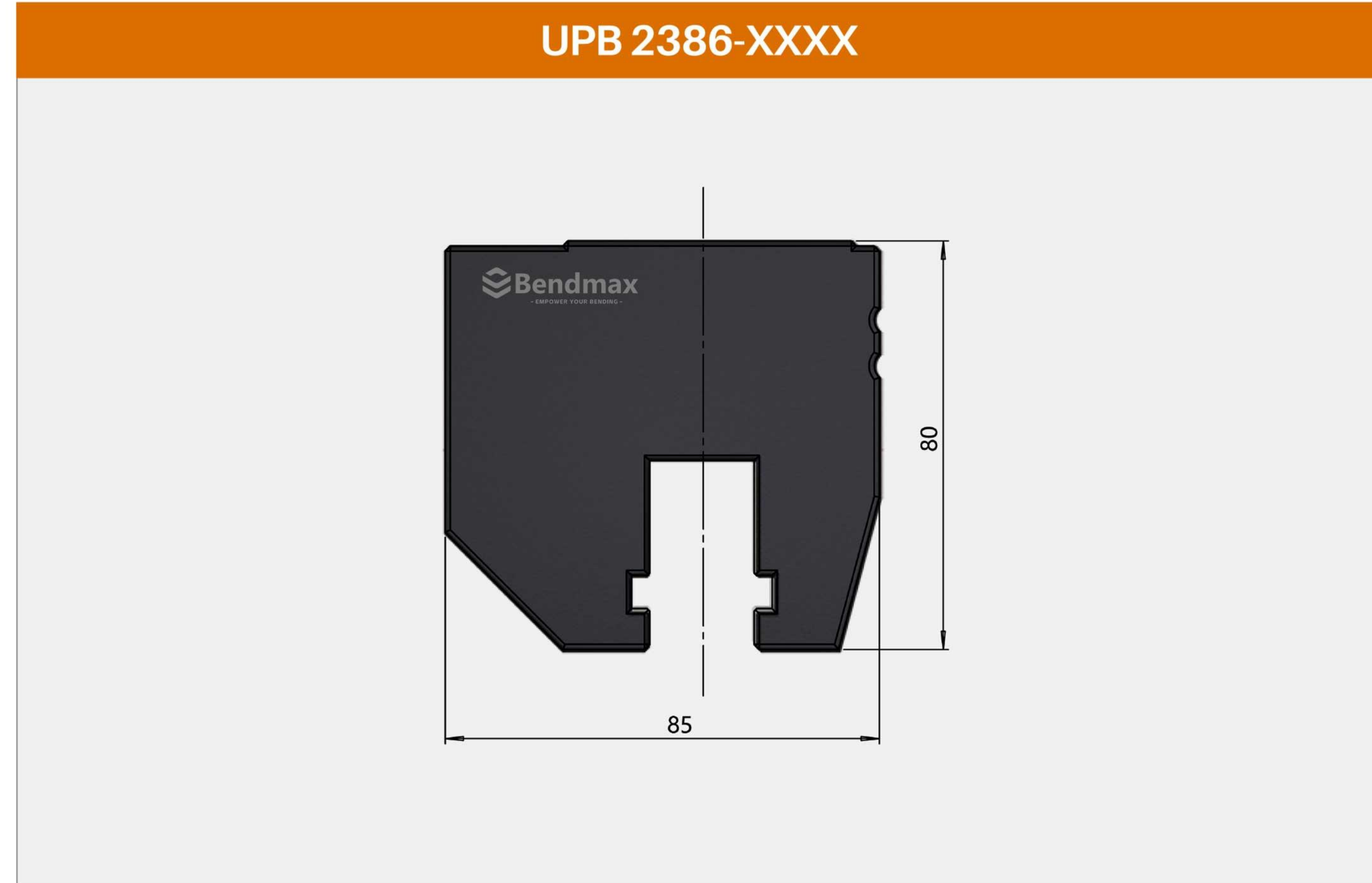

Hydraulic Lower Clamping

Introduction

Hydraulic lower clamping pushes the clamping pin to move through the expansion of the hydraulic oil to the oil pipe, thus clamping and unclamping the bending molds, which dramatically improves the mold change time and reduces the work intensity. For new and old bending machines upgraded to the hydraulic clamping function, a variety of mounting connectors are available.

Technical Parameters

Clamping method	Hydraulic
Mounting style	UPB/ES 60
Main body	Scale
Hydraulic connector	M14x1.5x74°
Working pressure	35-50kg

Maximum working oil temperature	70°
Minimum mold width	15mm
Maximum load shoulder	200T/M
Tensile strength	>1000Mpa

UPB 2369-XXXX

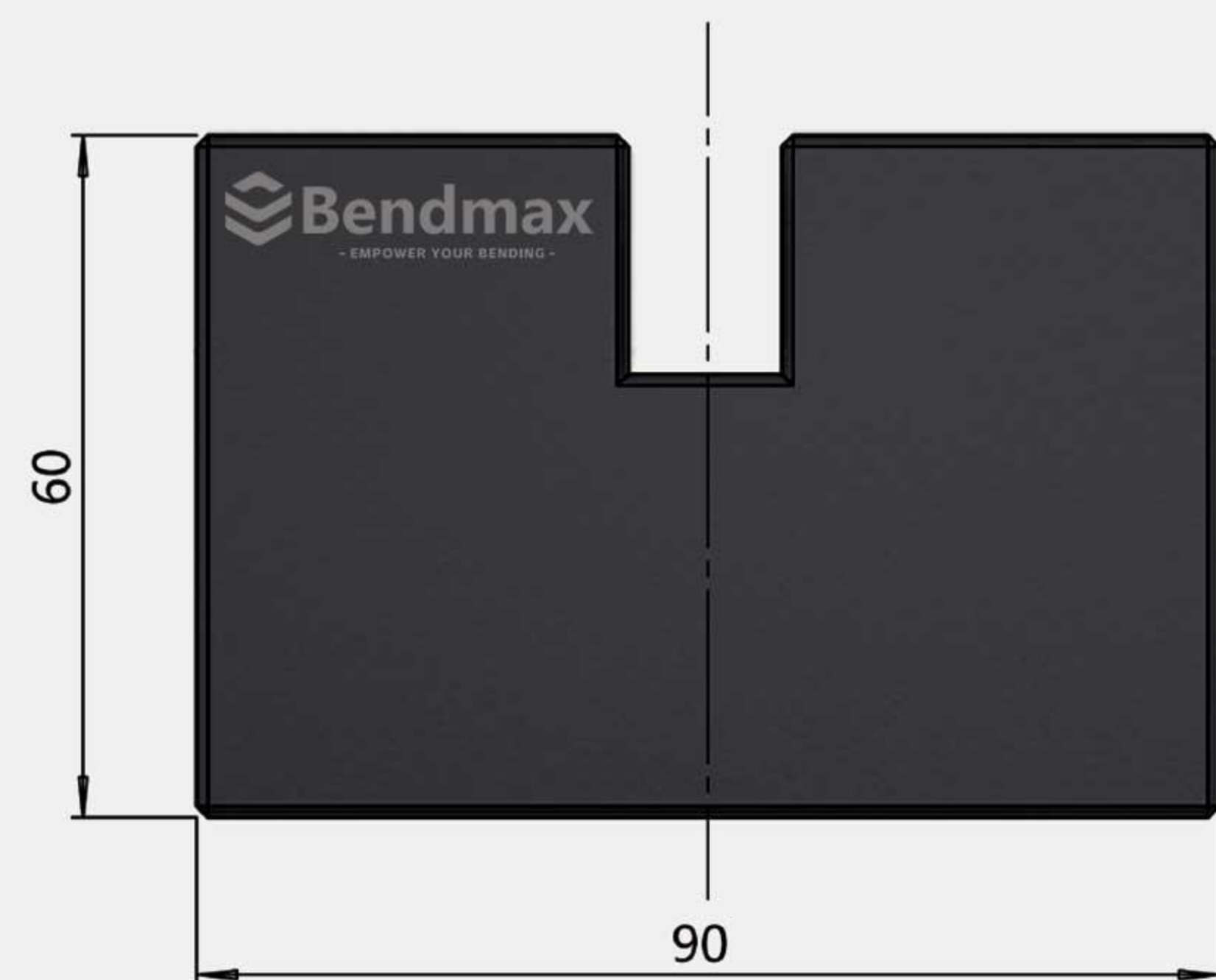

ES60 2365-XXXX

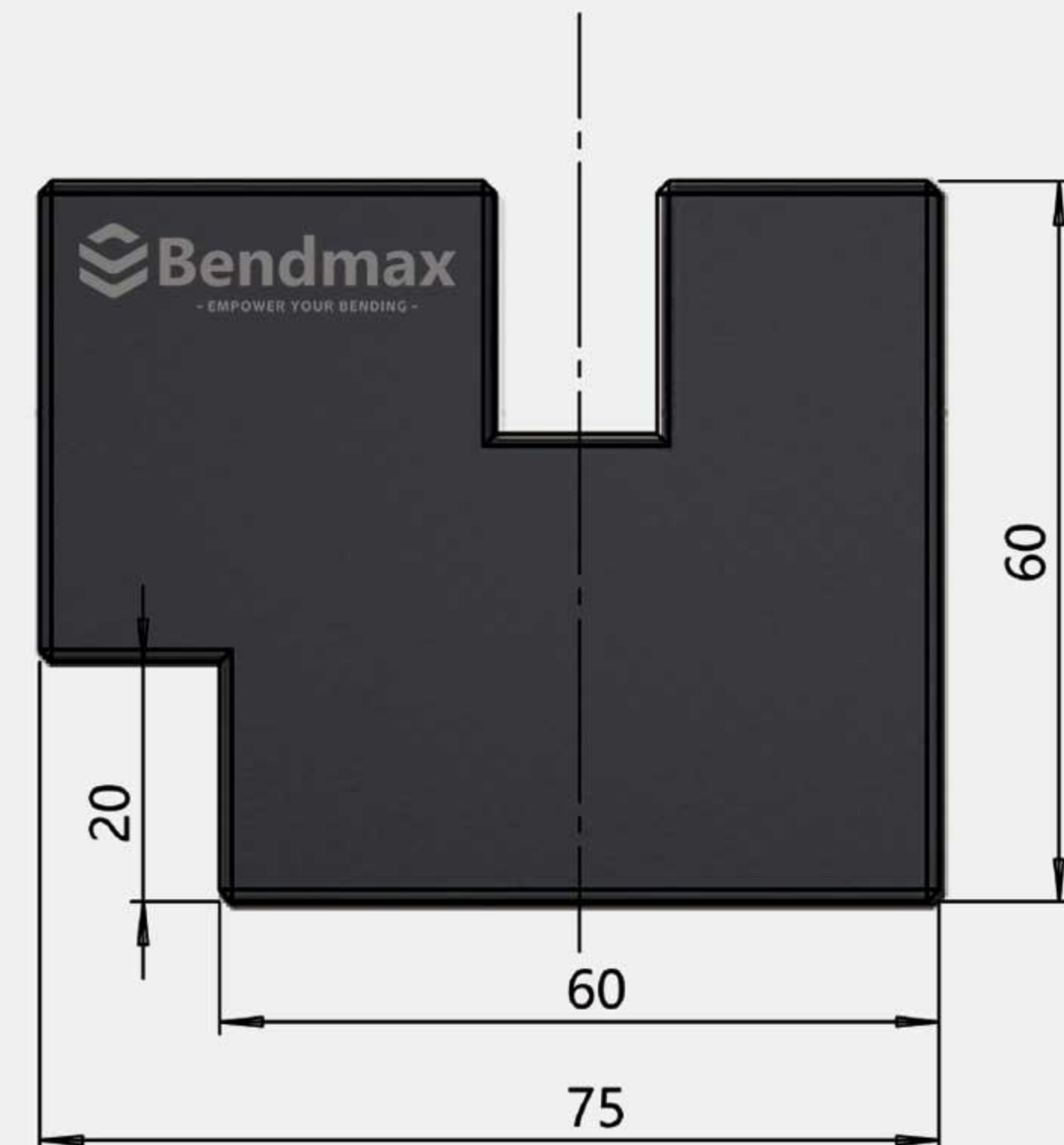

2397-XXXX



Hydraulic Crowning Table

Introduction

The hydraulic compensation table pushes the clamping pin to move through the expansion of the hydraulic oil to the oil pipe, thus clamping and loosening the bending mold, which greatly improves the time of mold change and reduces the work intensity. The disturbance compensation of the bending machine is compensated by the wave-shaped inclined block, which ensures the consistency of the angle of the bending workpiece.

Technical Parameters

Clamping mode	Hydraulic
Mounting style	UPB
Front cover	Scale
Adjustment mode	Tx and Ty two-way adjustment
Hydraulic connector	M14x1.5x74°

Working pressure	35-50kg
Maximum working oil temperature	70°
Minimum mold width	15mm
Maximum shoulder load	200T/M
Tensile strength	>1000Mpa

Hydraulic Power Unit



Introduction

As a power source required for hydraulic clamping, the hydraulic station requires a stable output to maintain the pressure between 3-5 Mpa at all times. Ensure proper clamping operation. This hydraulic station is equipped with wireless remote control, which is convenient to use. The base of the hydraulic station is equipped with shock-absorbing rubber pads for easy movement. Moving and handling.

Technical Parameters

Power supply	Three-phase, 380V, 50/60HZ
Motor power	0.75KW
Fuel tank capacity	4L
System pressure	3-8Mpa (adjustable)
Set pressure value	3-5Mpa (low pressure automatically start to make up the pressure)
Random accessories	M14x1.5x74 ° pipe fitting hydraulic pipe (length 2M)

Power supply	P/N
230V,50/60HZ	2396-S-230V/50/60
380V,50/60HZ	2396-S-380V/50/60
460V,50/60HZ	2396-S-480V/50/60
575V,50/60HZ	2396-S-575V/50/60

Punches Information

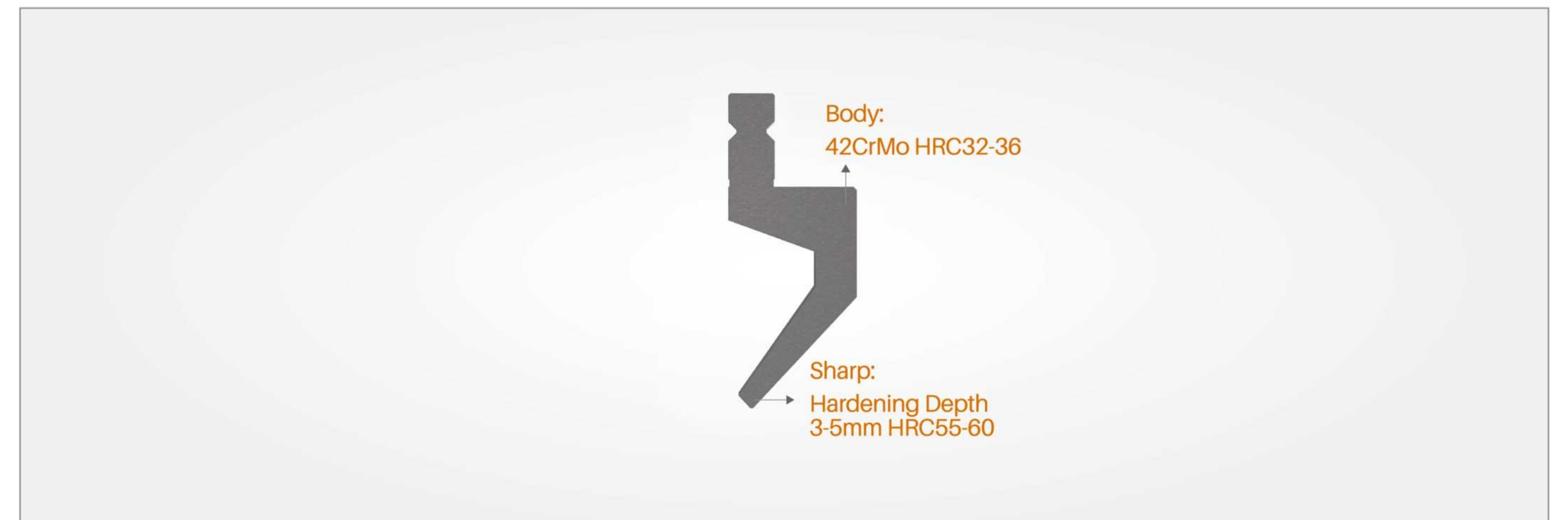
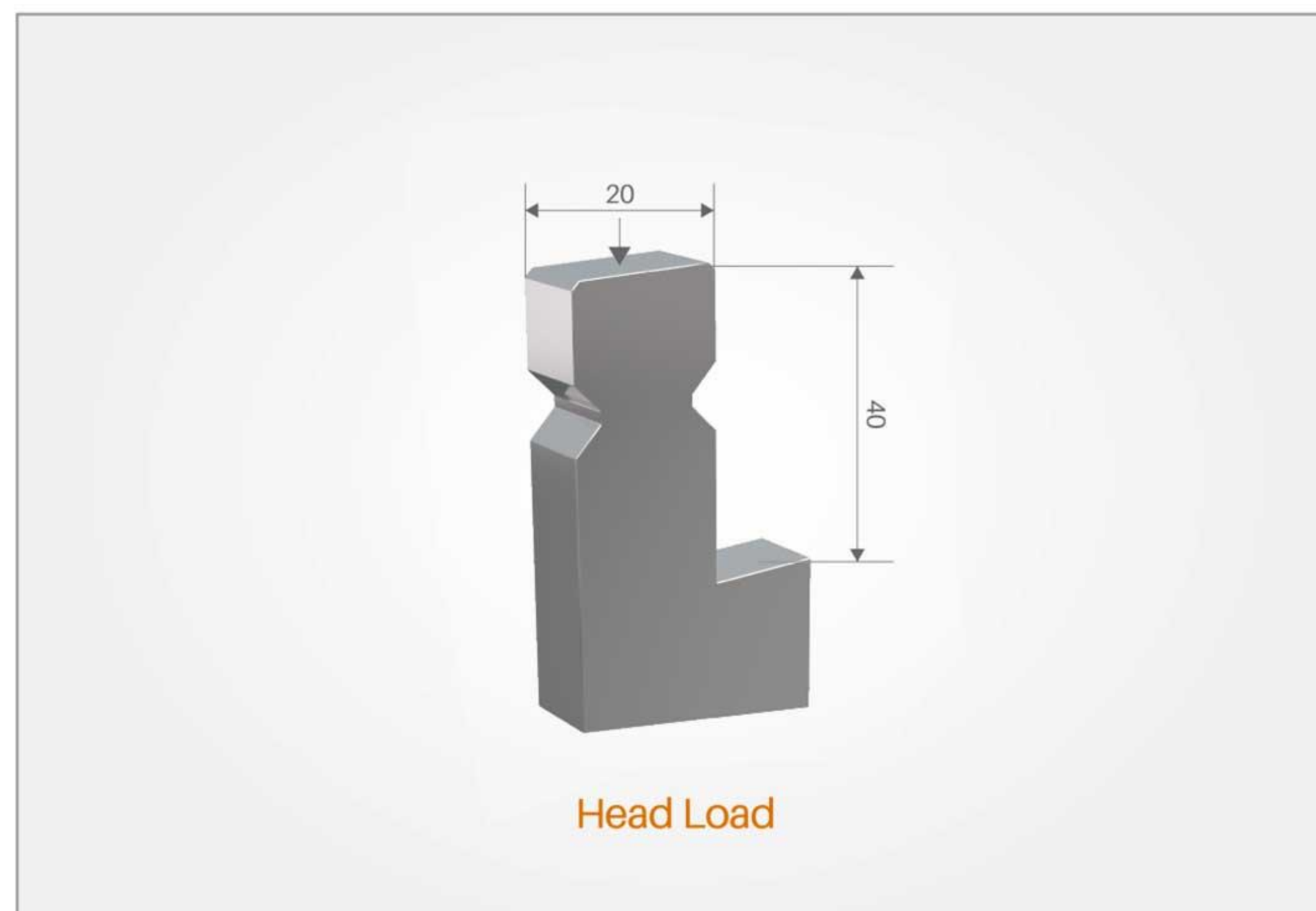
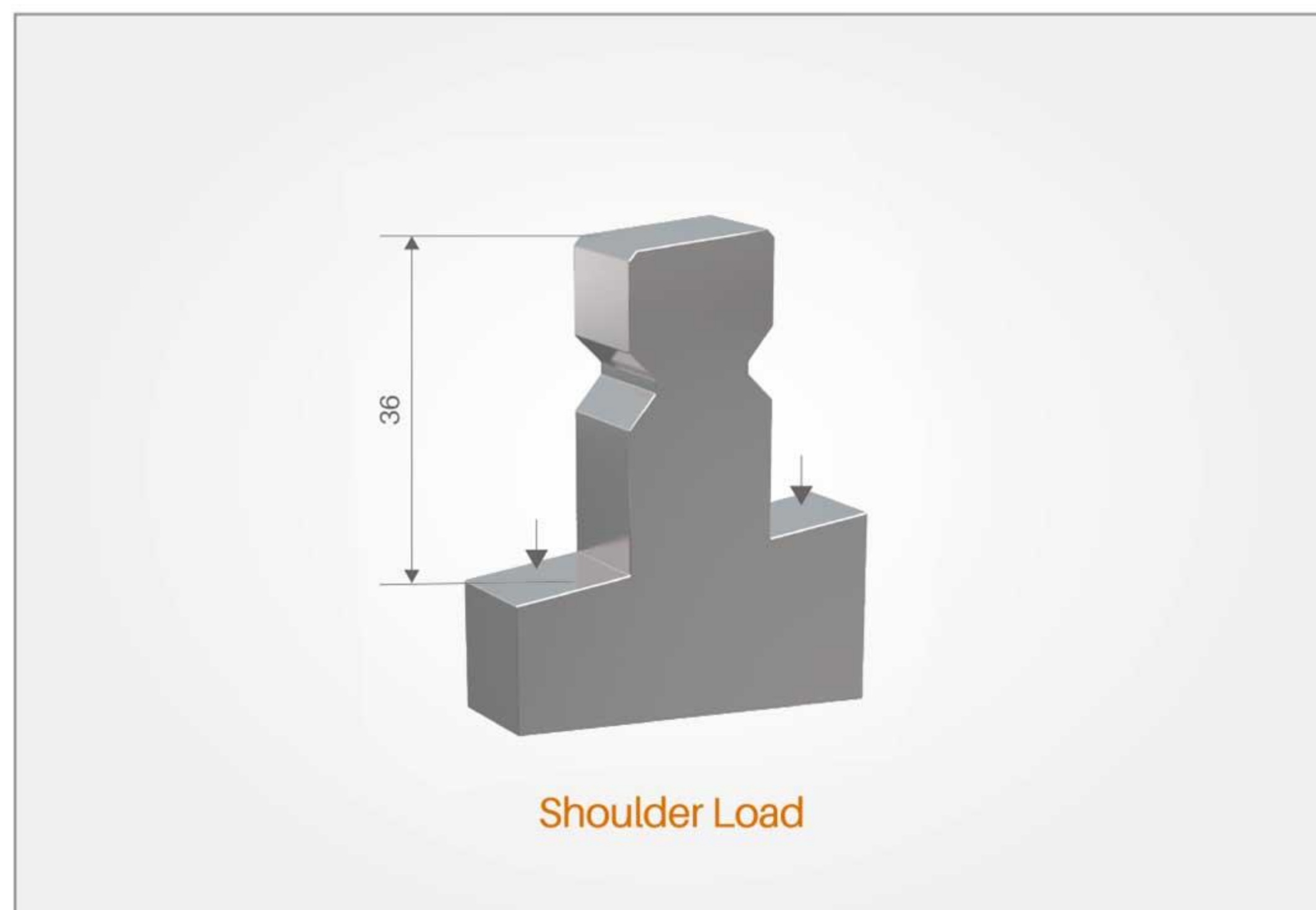
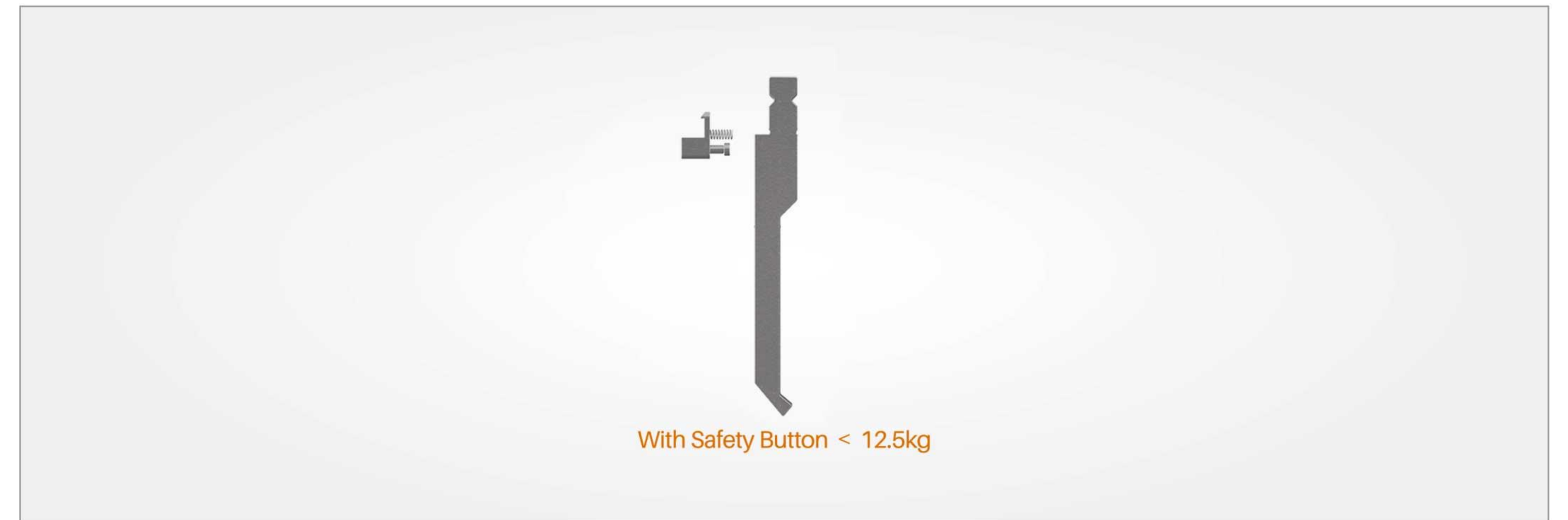
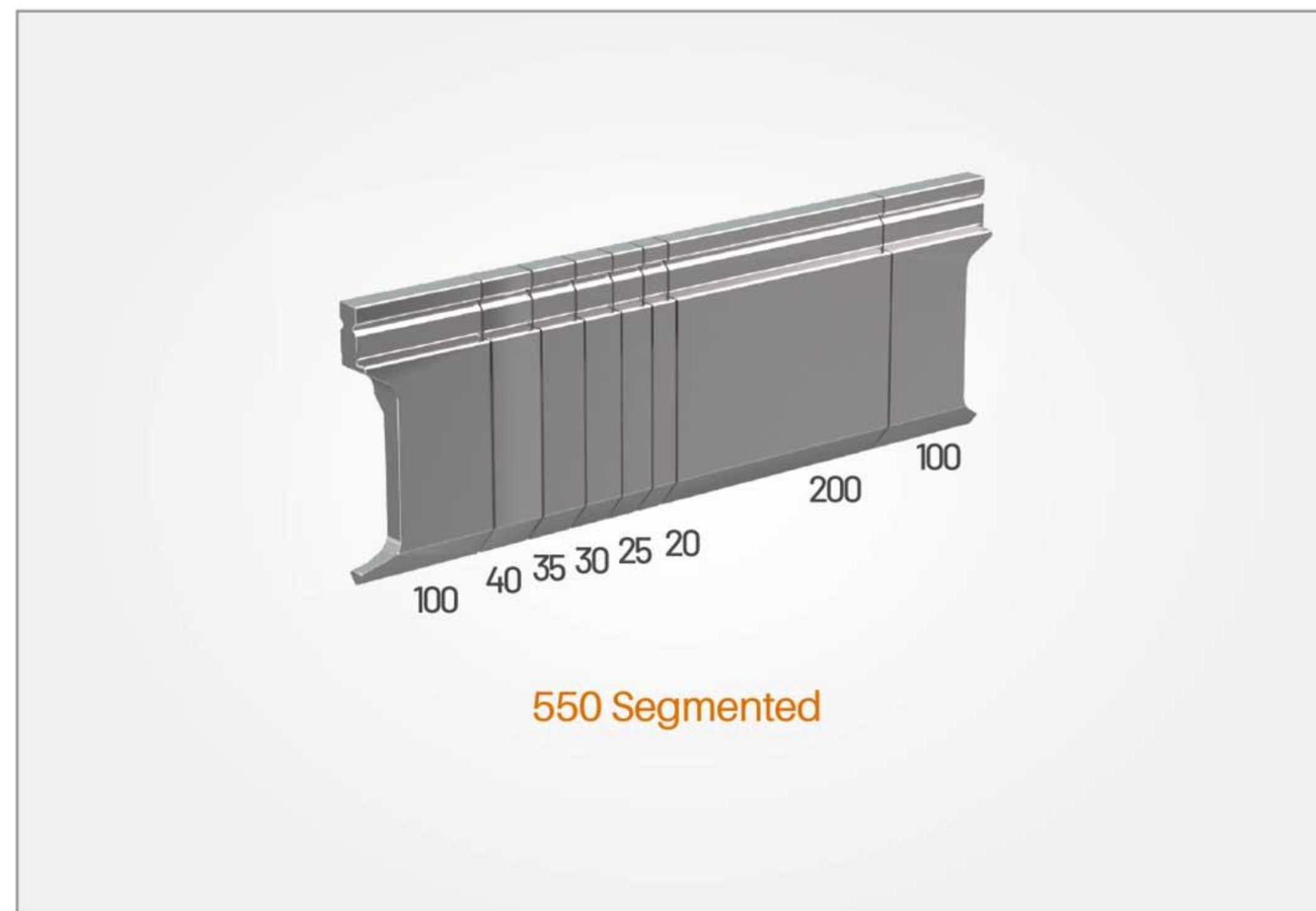
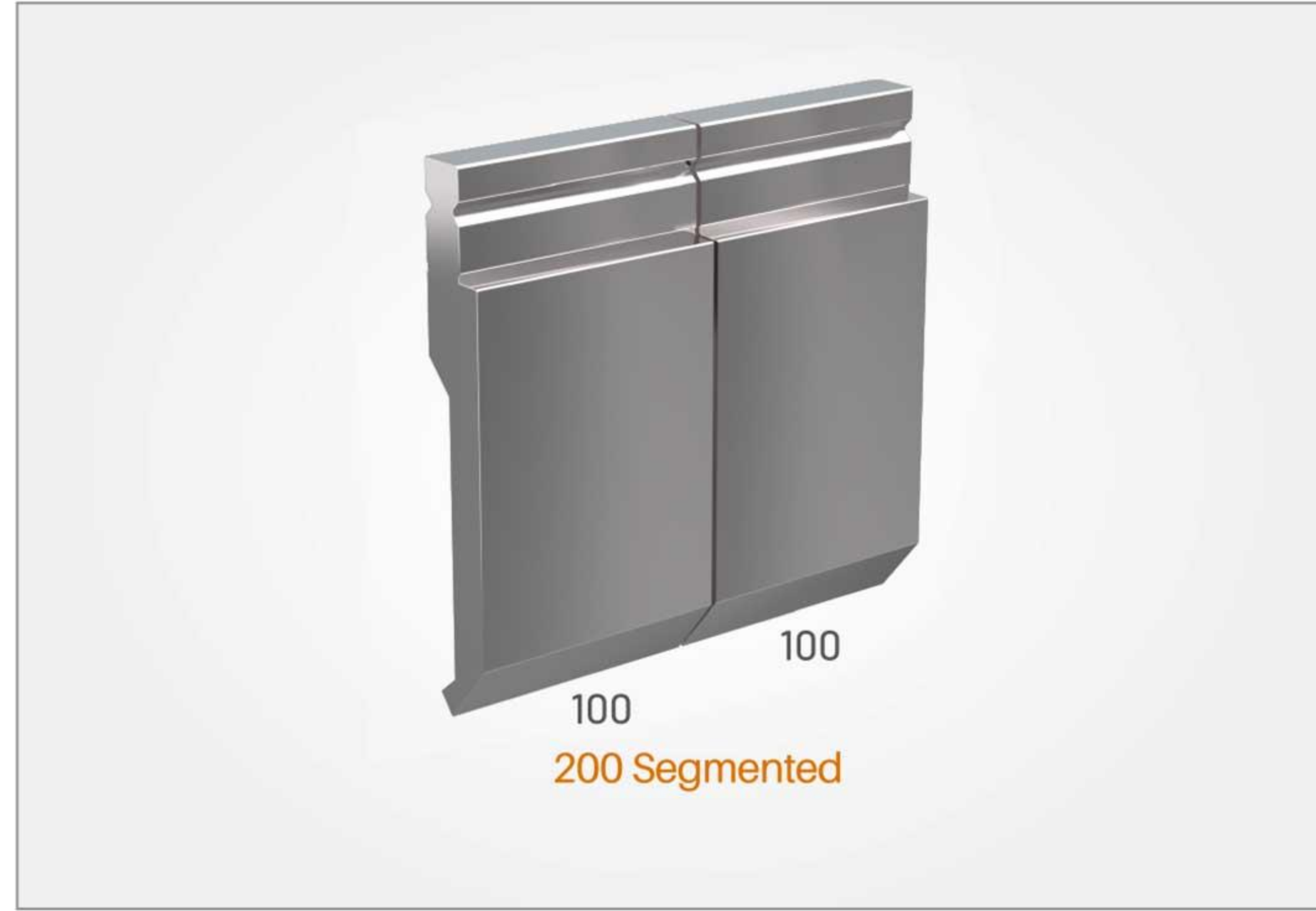
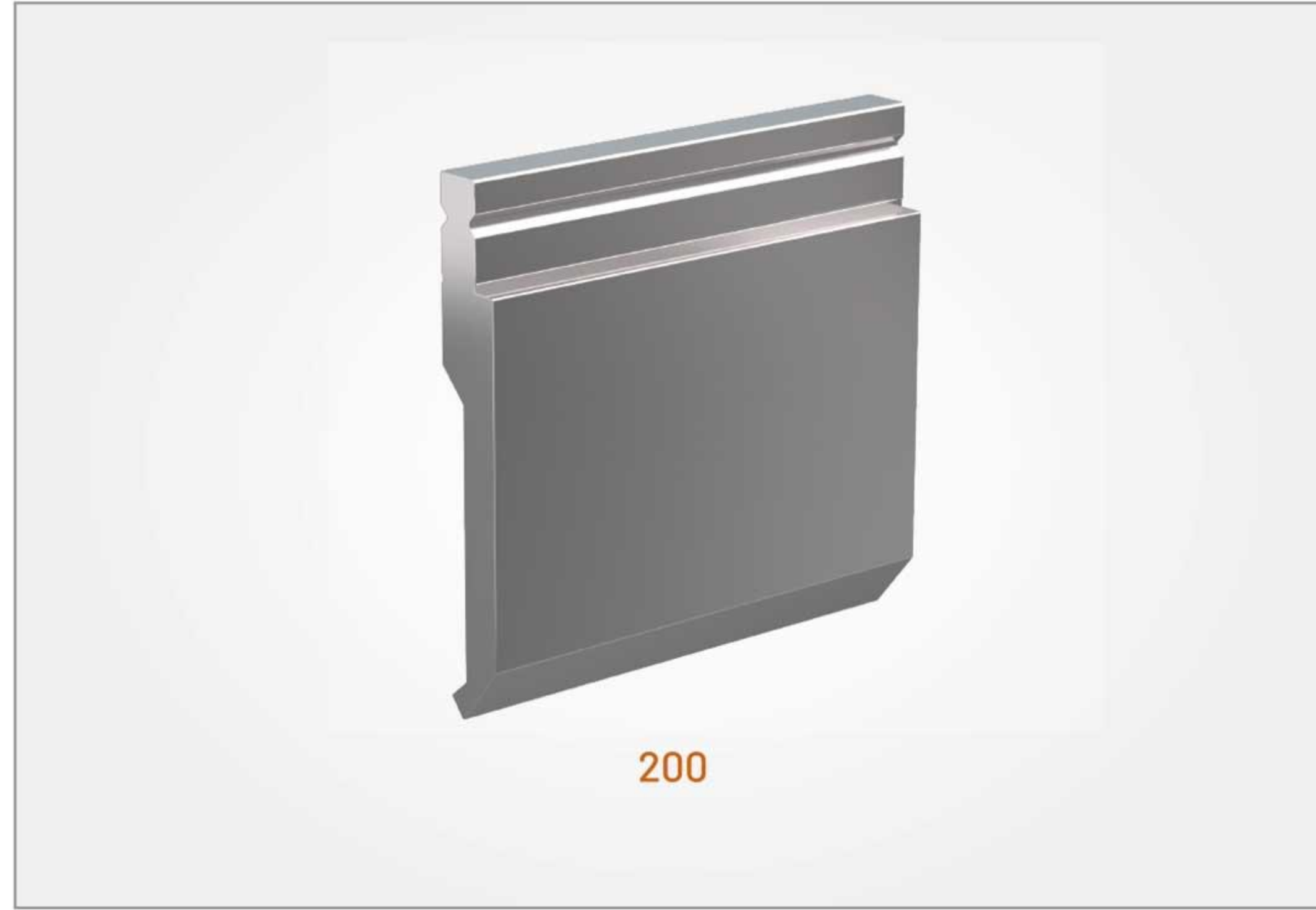



Punches-Height 135

PRESSBRAKE TOOLS-BENDMAX-WILASTYLE

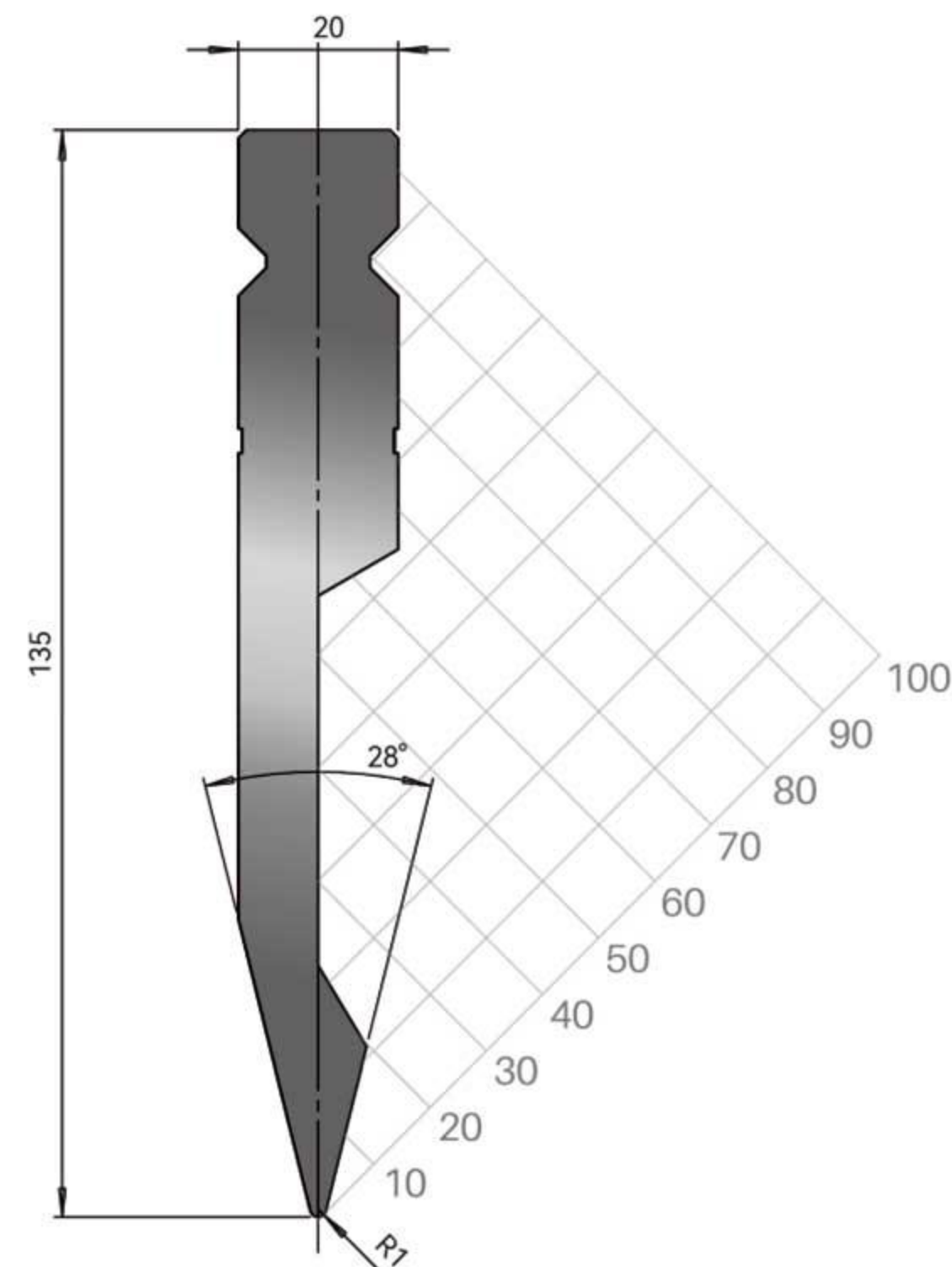

ZWP001

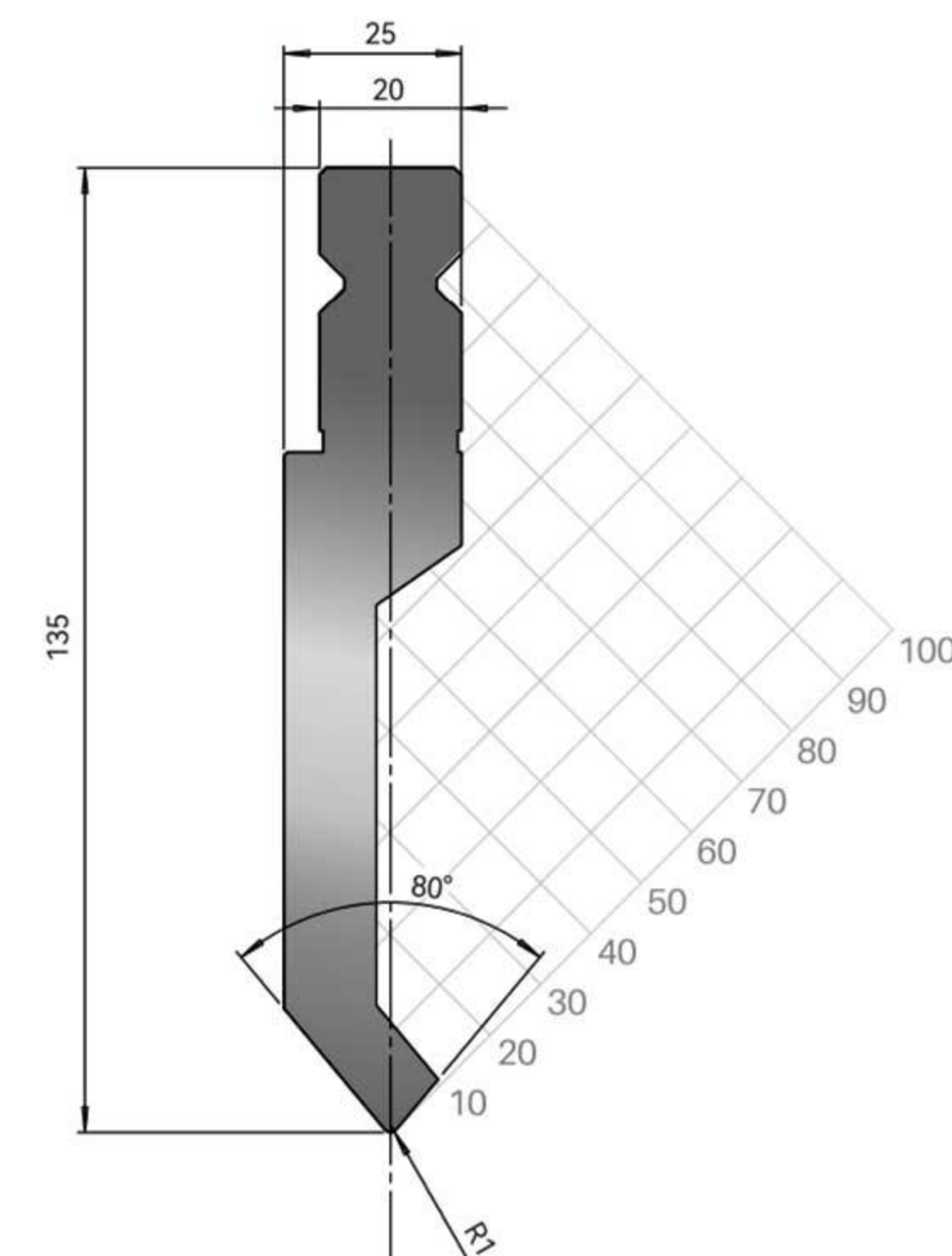

ZWP002

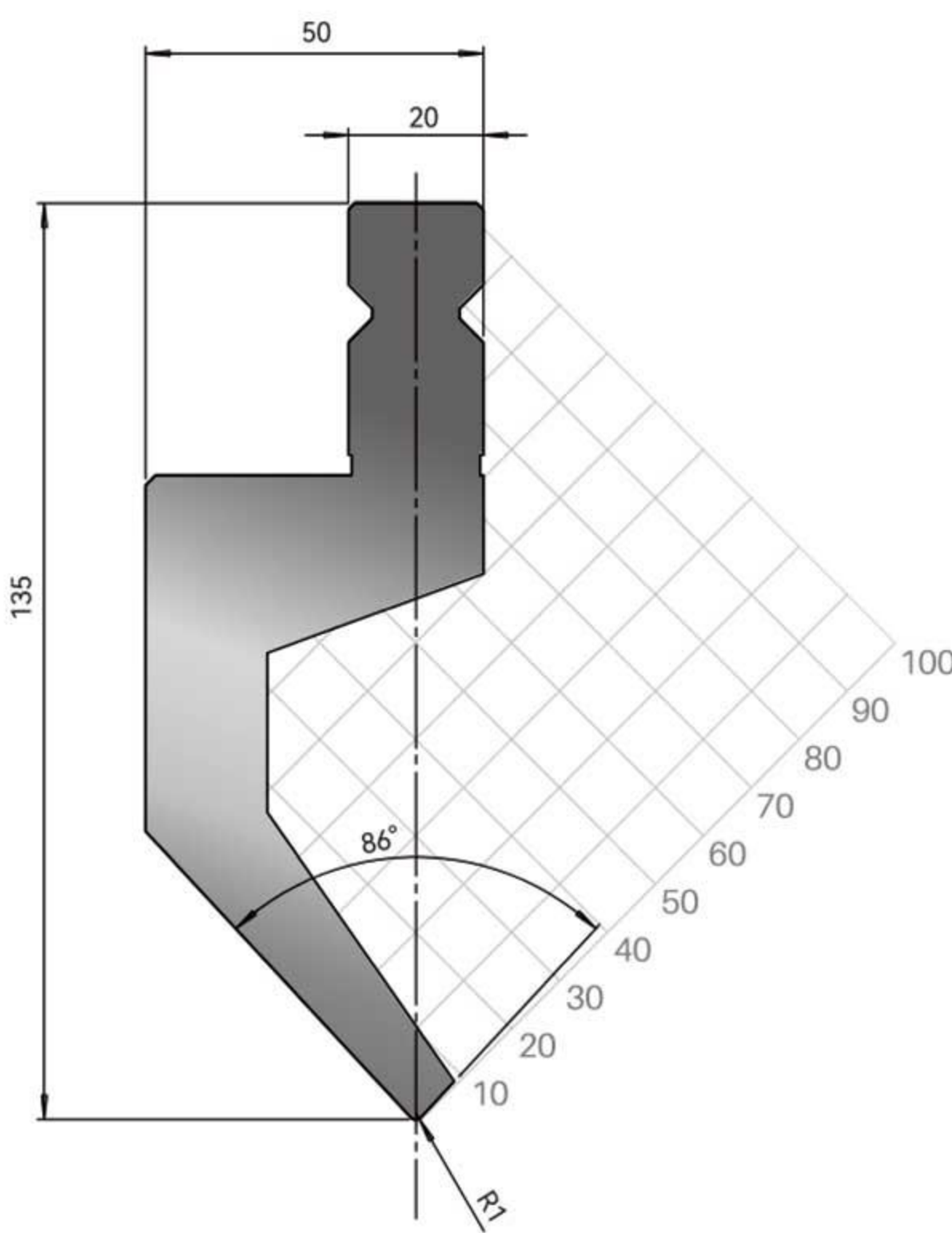

ZWP003

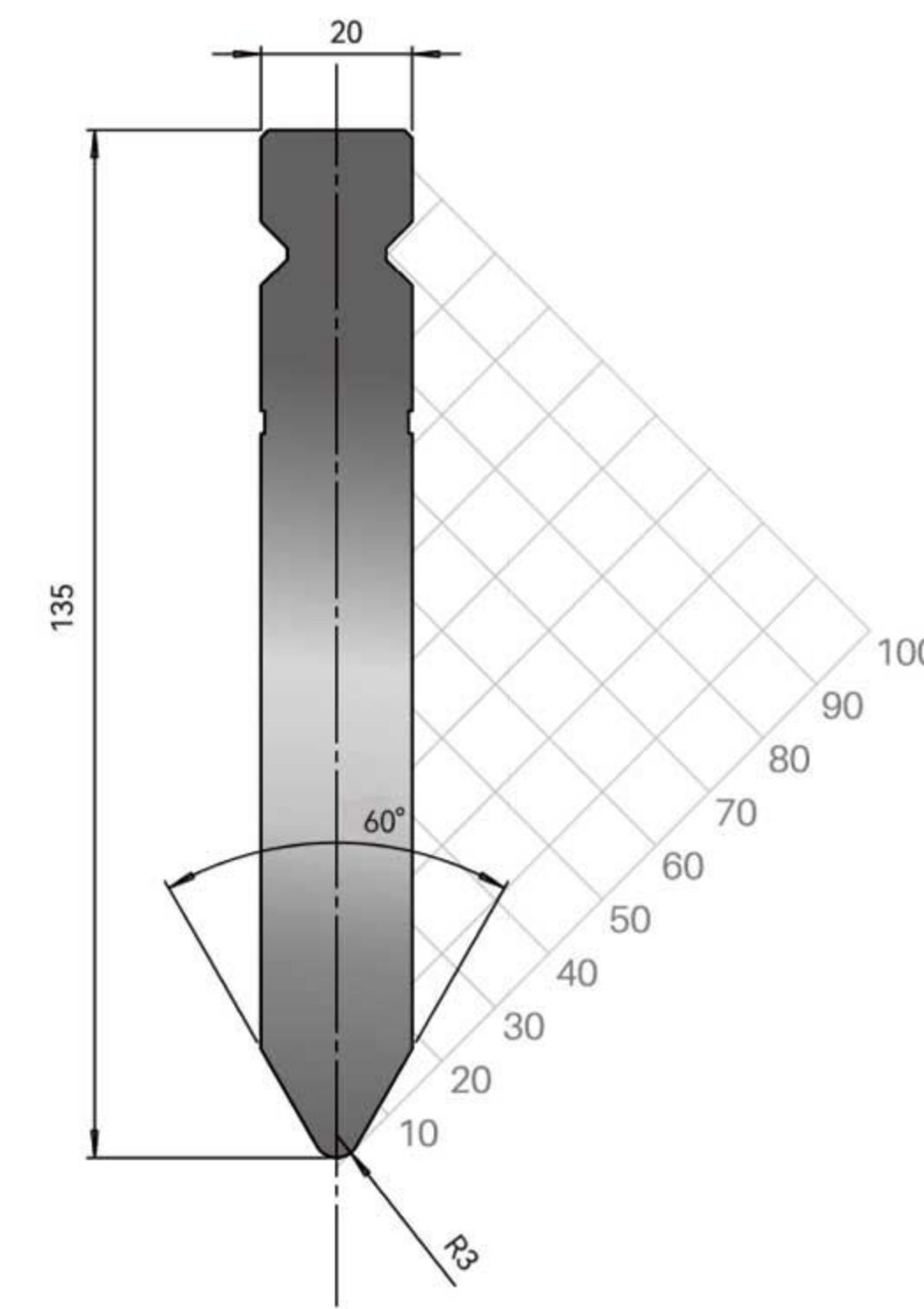

ZWP004

BENDMAX CAT.NO	WILA CAT.NO	Max Loading (t/m)	Weight (kg/m)
ZWP001	BIU-001	100	14.5
ZWP002	BIU-002	100	17.5
ZWP003	BIU-003	65	24
ZWP004	BIU-004	160	20.5



Punches-Height 157

PRESSBRAKE TOOLS-BENDMAX-WILASTYLE

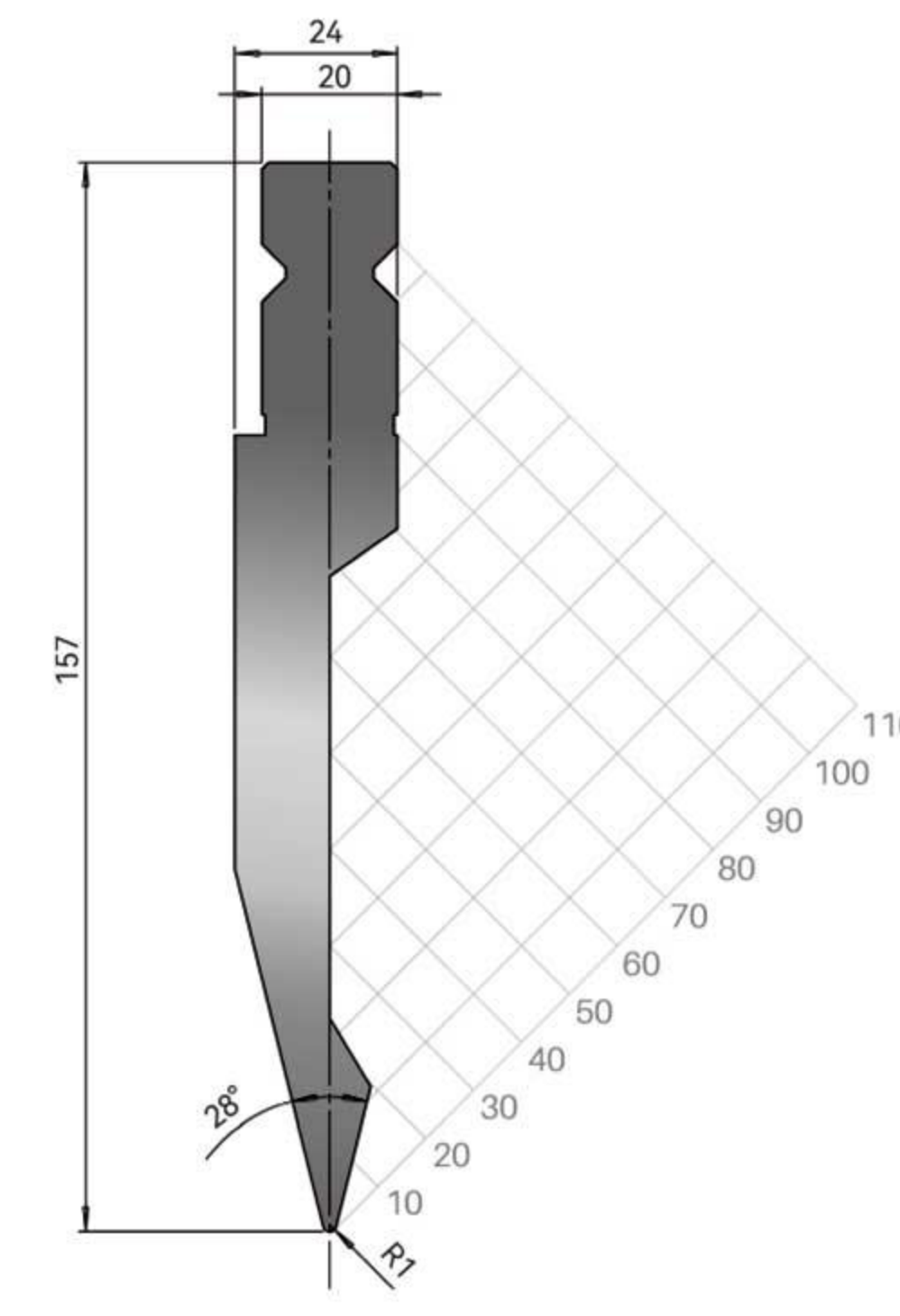

ZWP011

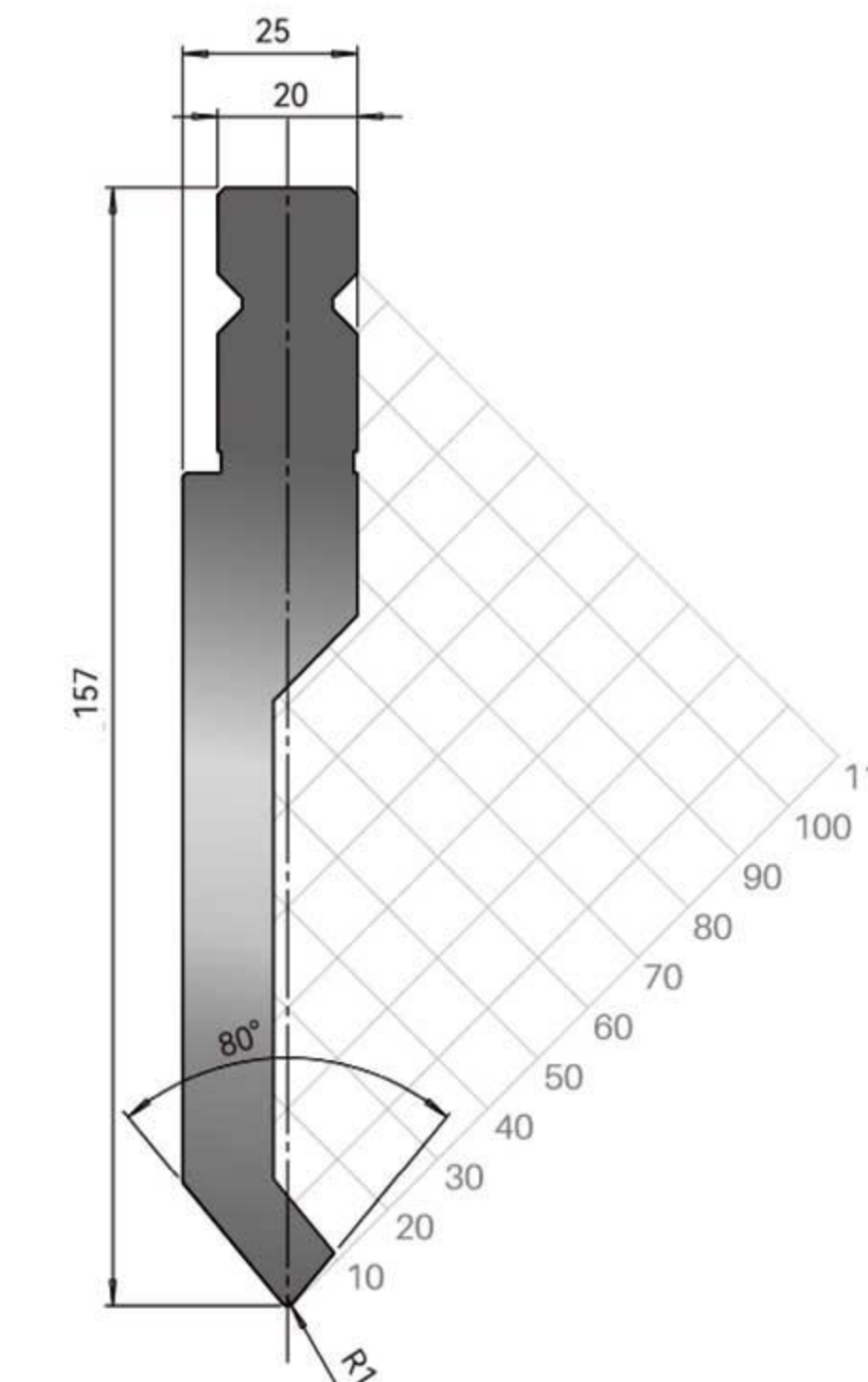

ZWP012

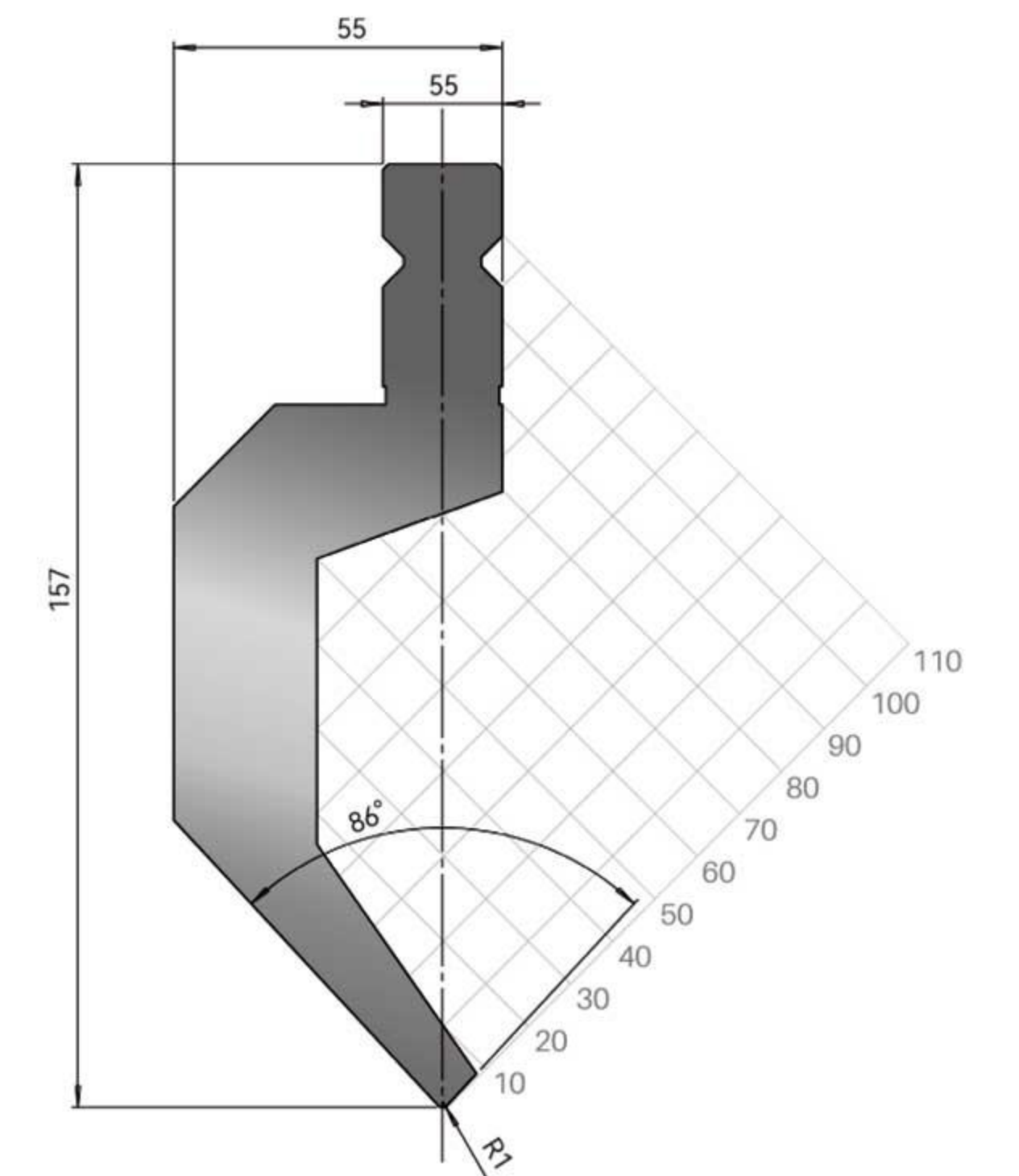

ZWP013

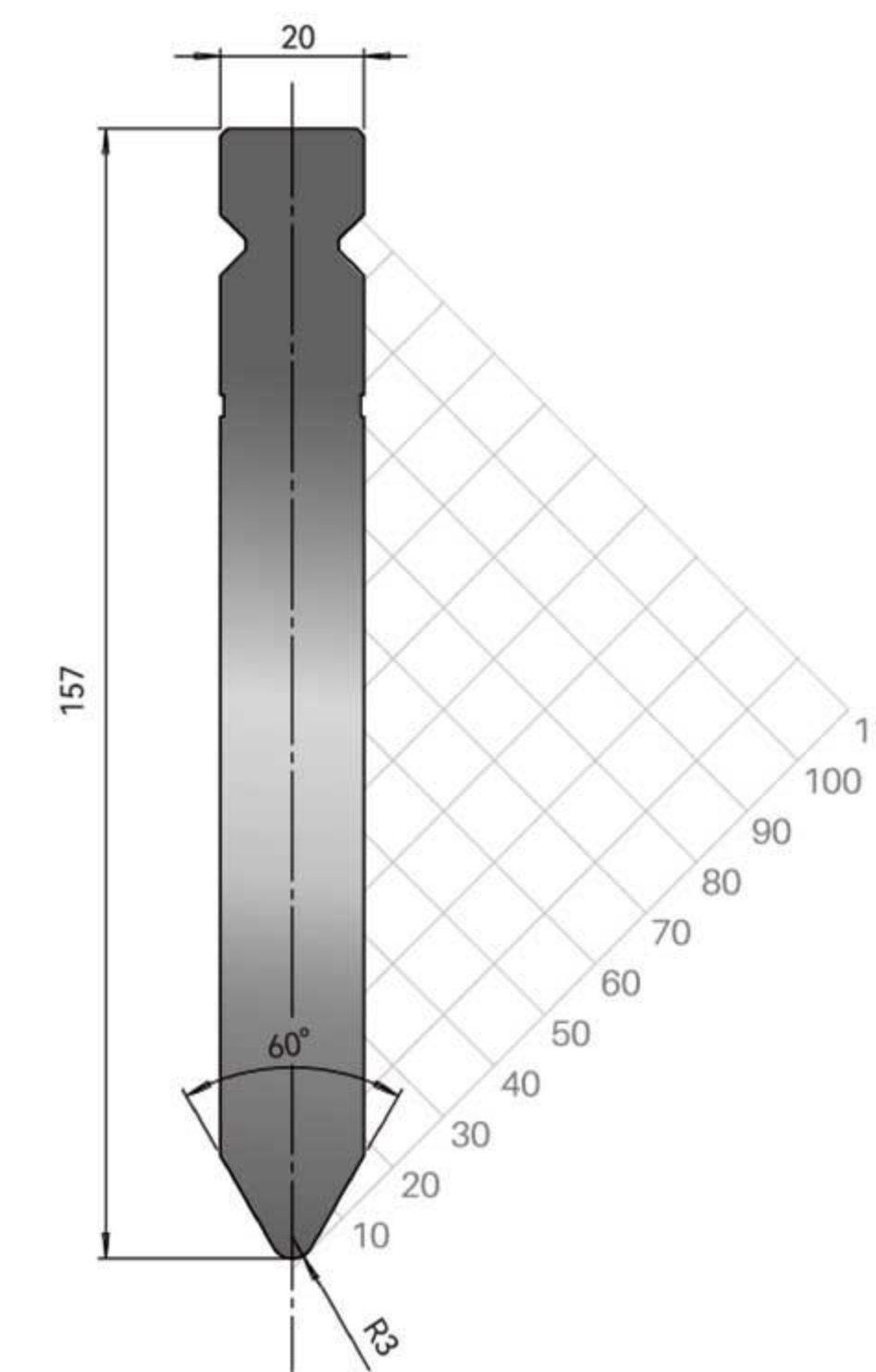

ZWP014

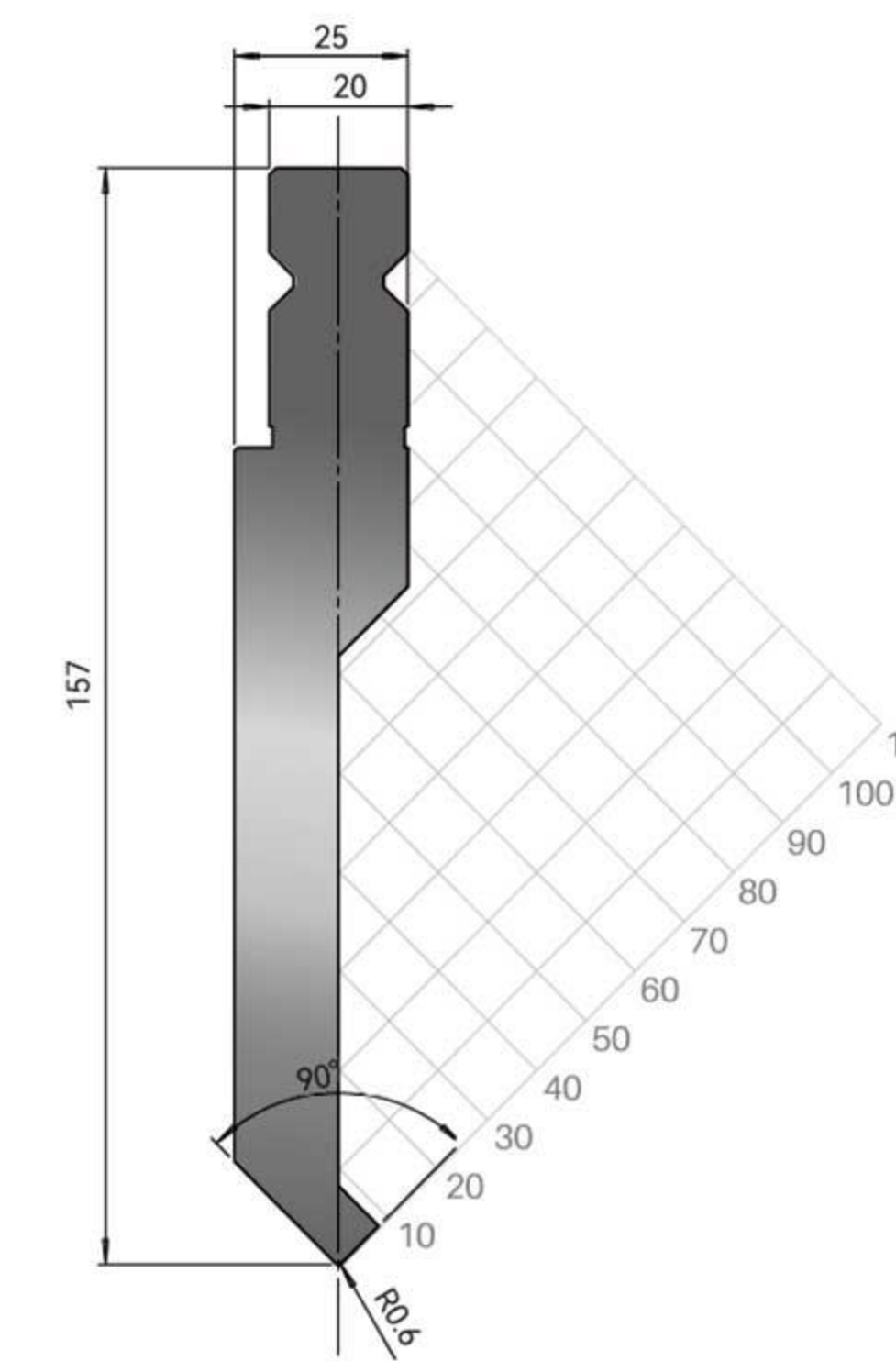

ZWP015

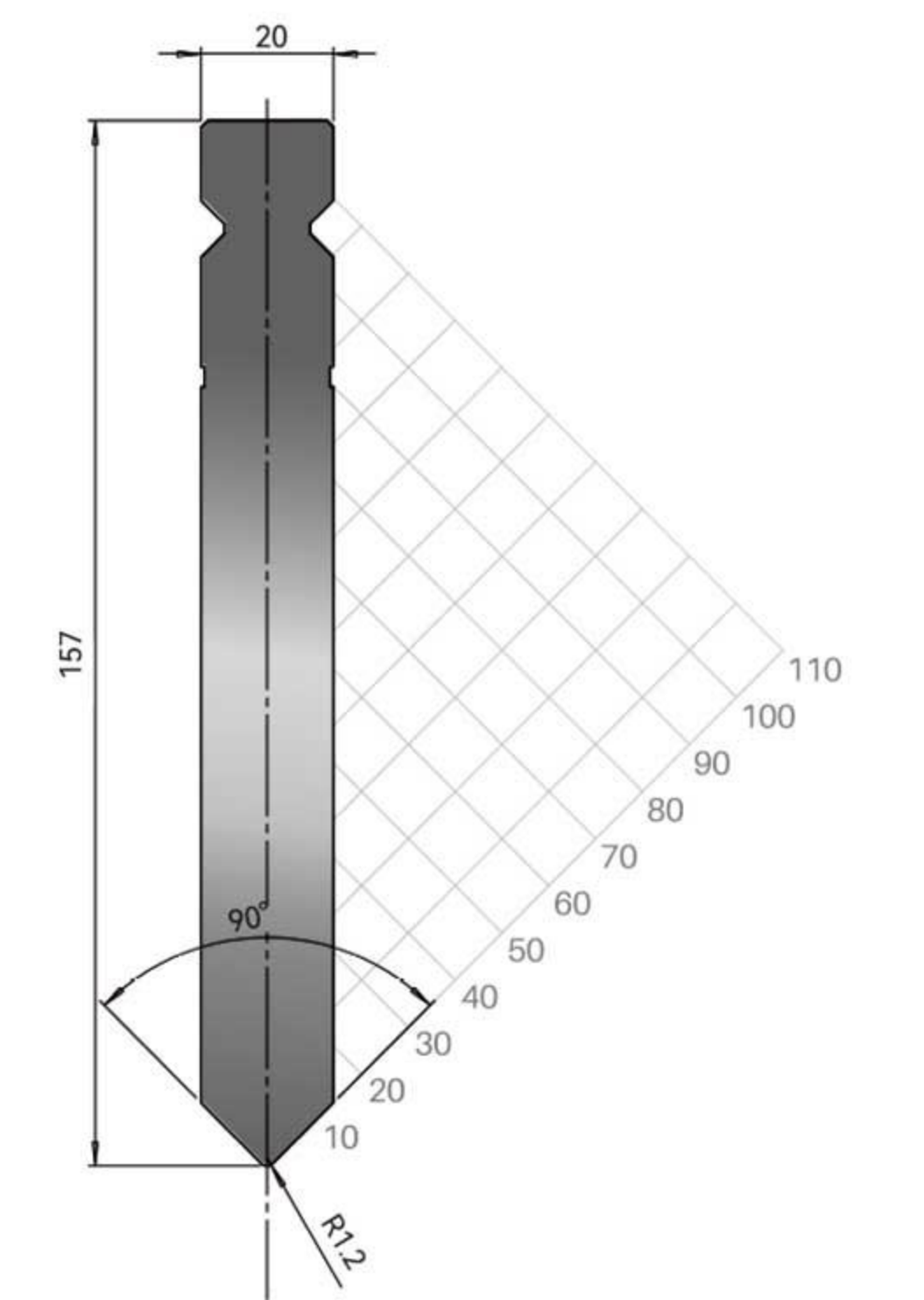

ZWP016

BENDMAX CAT.NO	WILA CAT.NO	Max Loading (t/m)	Weight (kg/m)
ZWP011	BIU-011	100	18.5
ZWP012	BIU-012	100	19
ZWP013	BIU-013	65	30
ZWP014	BIU-014	160	23.5
ZWP015	BIU-015	60	21.5
ZWP016	BIU-016	100	24



Punches-Height 200

PRESSBRAKE TOOLS-BENDMAX-WILASTYLE

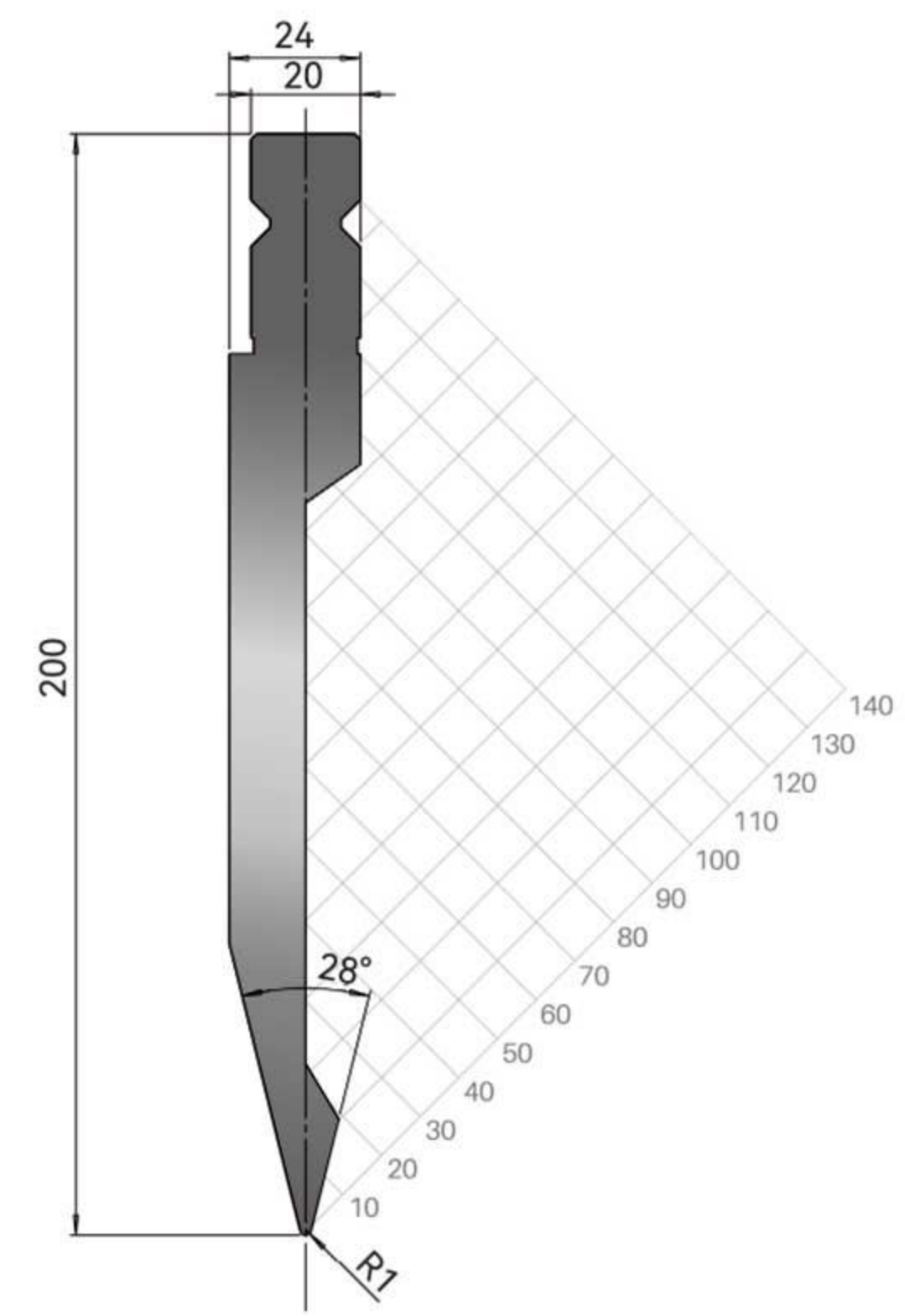

ZWP021

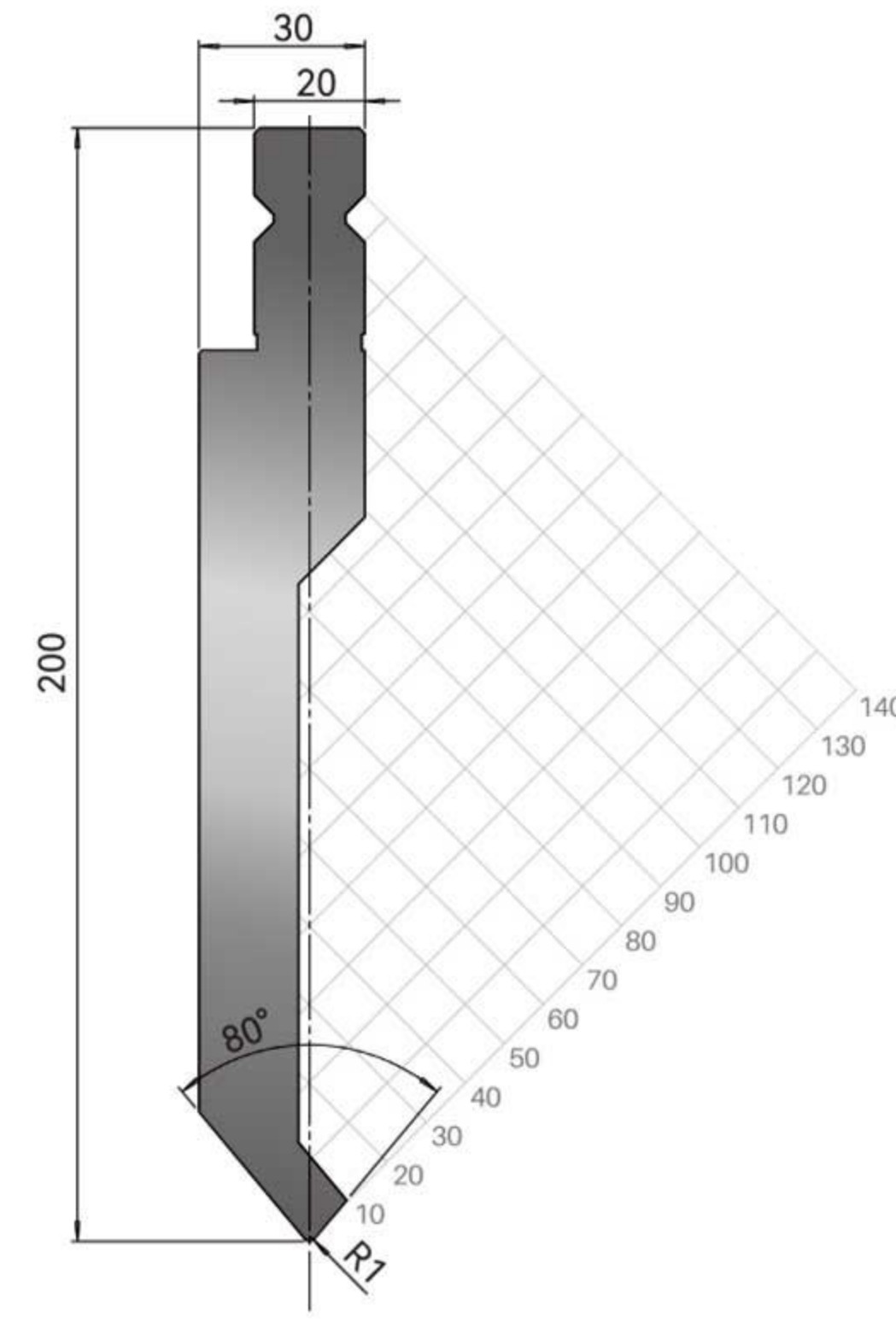

ZWP022

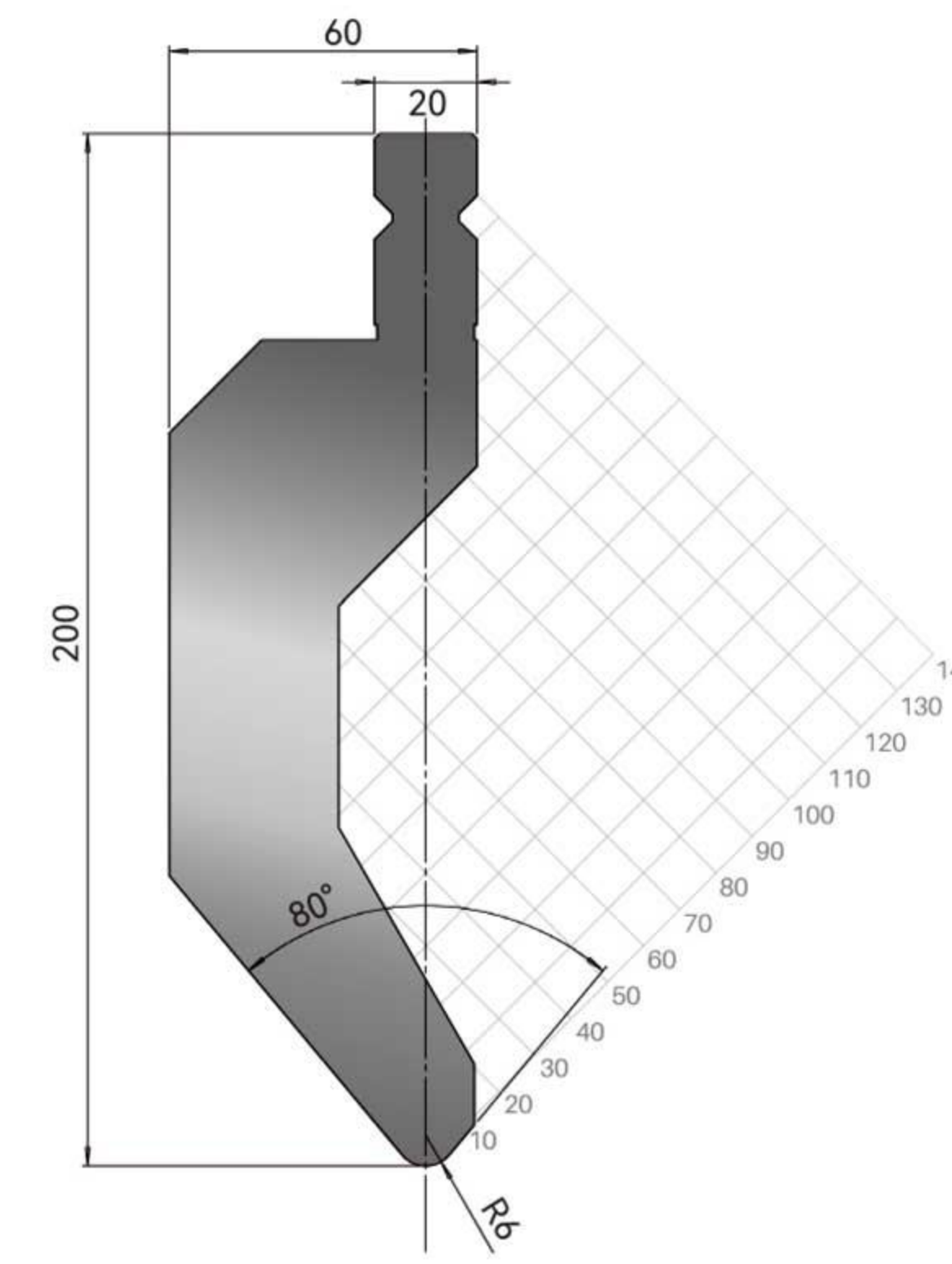

ZWP025

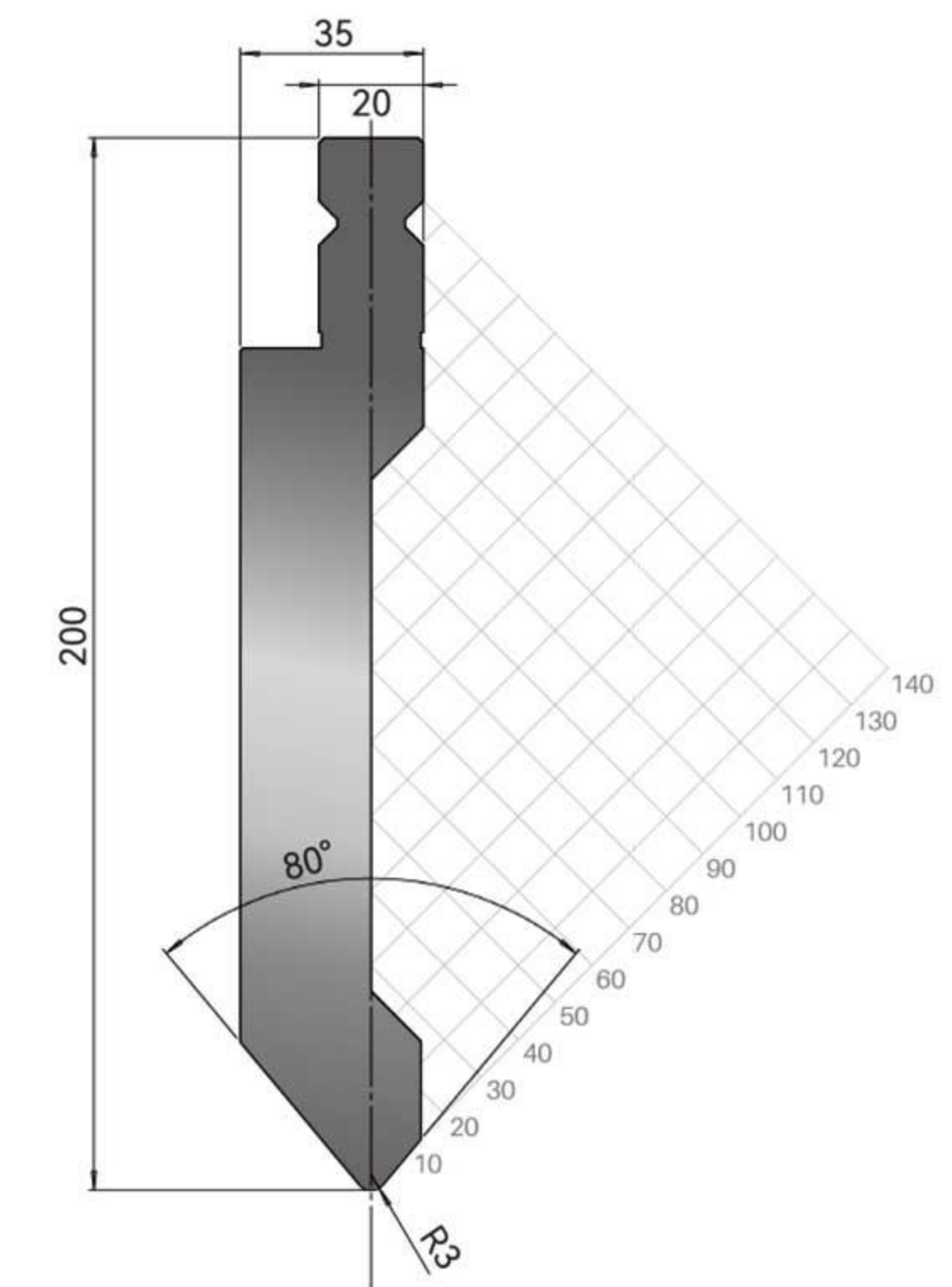

ZWP026

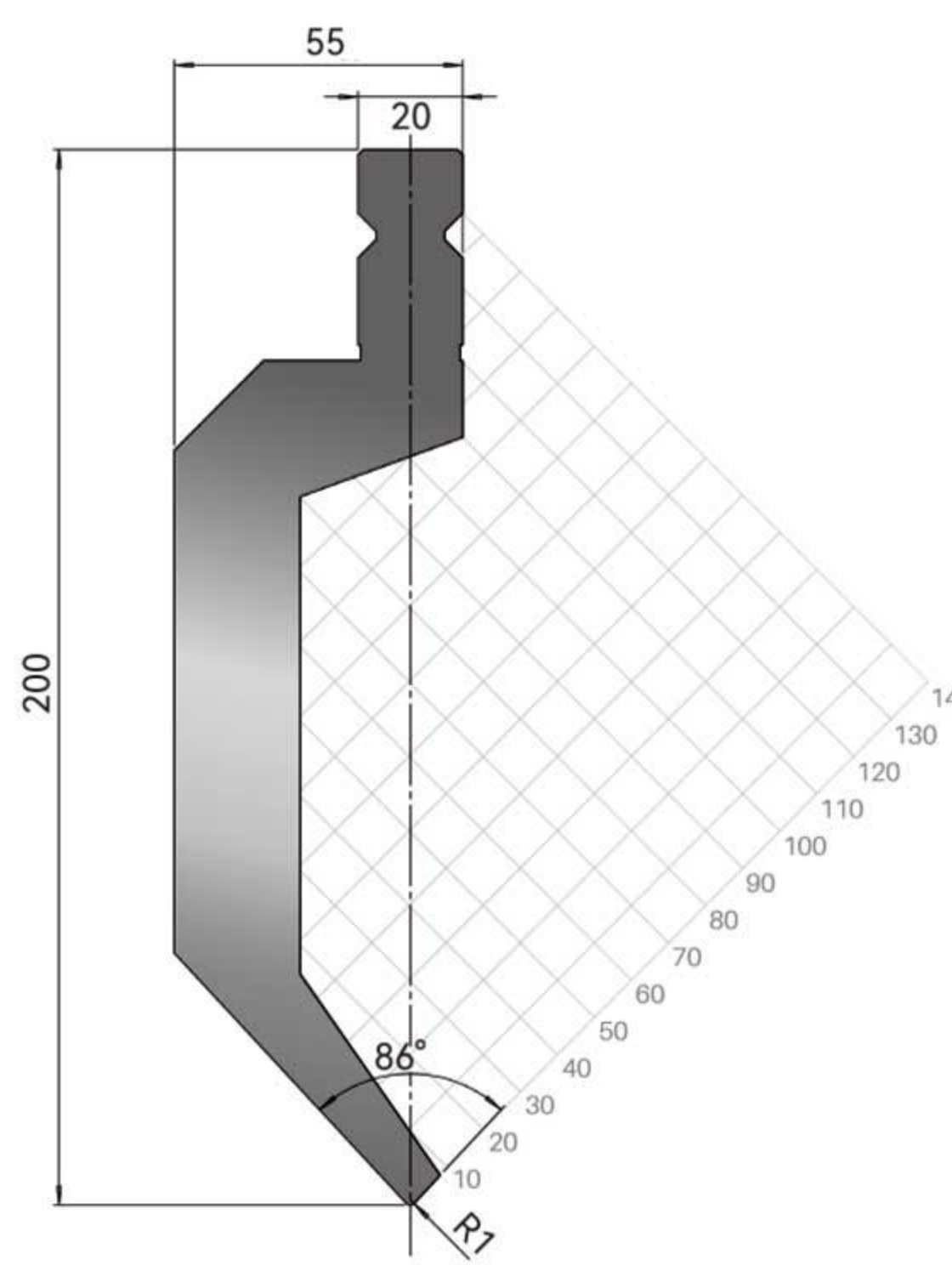

ZWP023

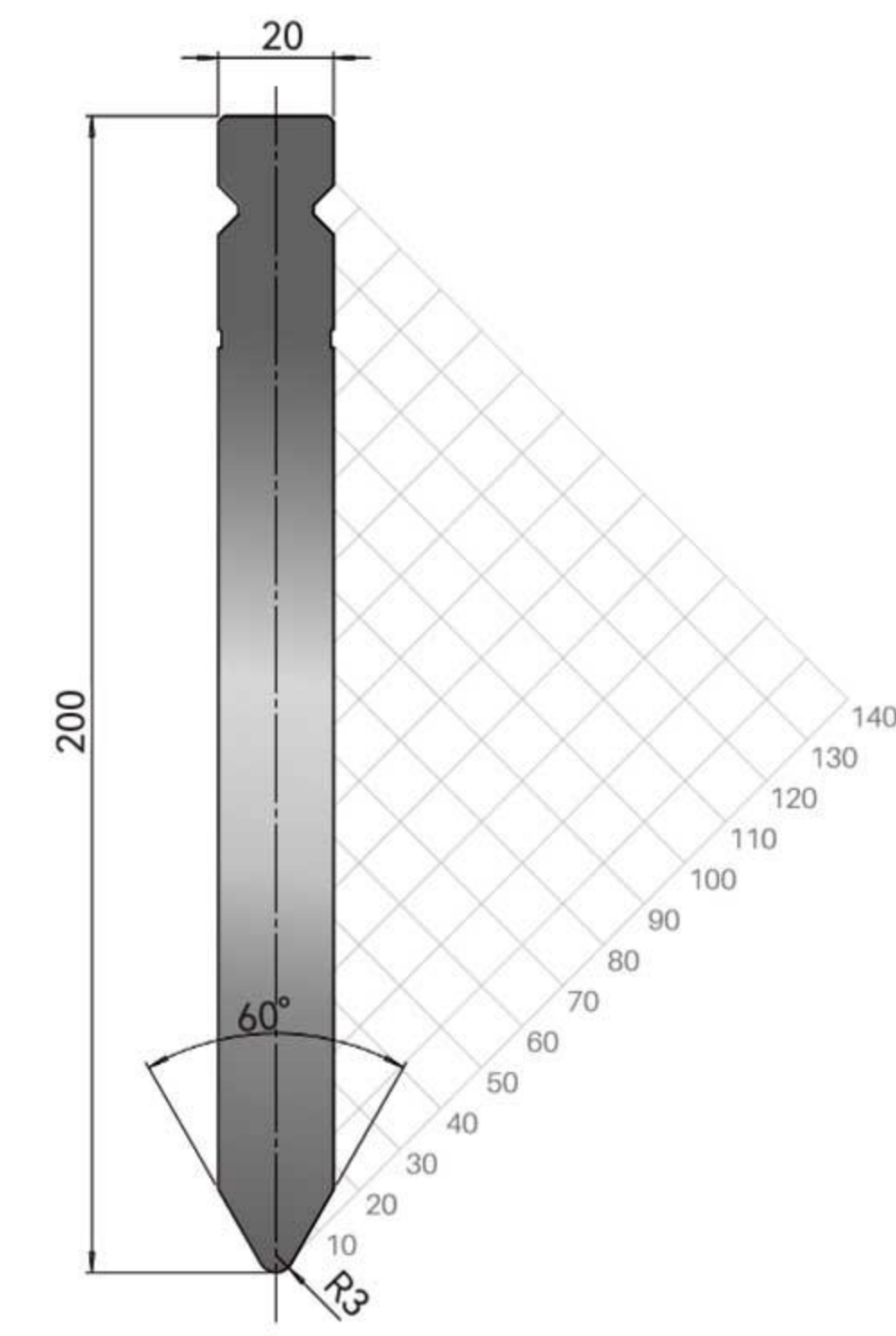

ZWP024

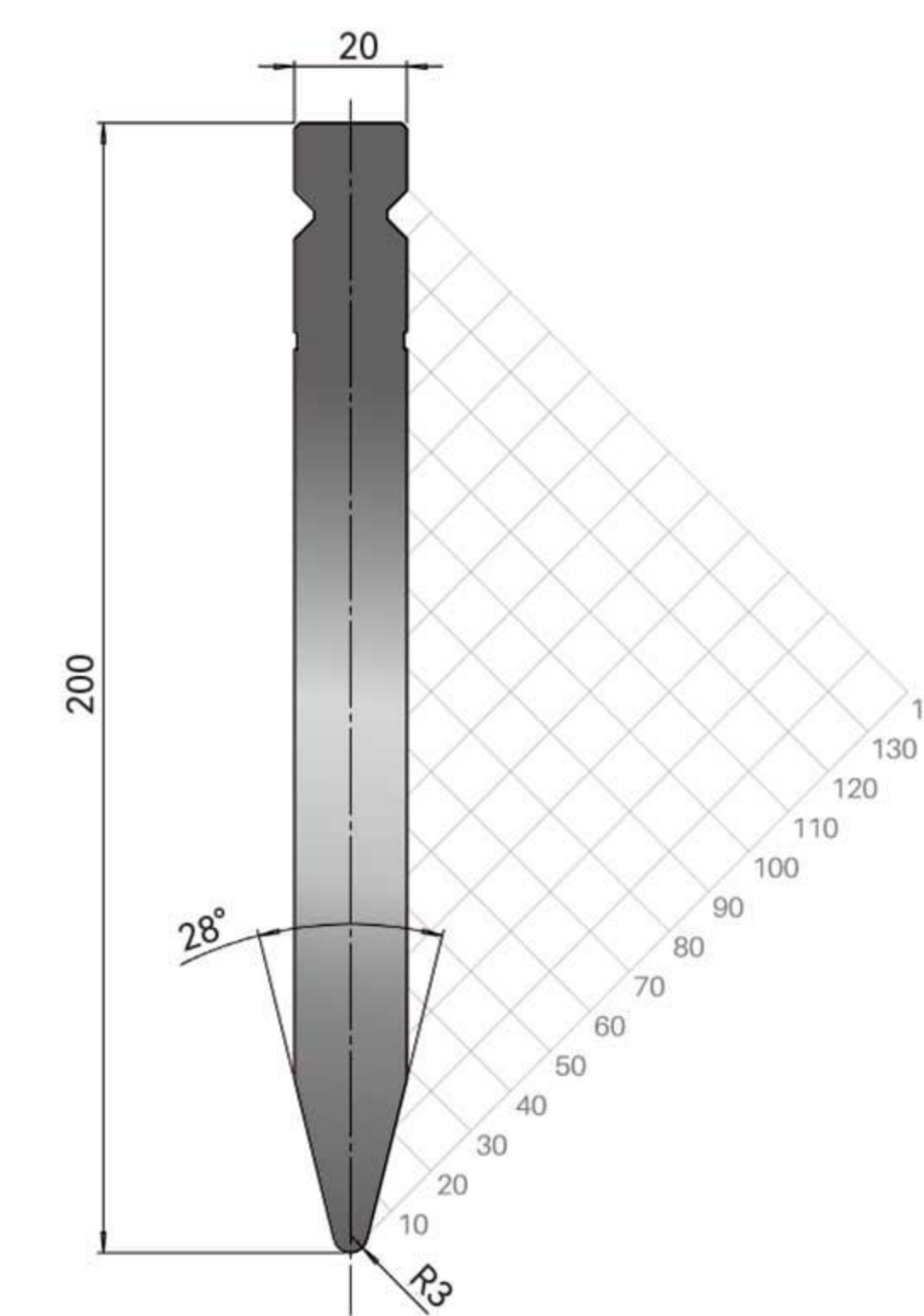

ZWP029

BENDMAX CAT.NO	WILA CAT.NO	Max Loading (t/m)	Weight (kg/m)
ZWP021	BIU-021	70	24
ZWP022	BIU-022	80	31.5
ZWP023	BIU-023	65	38
ZWP024	BIU-024	160	31



Punches-Height 200

PRESSBRAKE TOOLS-BENDMAX-WILASTYLE

BENDMAX CAT.NO	WILA CAT.NO	Max Loading (t/m)	Weight (kg/m)
ZWP025	BIU-025	130	54
ZWP026	BIU-026	140	38
ZWP029	BIU-029	160	30.5



Punches-Height 237

PRESSBRAKE TOOLS-BENDMAX-WILASTYLE



Punches-Height 237

PRESSBRAKE TOOLS-BENDMAX-WILASTYLE

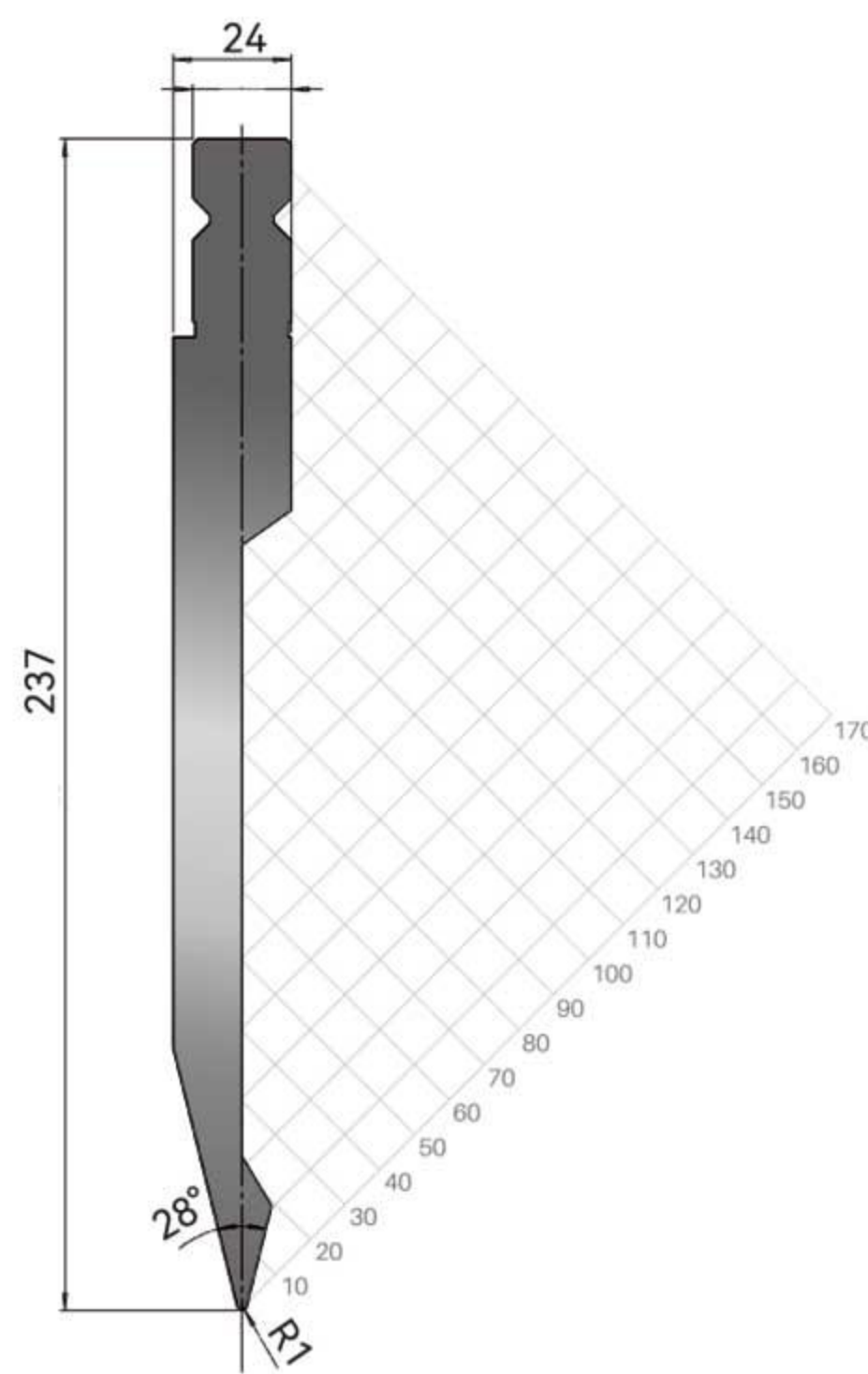

ZWP031

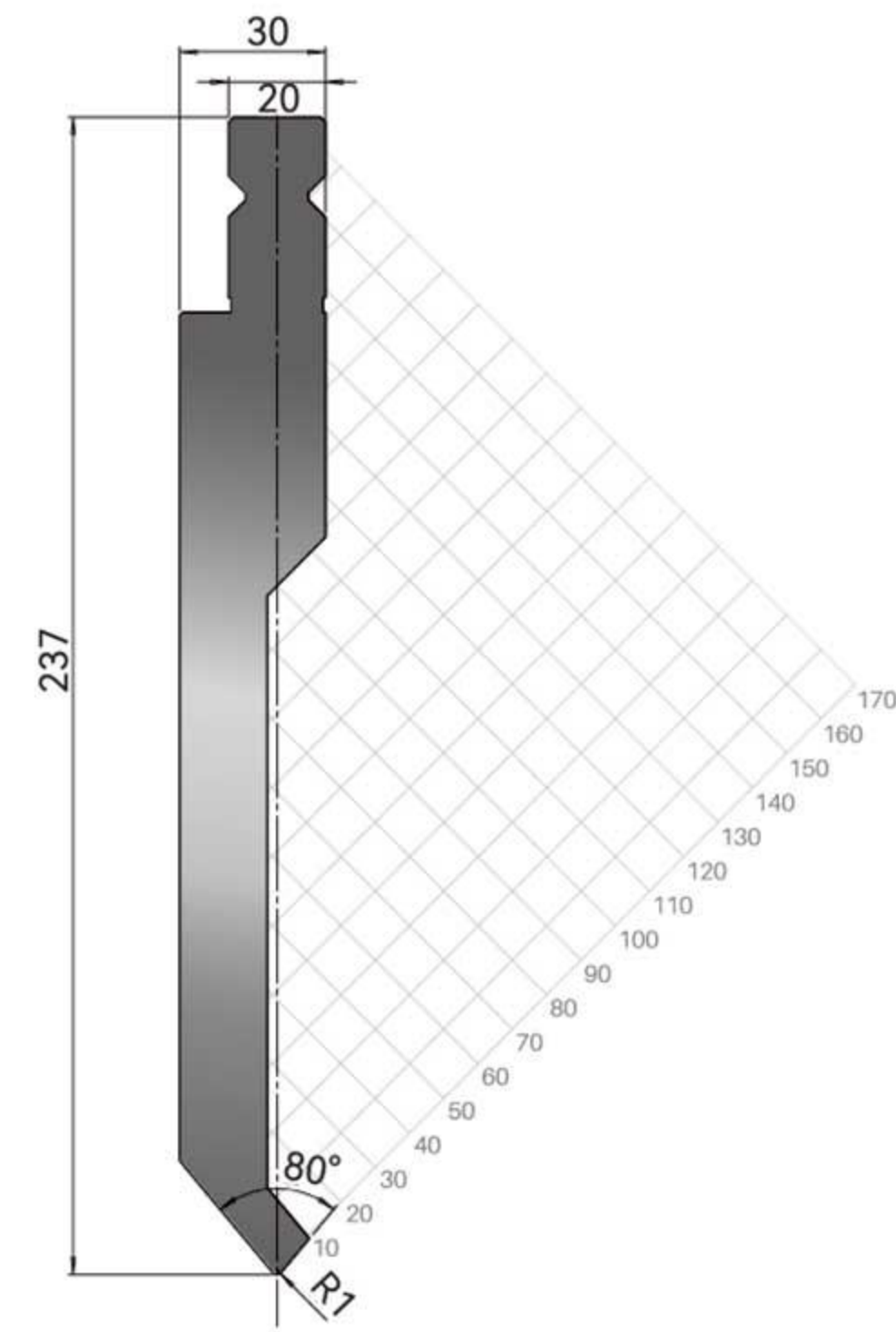

ZWP032

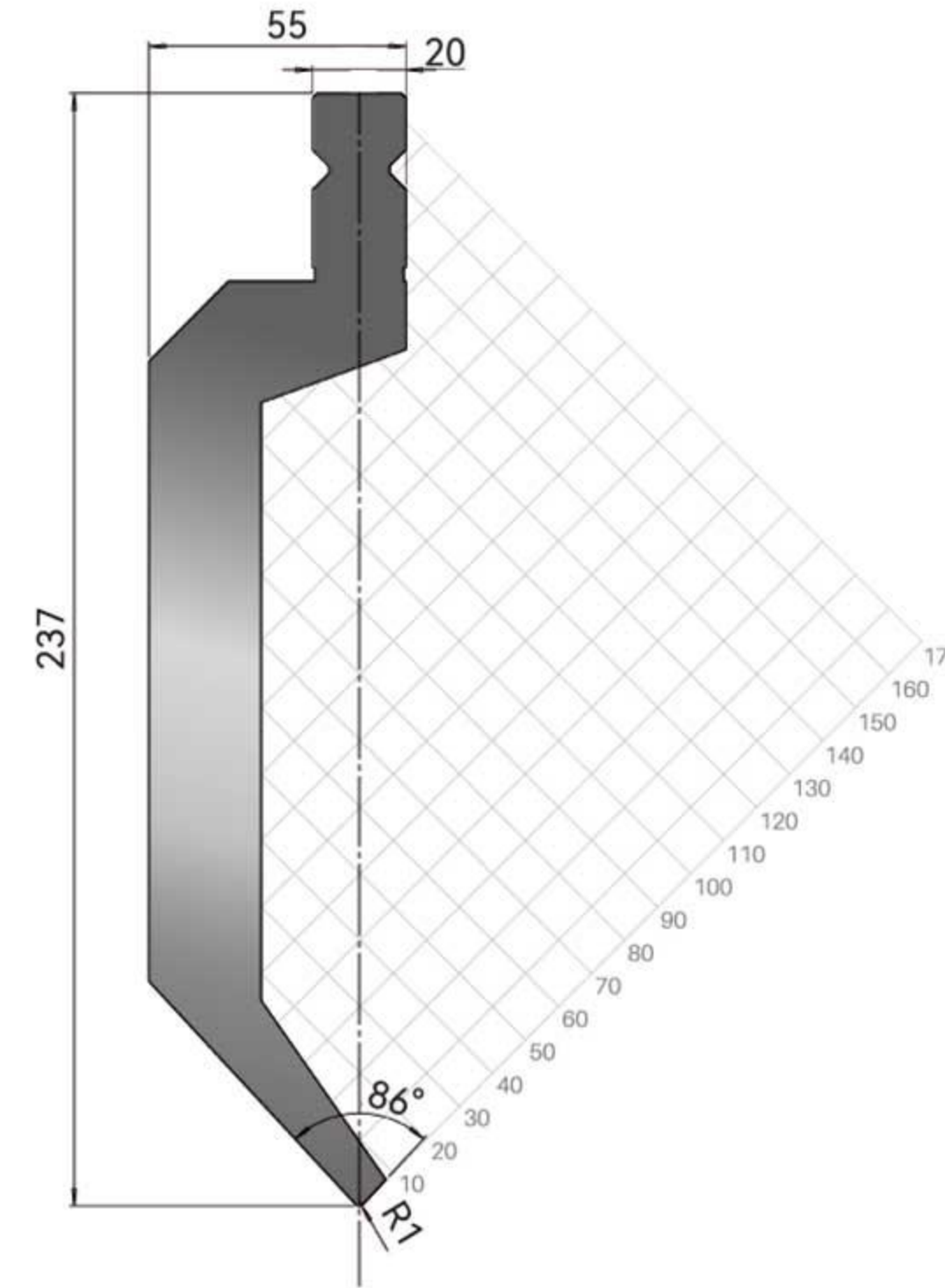

ZWP033

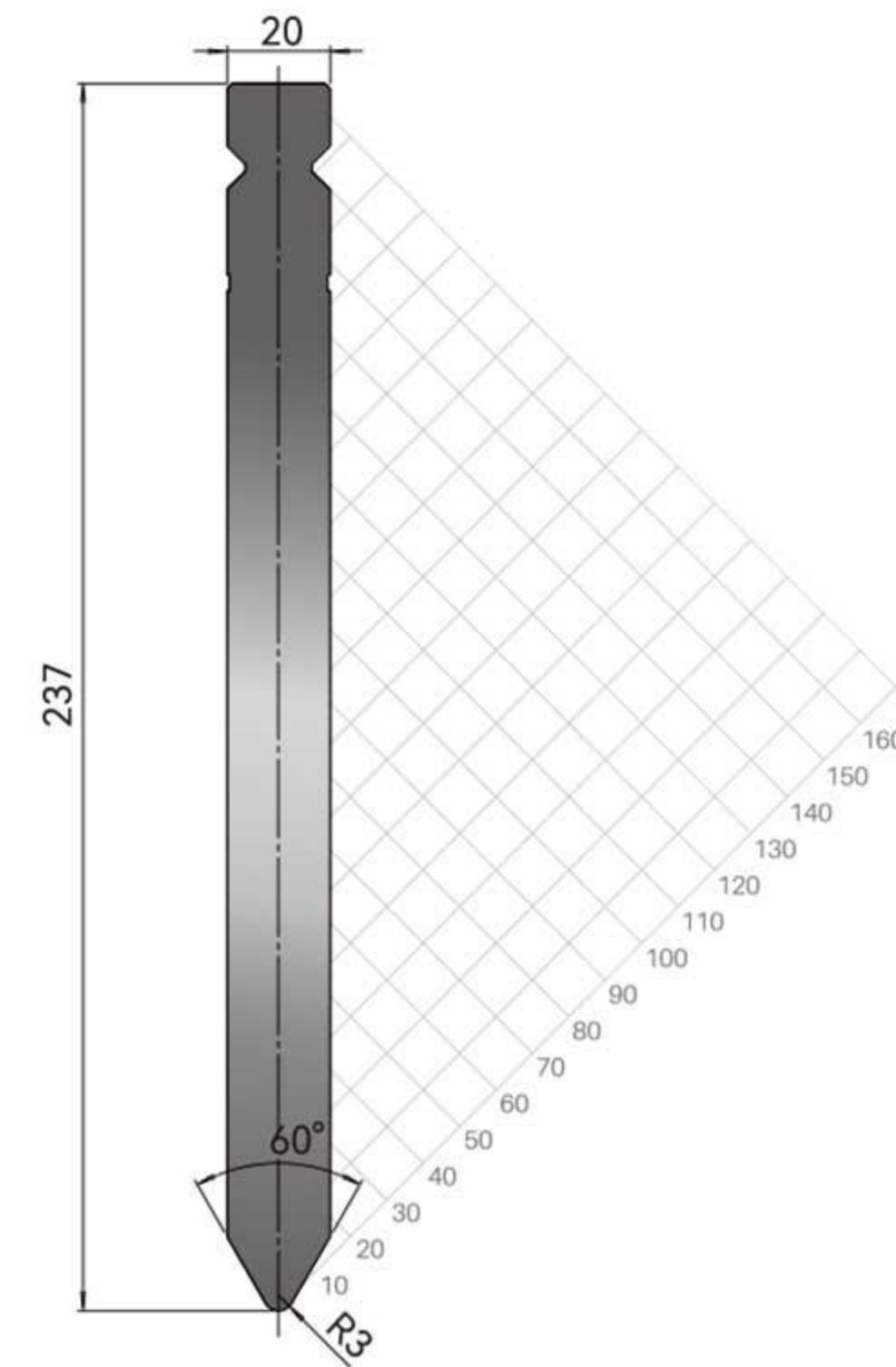

ZWP034

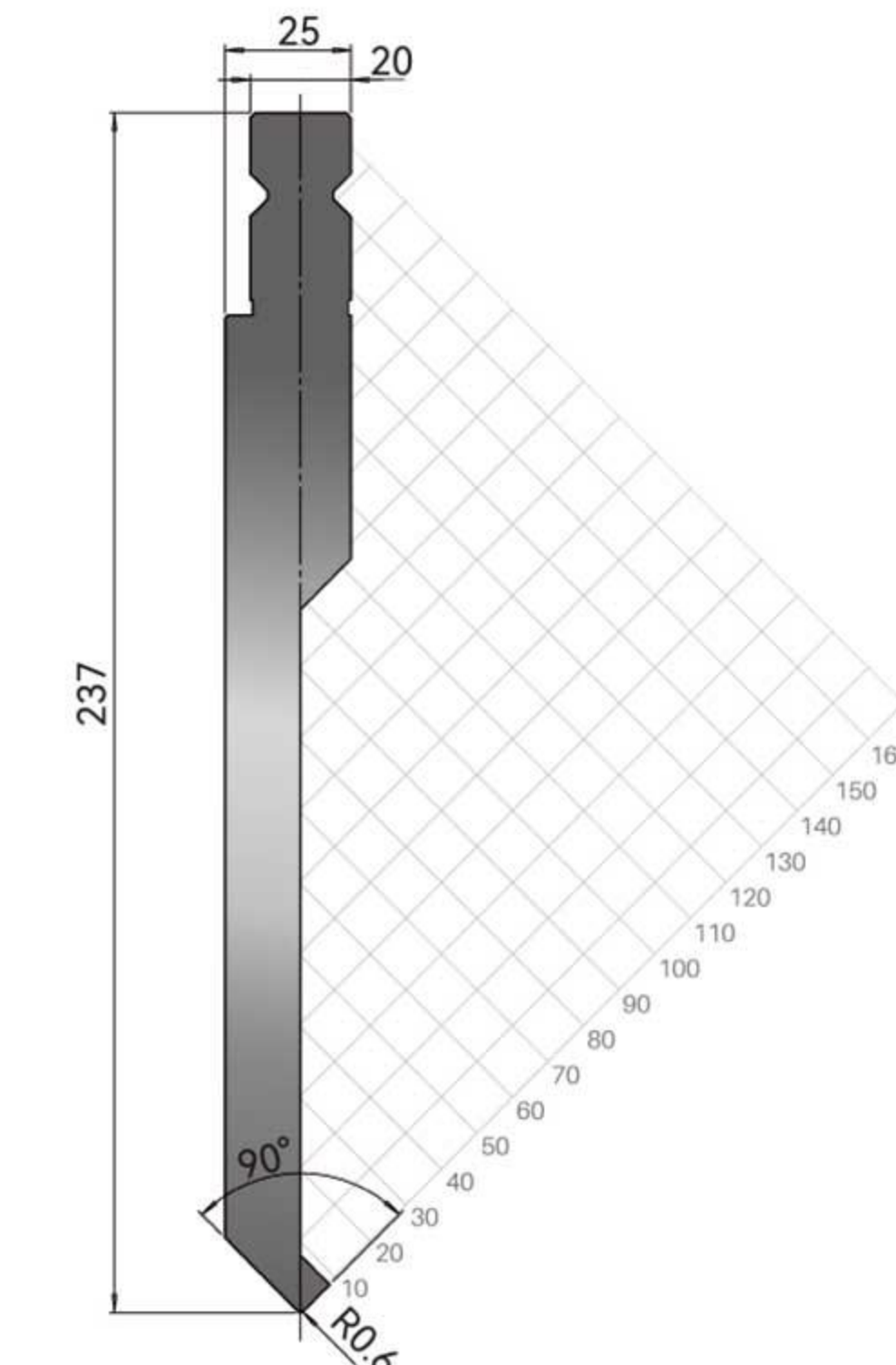

ZWP035

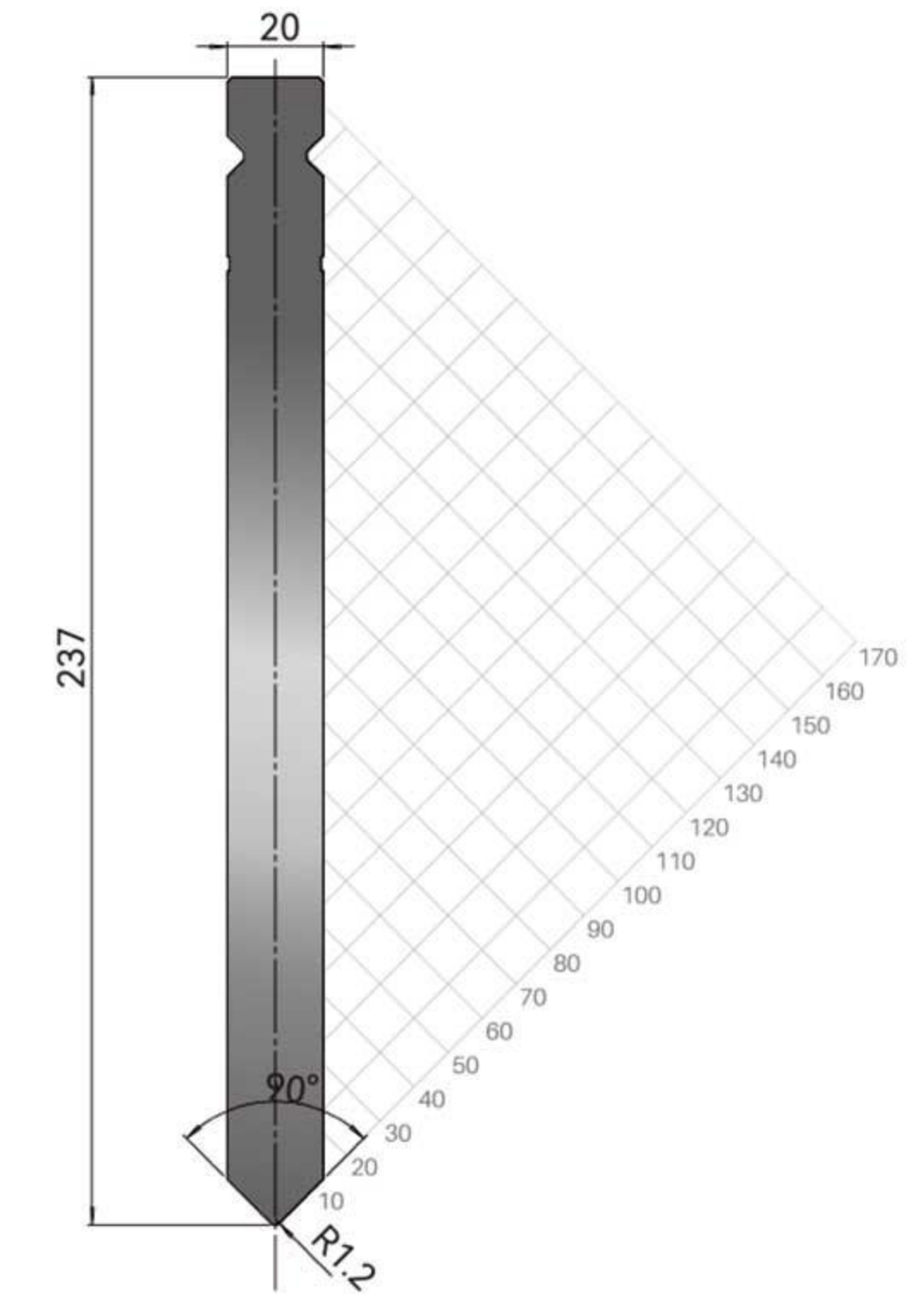

ZWP036

BENDMAX CAT.NO	WILA CAT.NO	Max Loading (t/m)	Weight (kg/m)
ZWP031	BIU-031	60	29
ZWP032	BIU-032	80	38.5
ZWP033	BIU-033	50	45

BENDMAX CAT.NO	WILA CAT.NO	Max Loading (t/m)	Weight (kg/m)
ZWP034	BIU-034	160	36.5
ZWP035	BIU-035	60	33.5
ZWP036	BIU-036	100	37

Dies Information

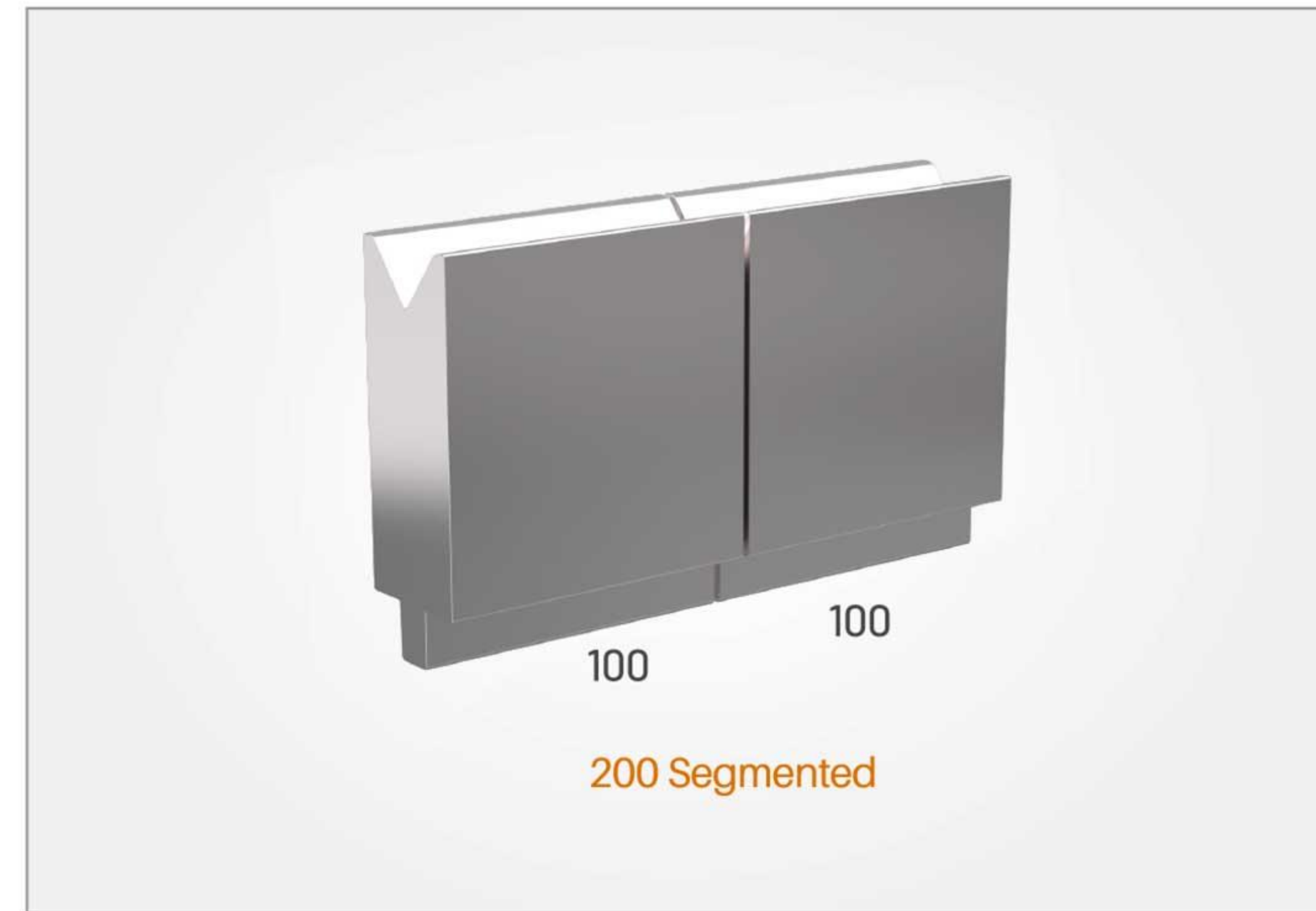

Die V=6mm

PRESSBRAKE TOOLS-BENDMAX-WILASTYLE

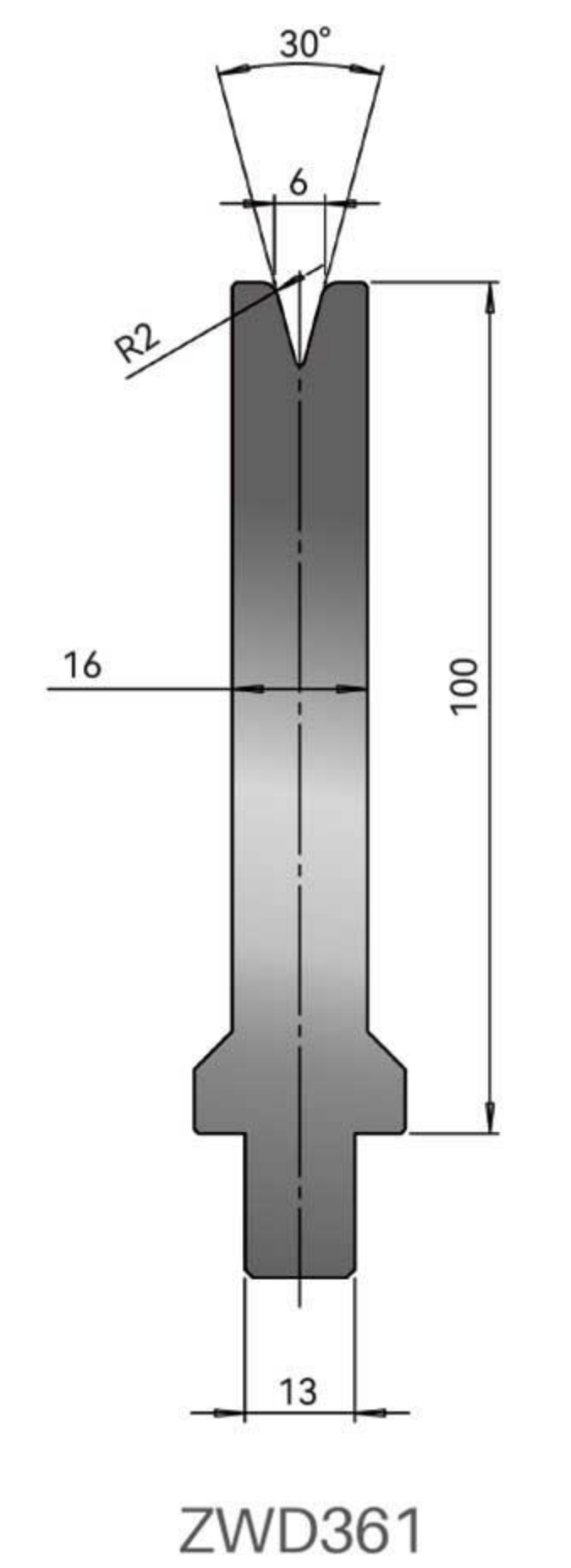
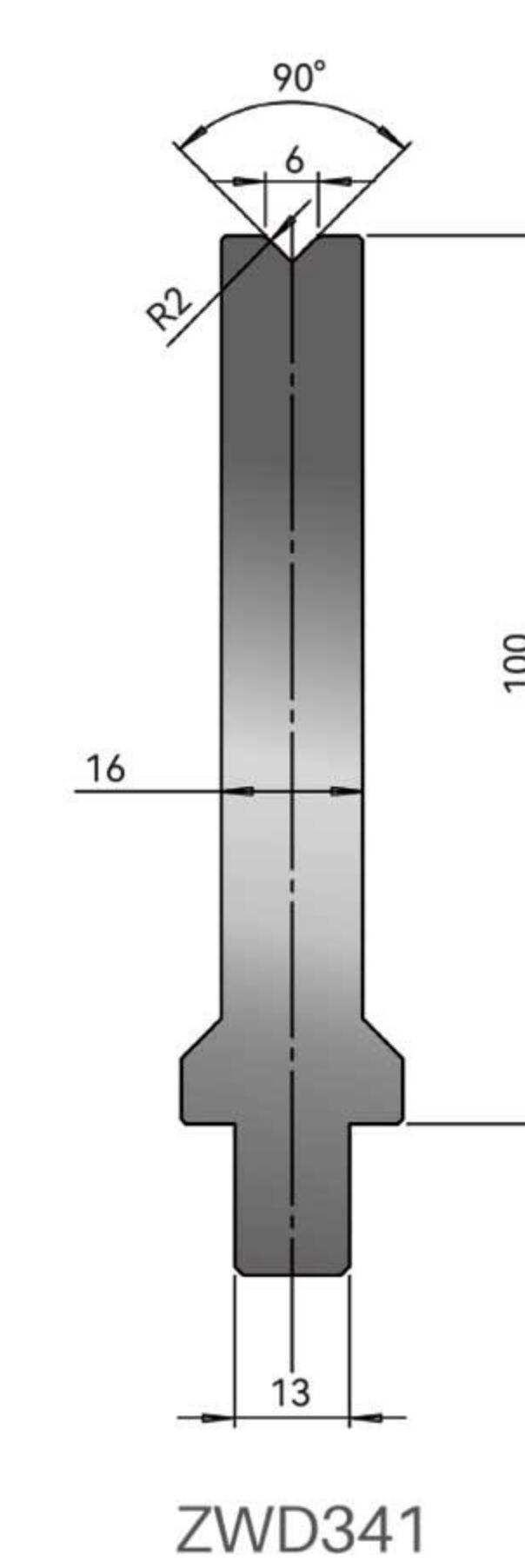
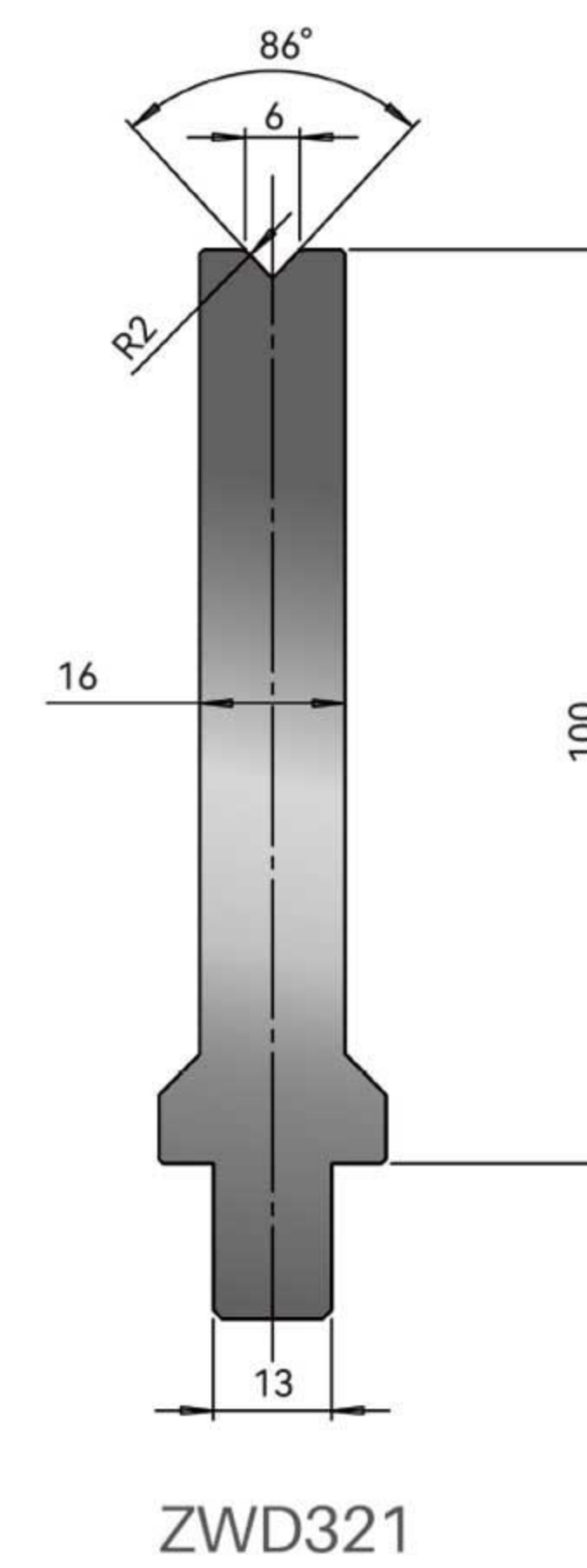
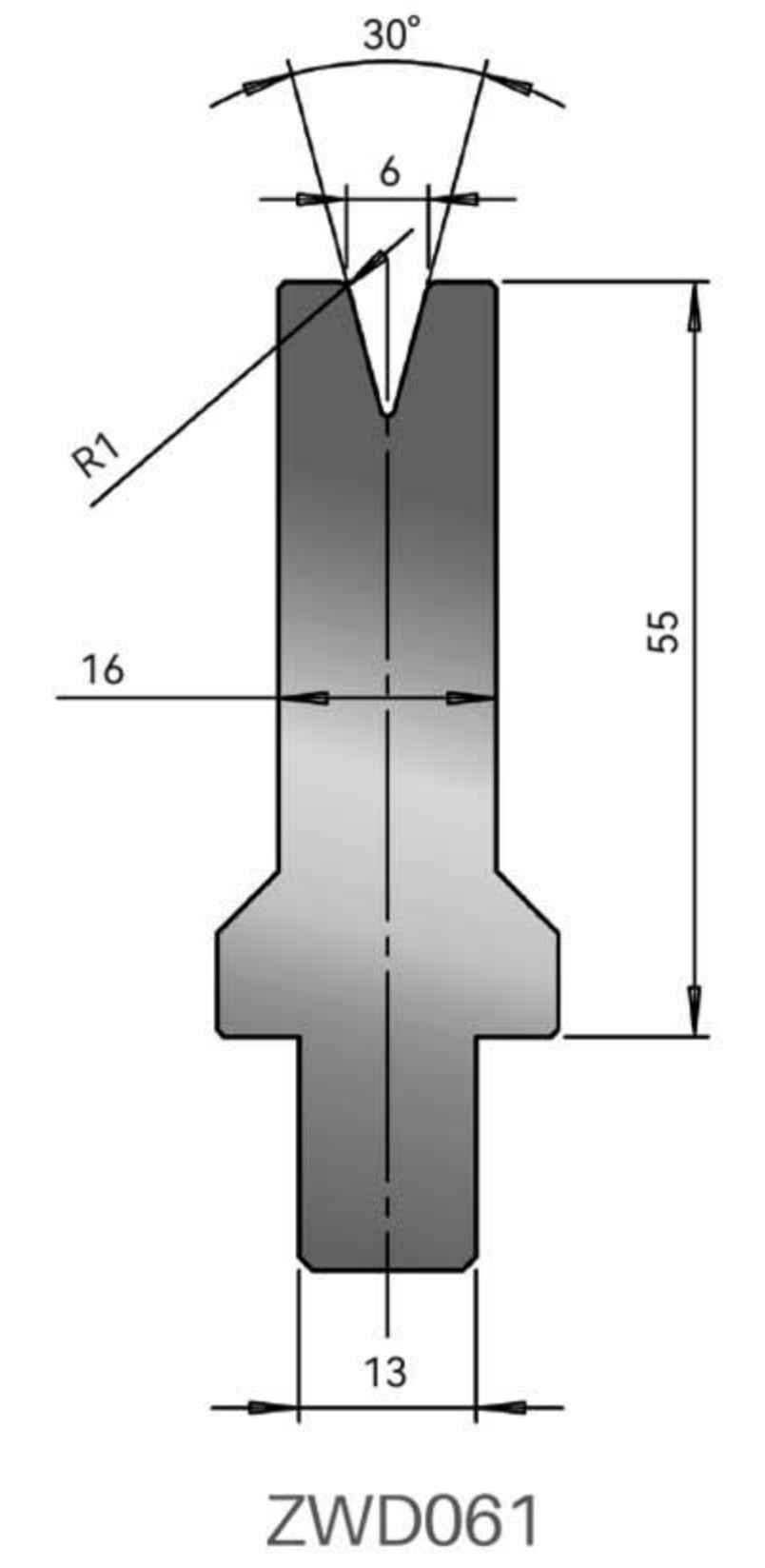
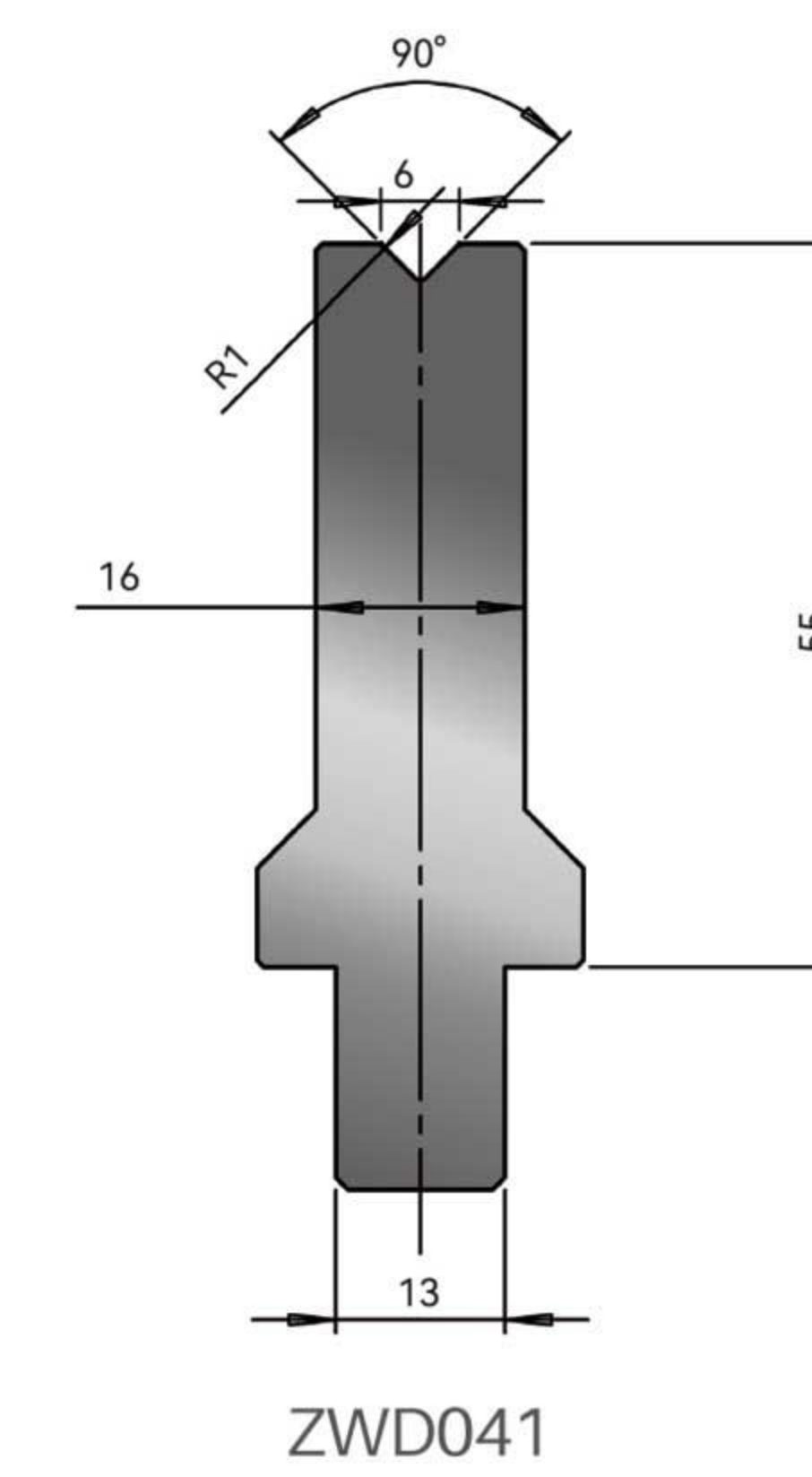
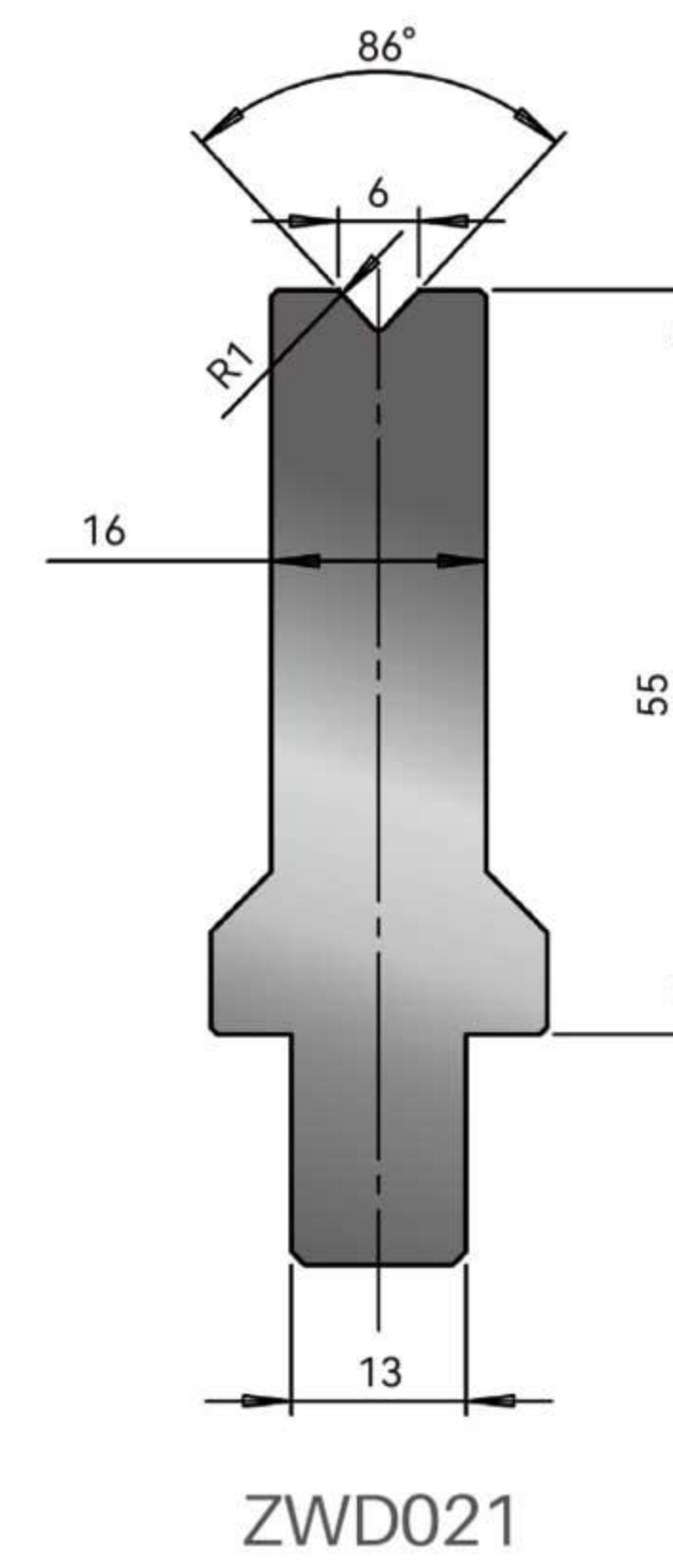

BENDMAX CAT.NO	WILA CAT.NO	Max Loading (t/m)	Weight (kg/m)
ZWD021	OZU-021	120	9.5
ZWD041	OZU-041	120	9.5
ZWD061	OZU-061	80	9.5
ZWD321	OZU-321	120	15
ZWD341	OZU-341	120	15
ZWD361	OZU-361	80	15



Die V=8mm

PRESSBRAKE TOOLS-BENDMAX-WILASTYLE

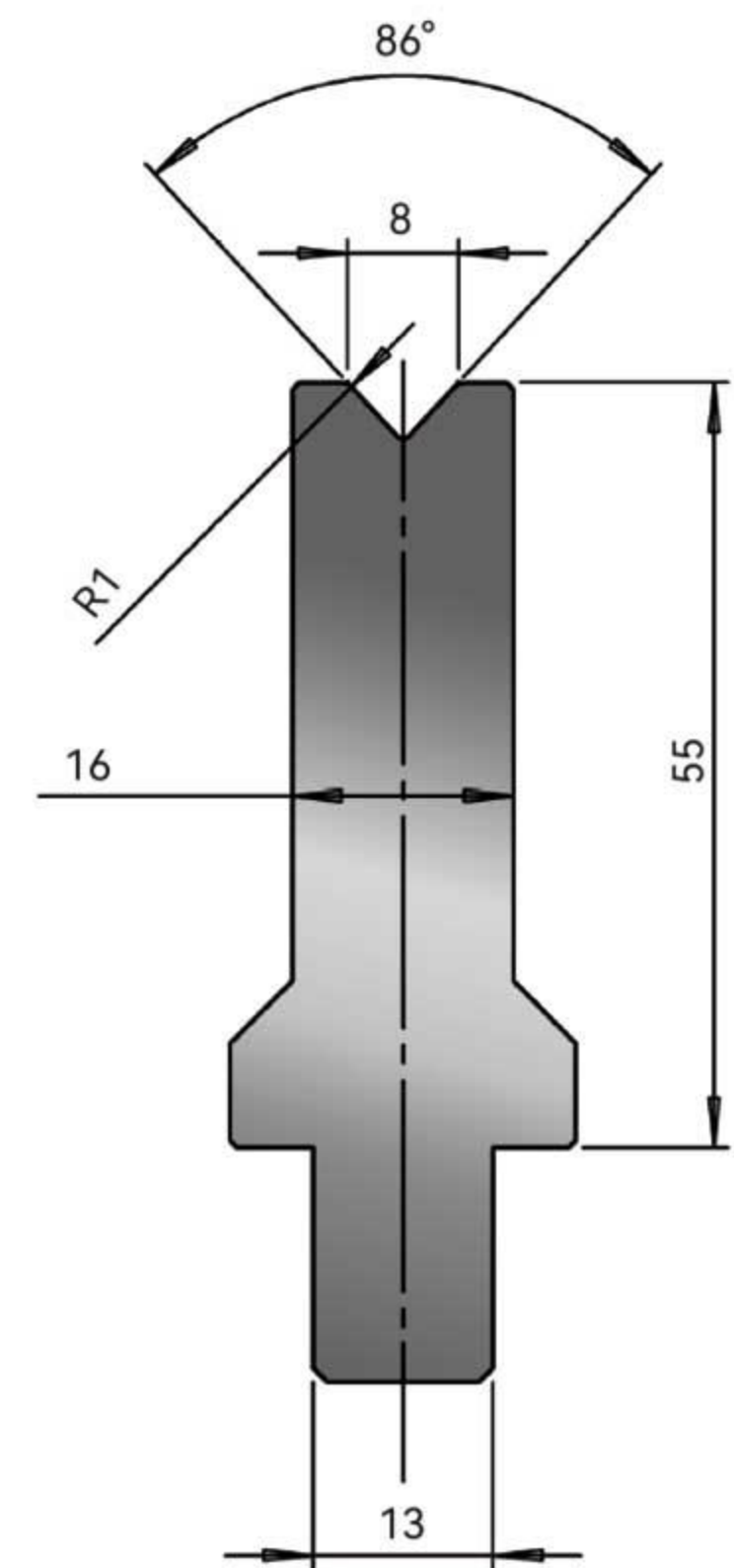

ZWD010

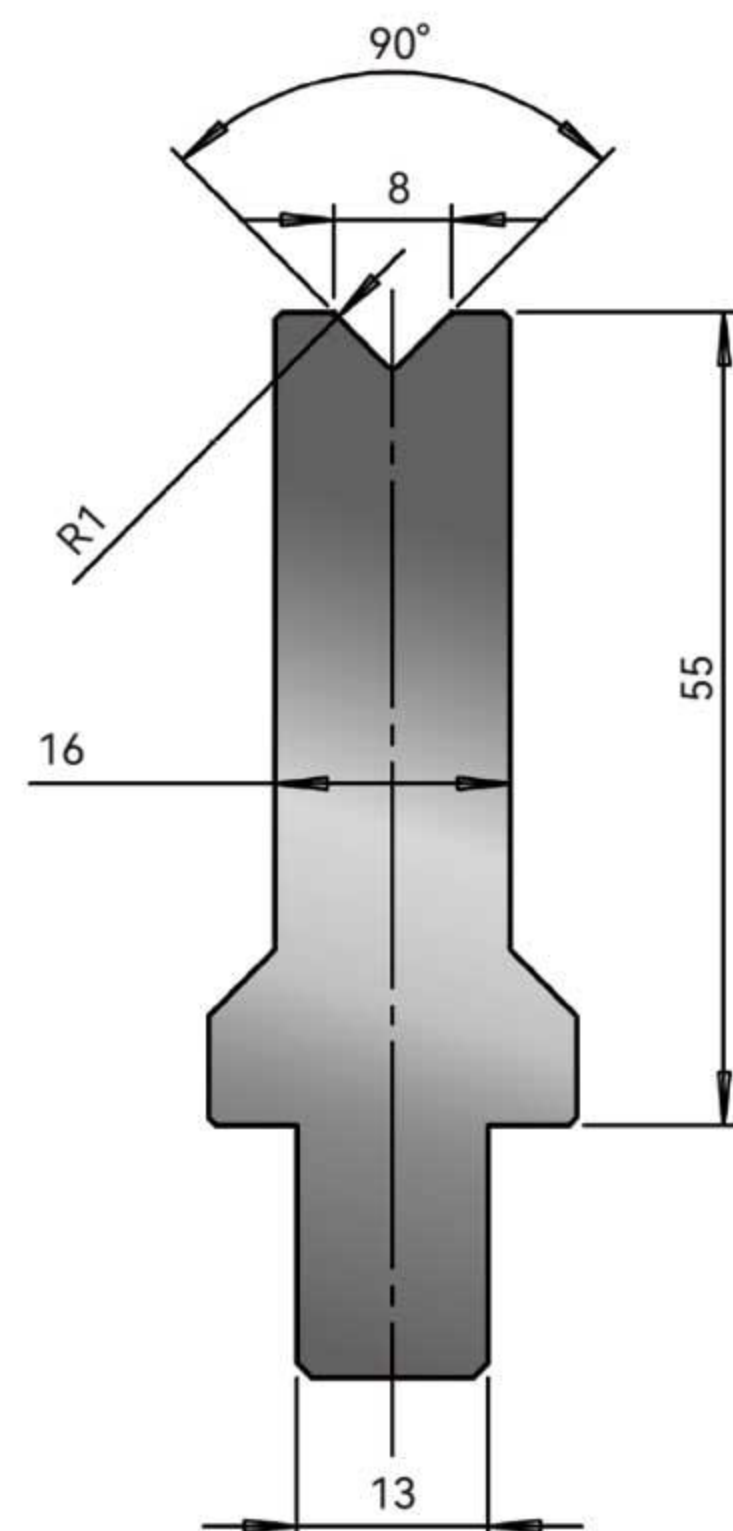

ZWD042

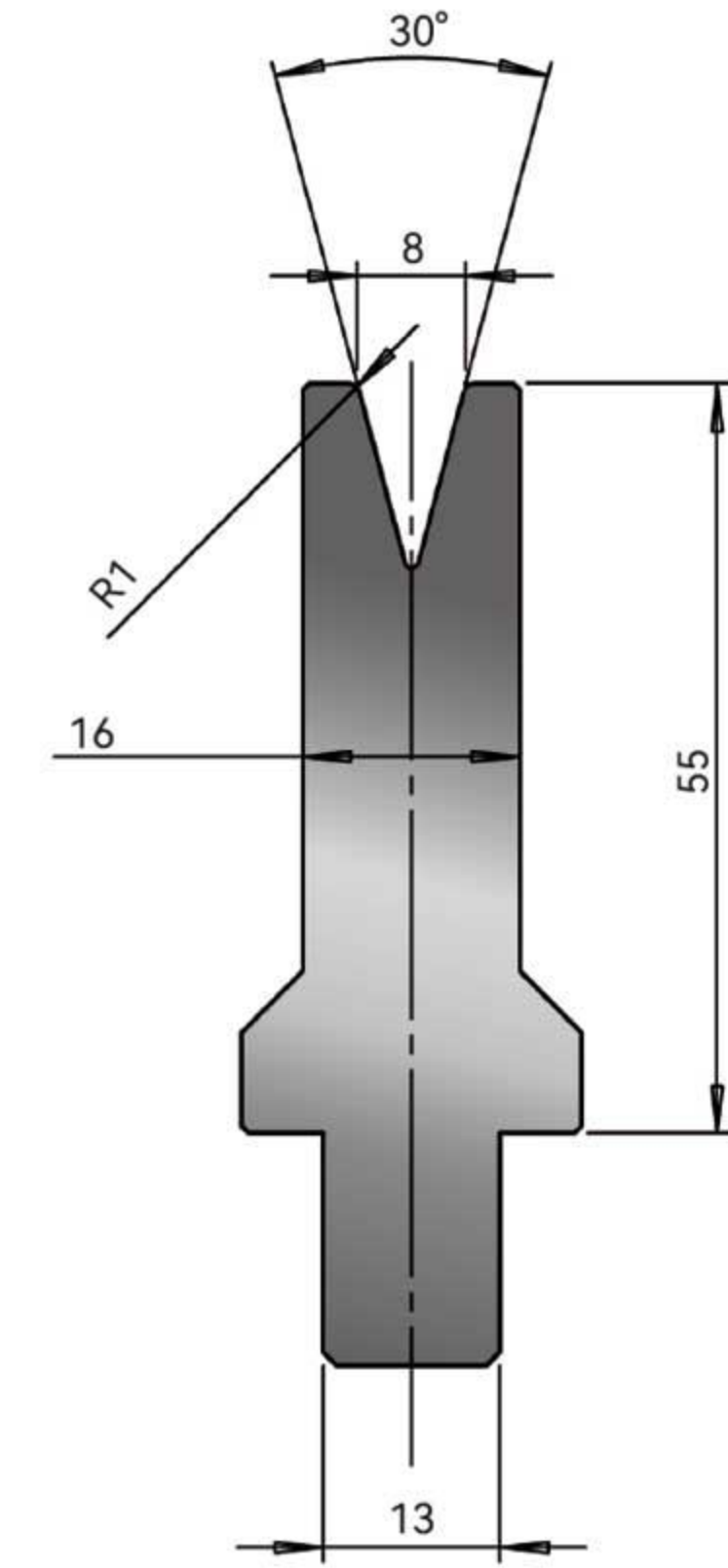

ZWD051



Die V=10mm

PRESSBRAKE TOOLS-BENDMAX-WILASTYLE

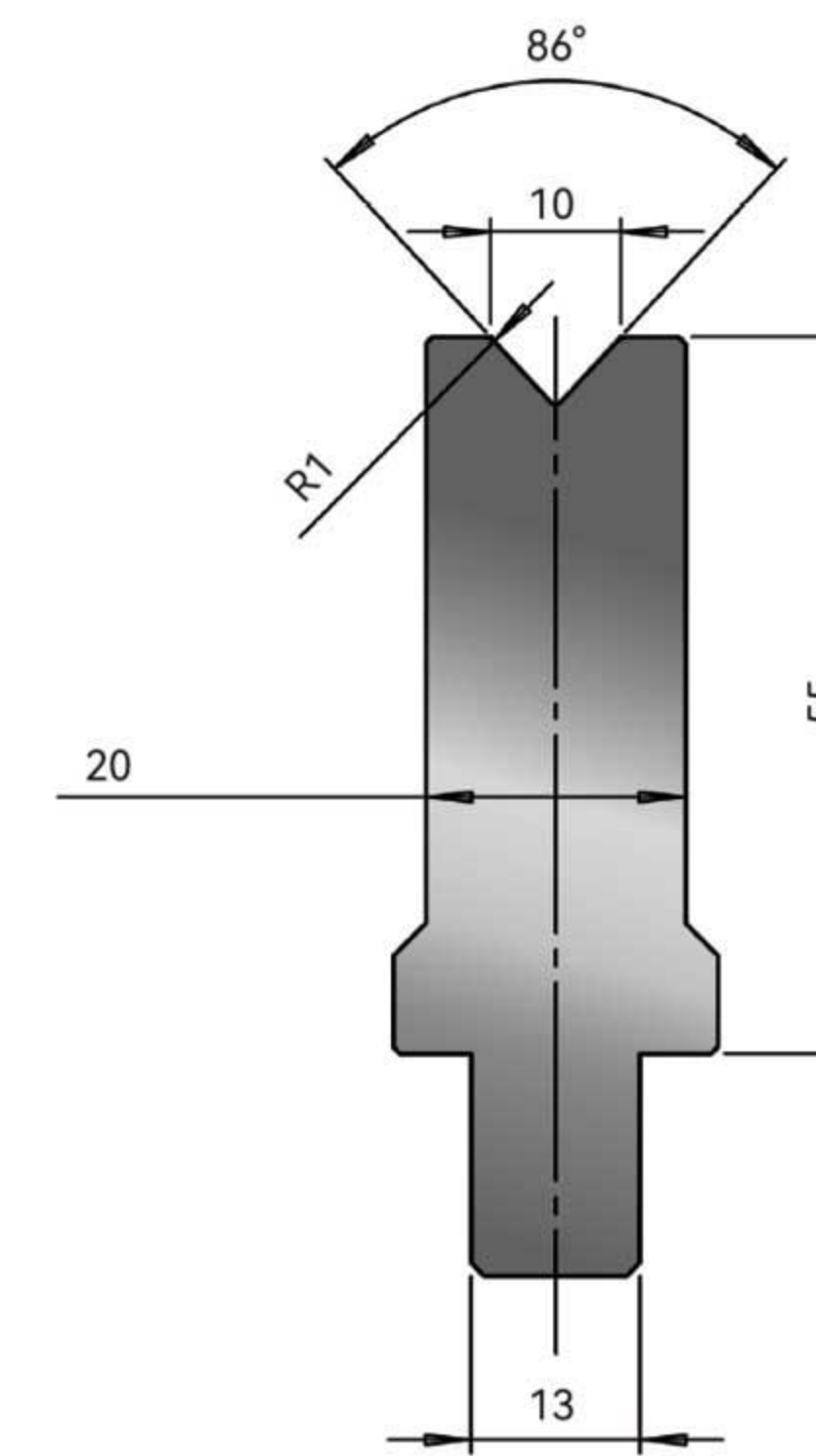

ZWD022

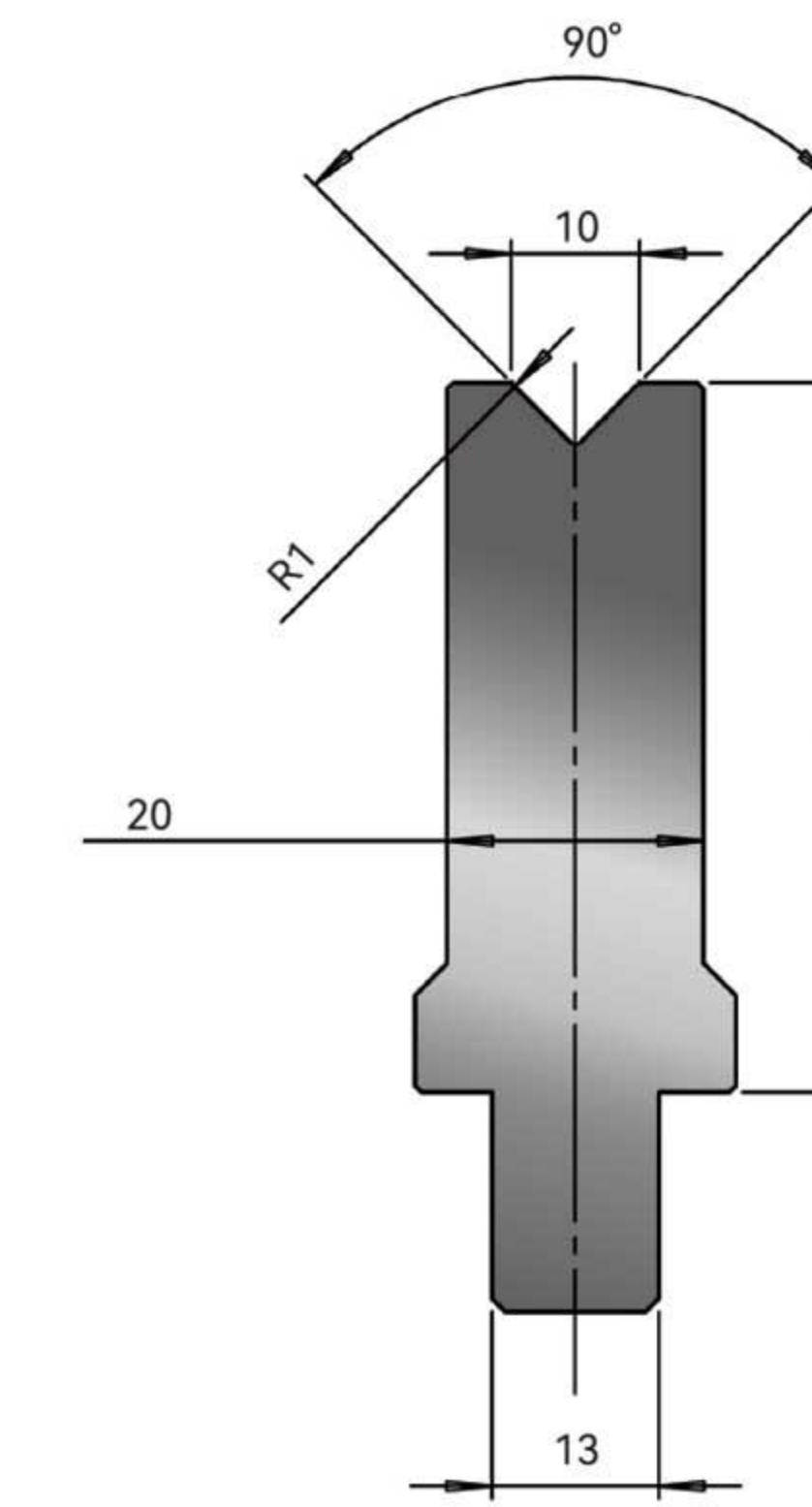

ZWD043

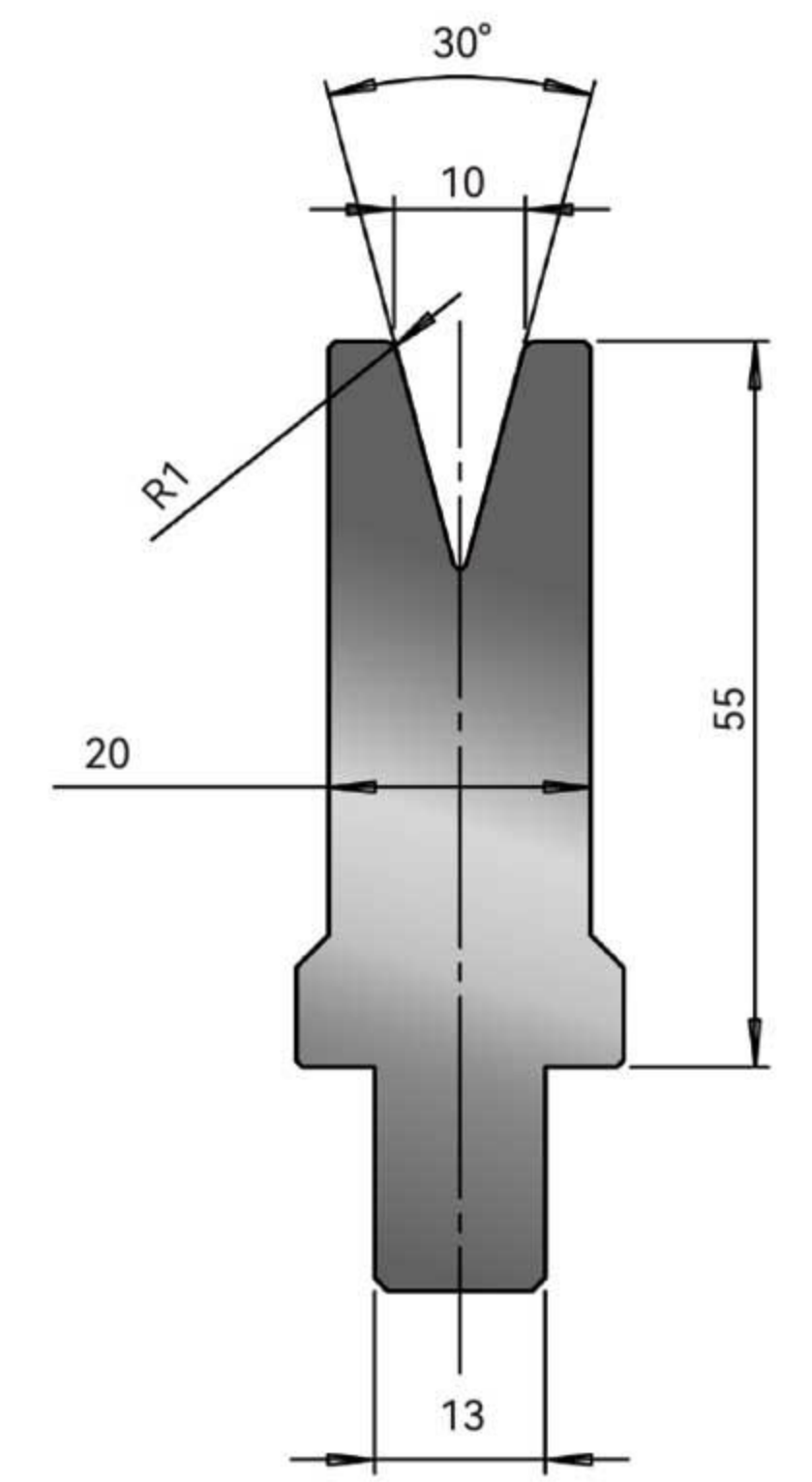

ZWD062

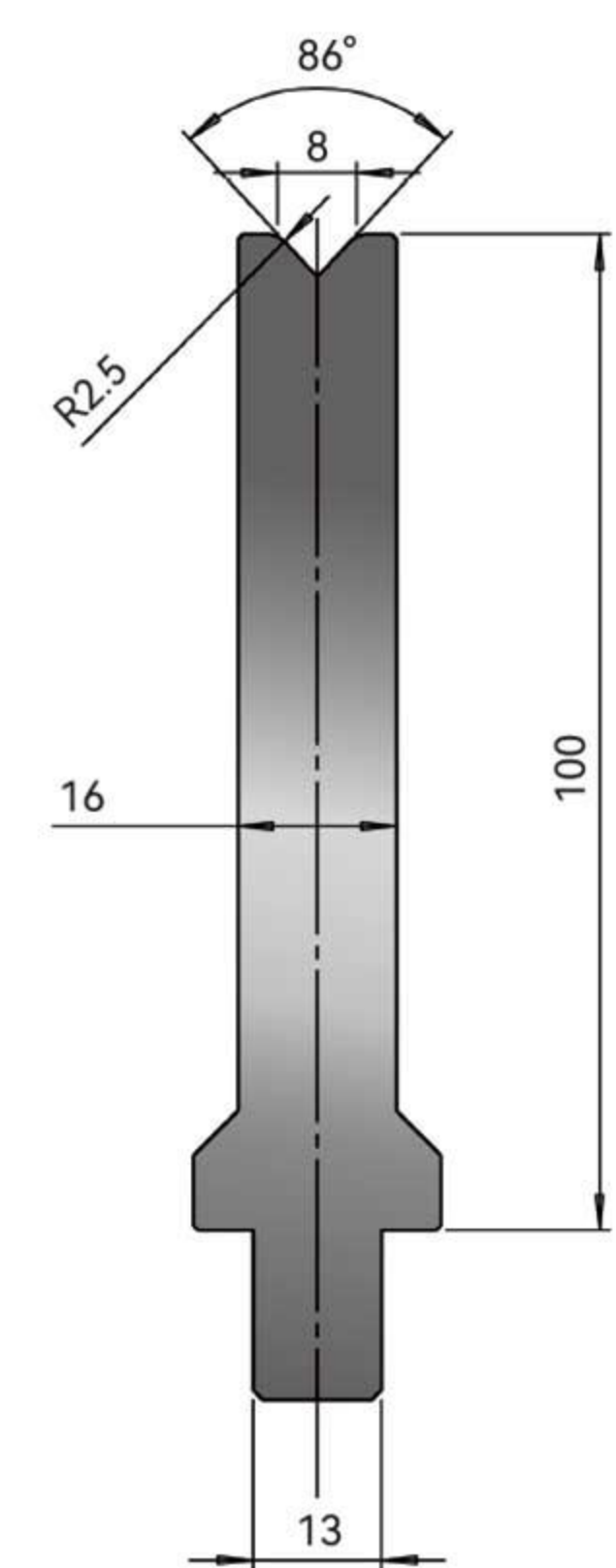

ZWD310

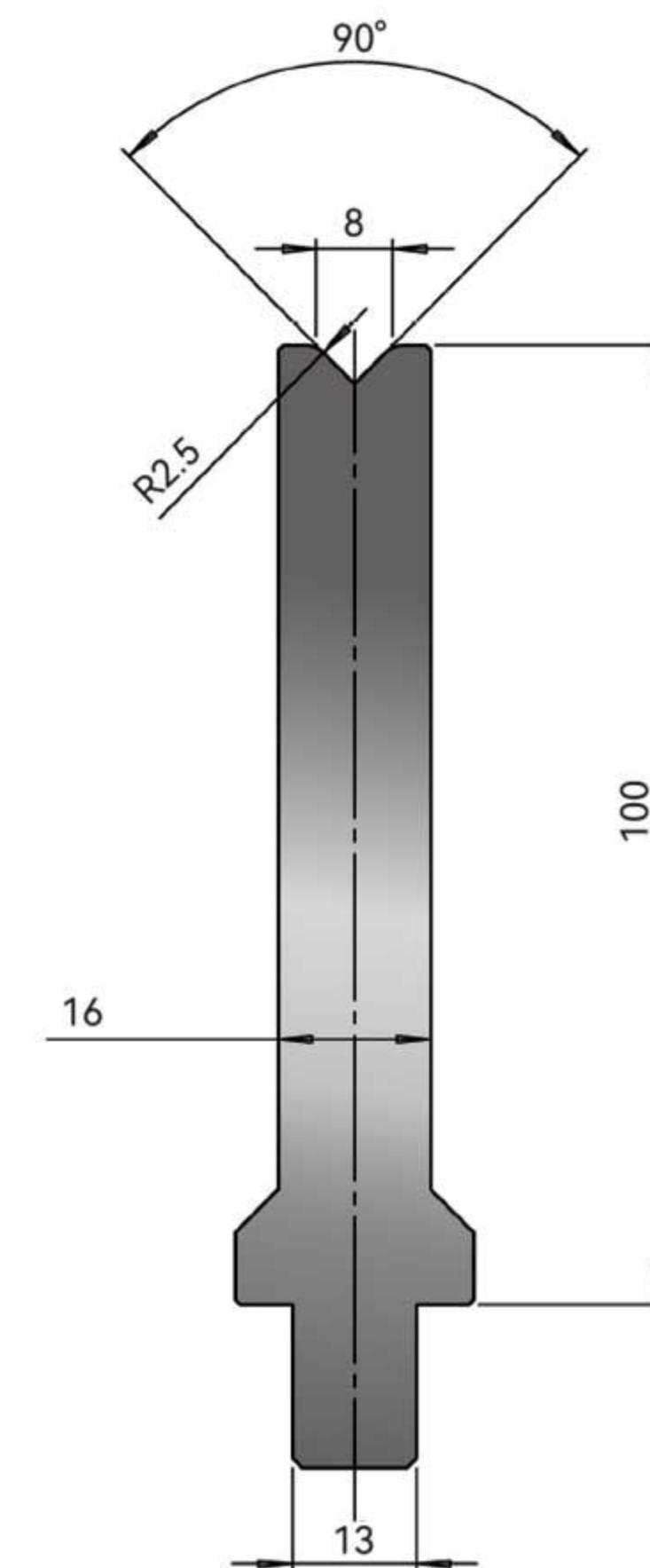

ZWD342

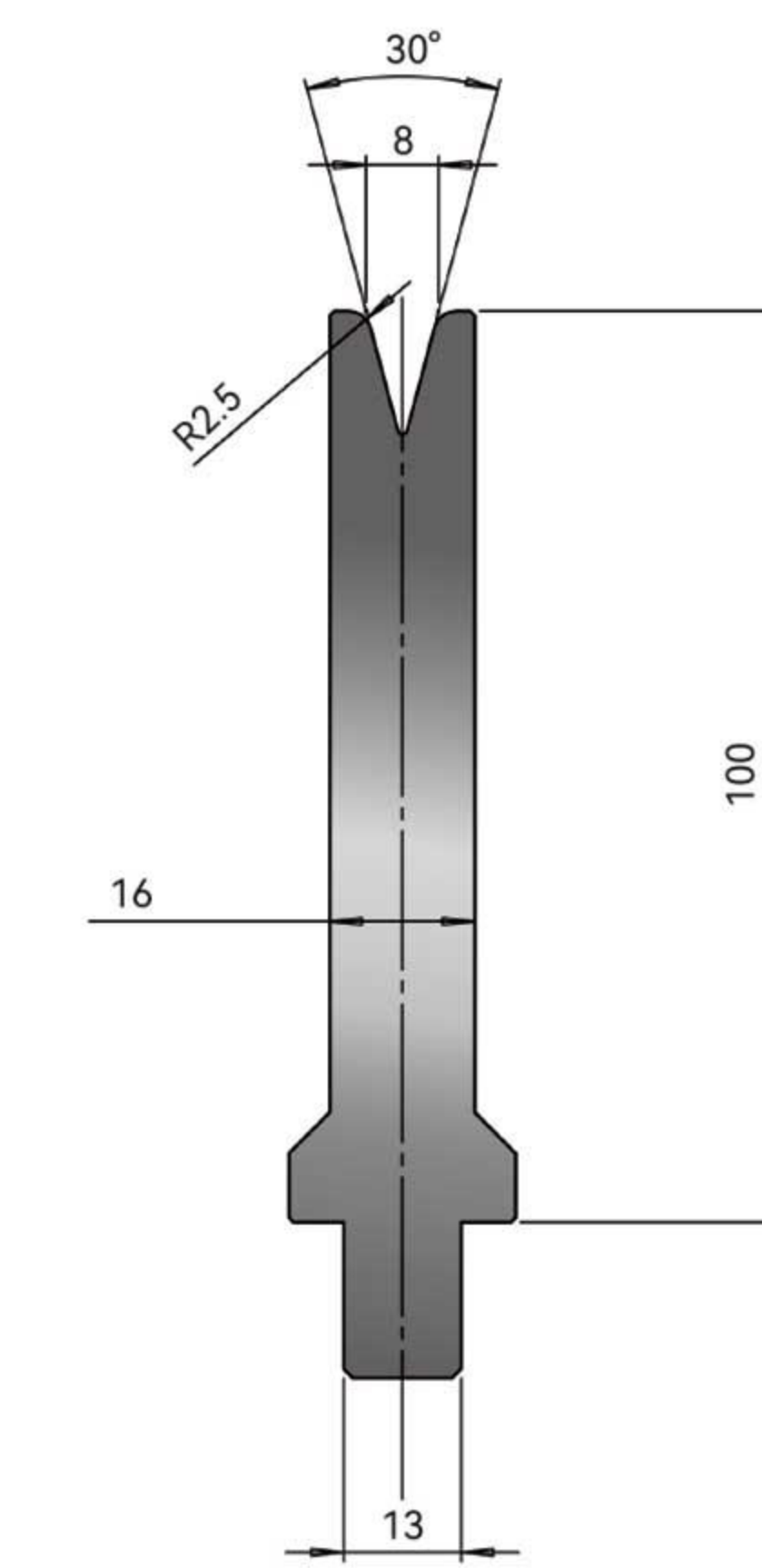

ZWD351

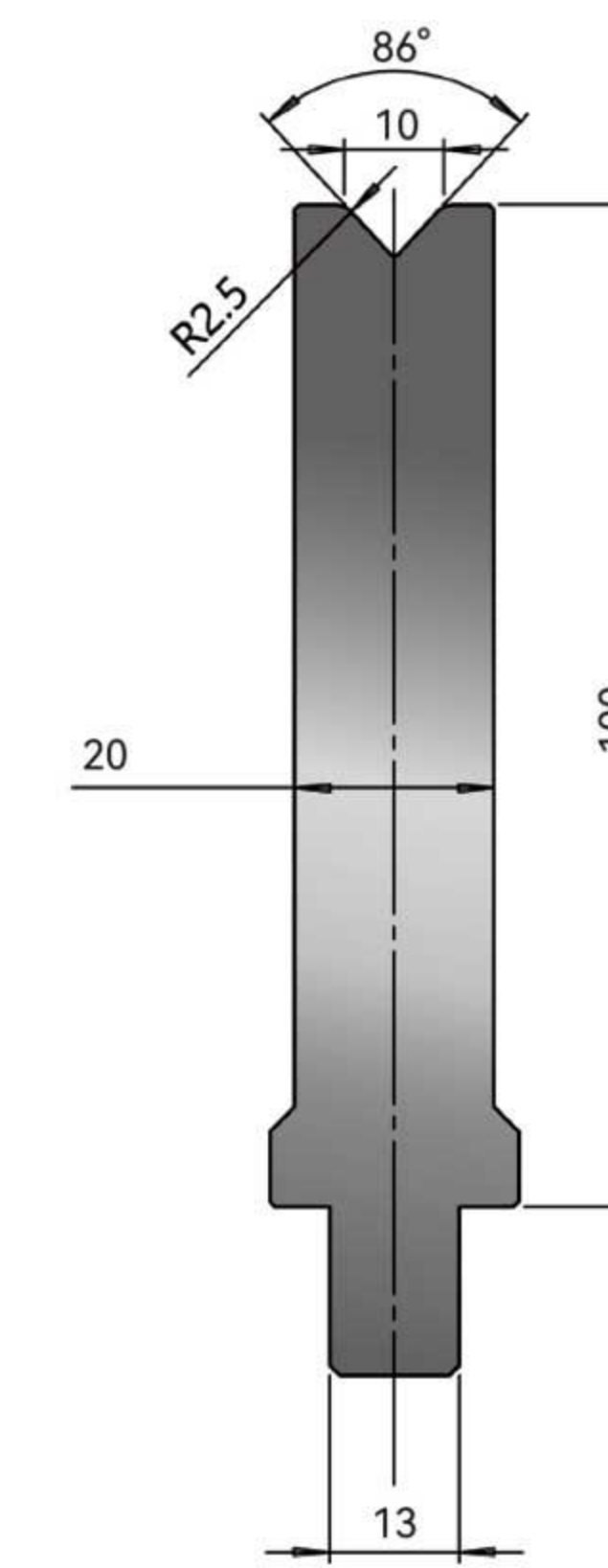

ZWD322

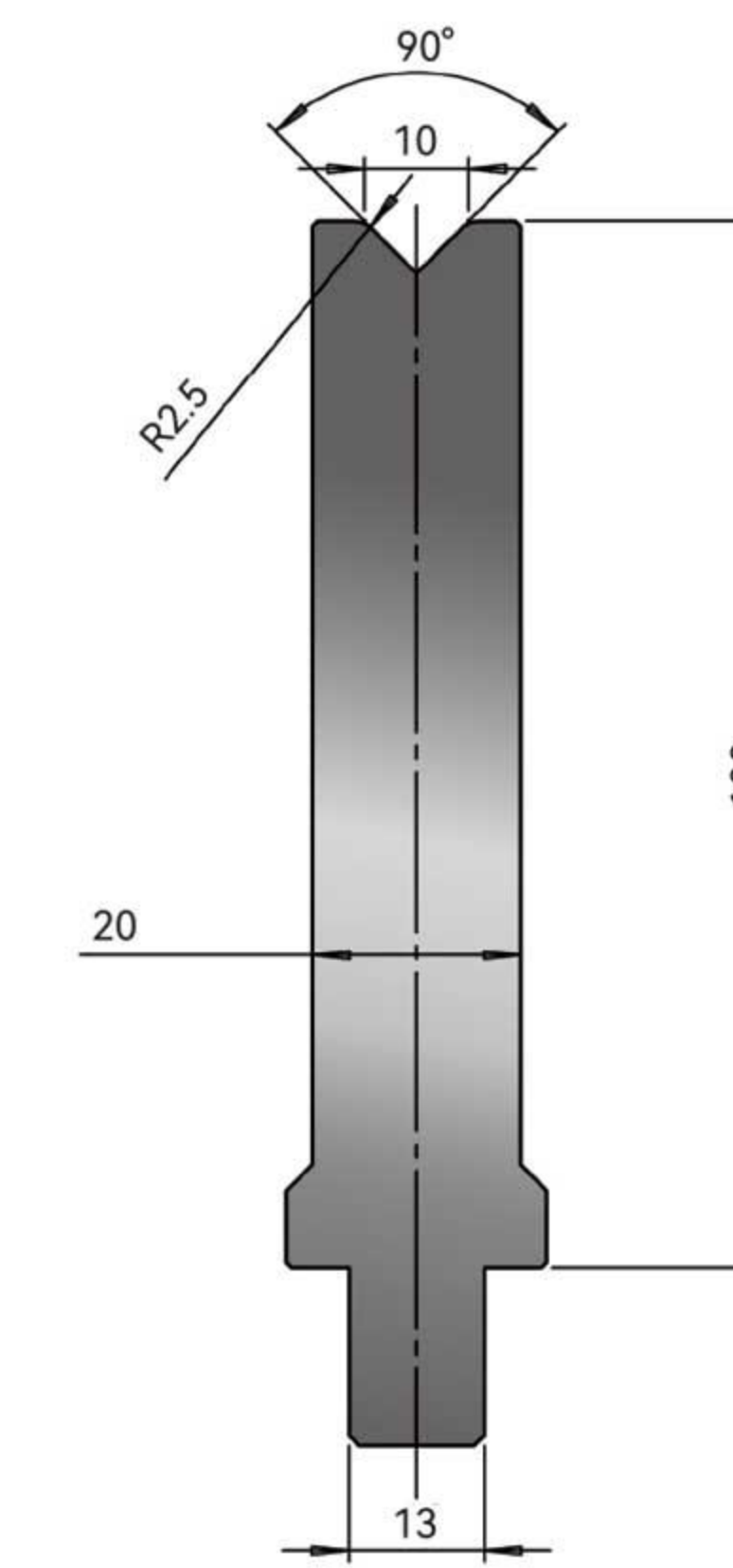

ZWD343

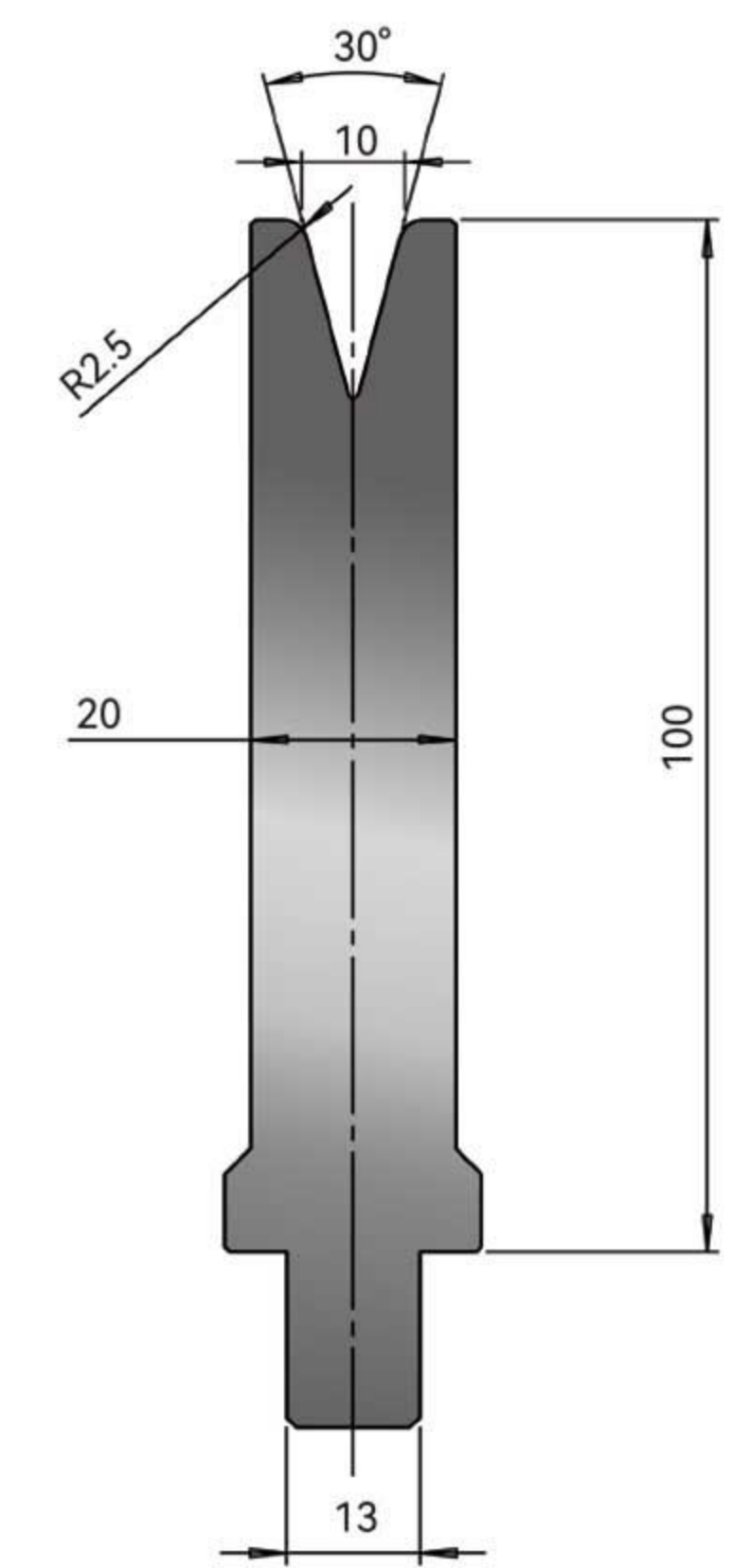

ZWD362

BENDMAX CAT.NO	WILA CAT.NO	Max Loading (t/m)	Weight (kg/m)
ZWD010	OZU-010	120	9.5
ZWD042	OZU-042	120	9.5
ZWD051	OZU-051	80	9.5
ZWD310	OZU-310	120	15
ZWD342	OZU-342	120	15
ZWD351	OZU-351	80	15

BENDMAX CAT.NO	WILA CAT.NO	Max Loading (t/m)	Weight (kg/m)
ZWD022	OZU-022	120	11
ZWD043	OZU-043	120	11
ZWD062	OZU-062	80	10.5
ZWD322	OZU-322	120	18
ZWD343	OZU-343	120	18
ZWD362	OZU-362	80	17.5



Die V=12mm

PRESSBRAKE TOOLS-BENDMAX-WILASTYLE



Die V=16mm

PRESSBRAKE TOOLS-BENDMAX-WILASTYLE

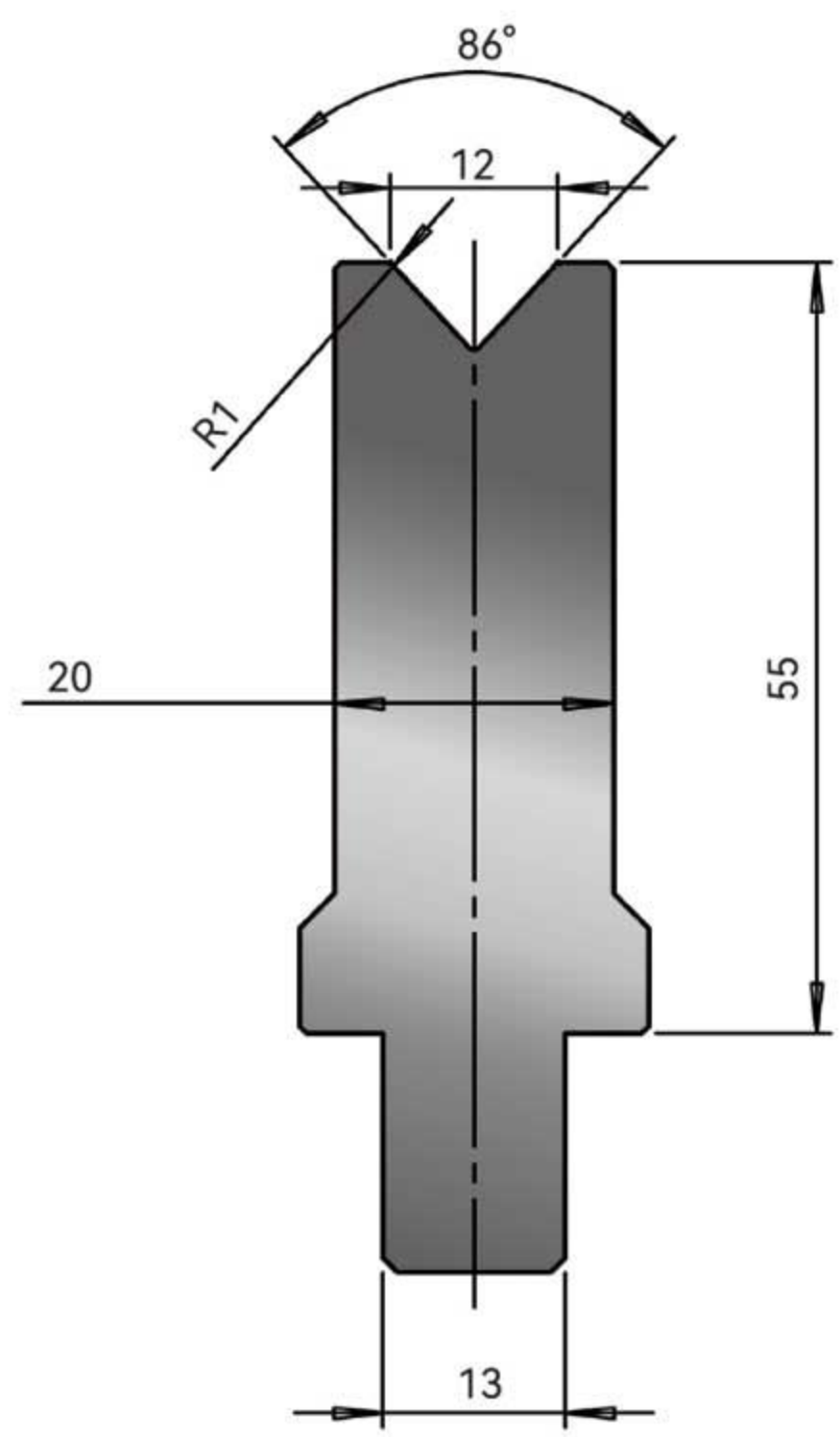

ZWD011

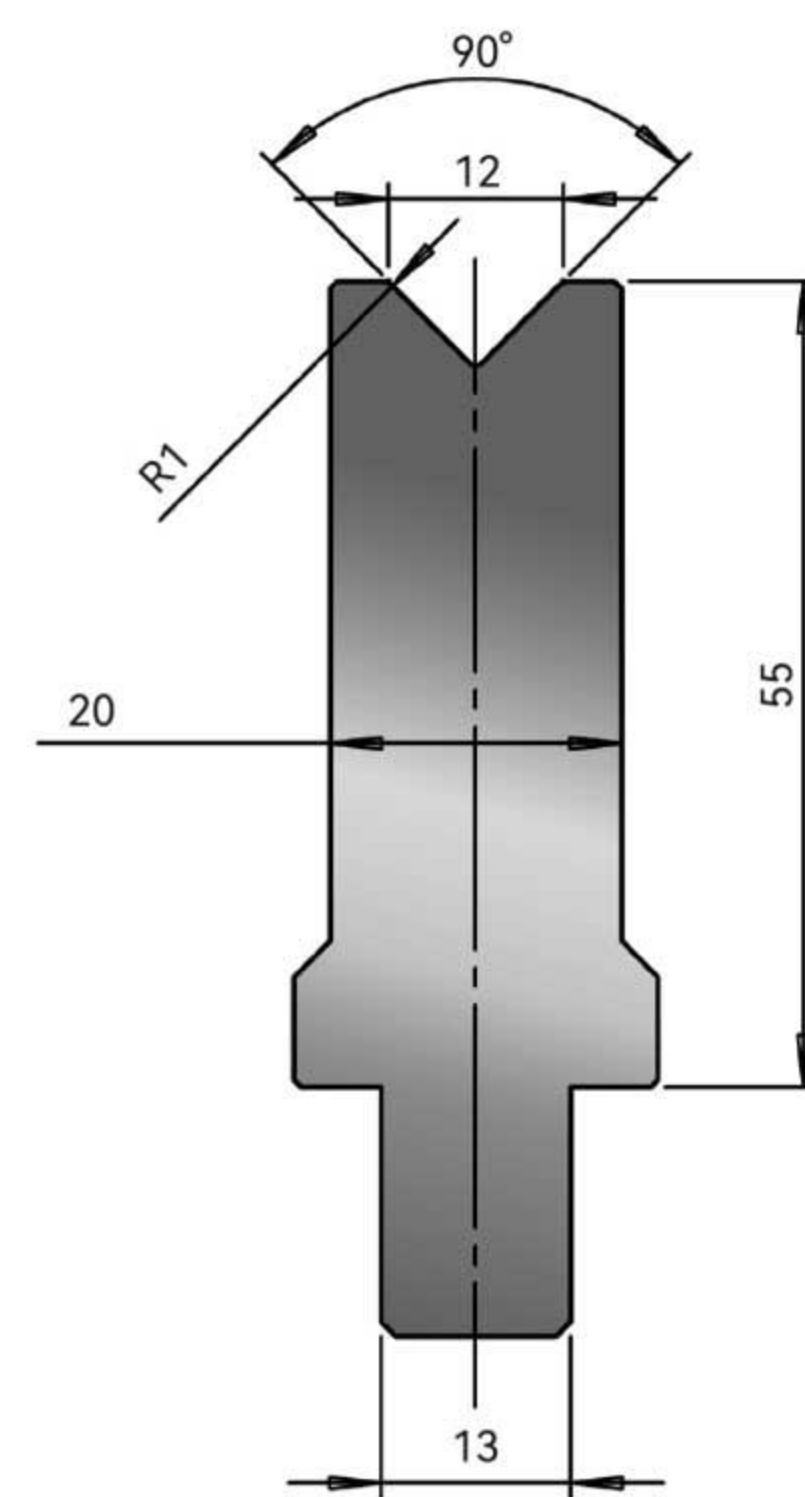

ZWD044

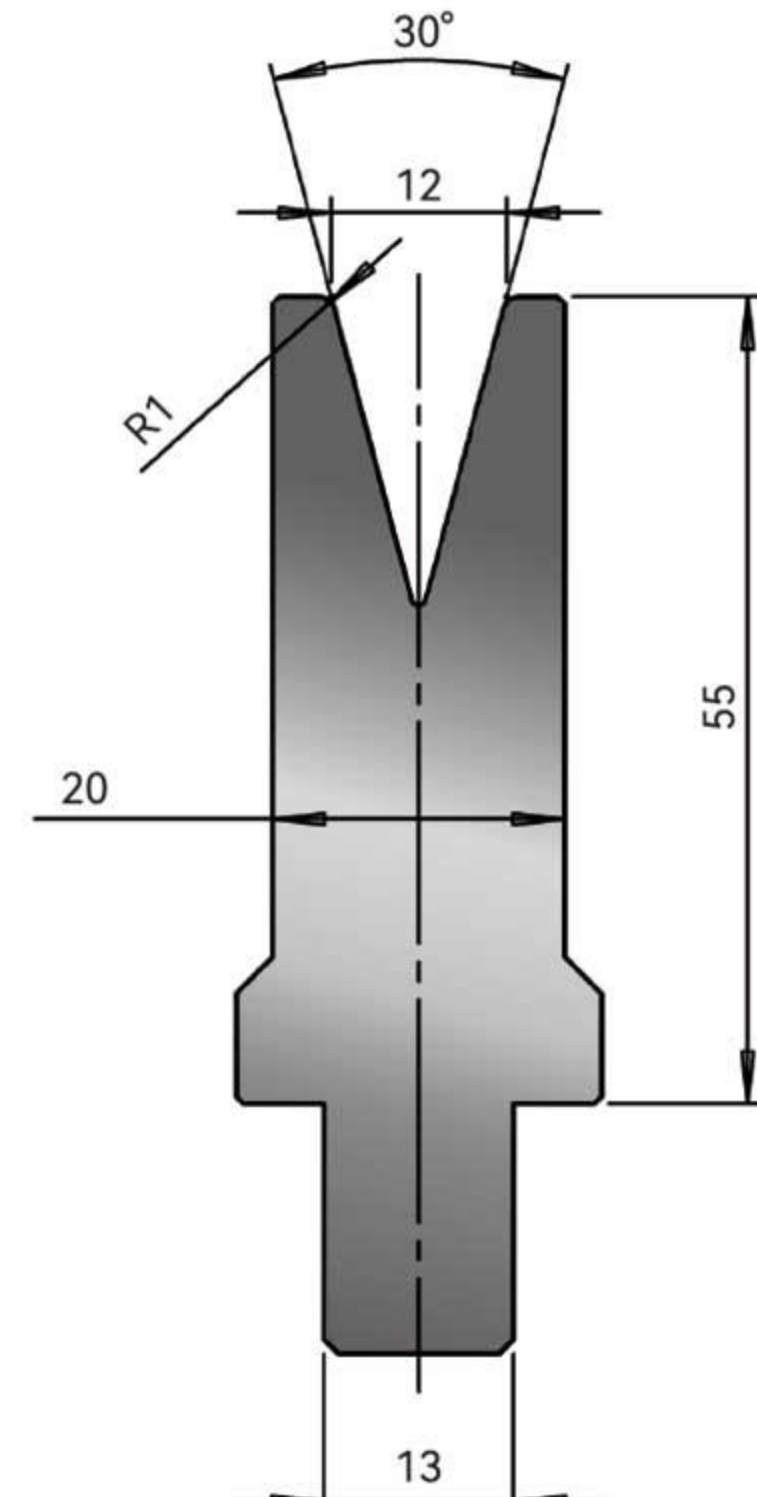

ZWD052

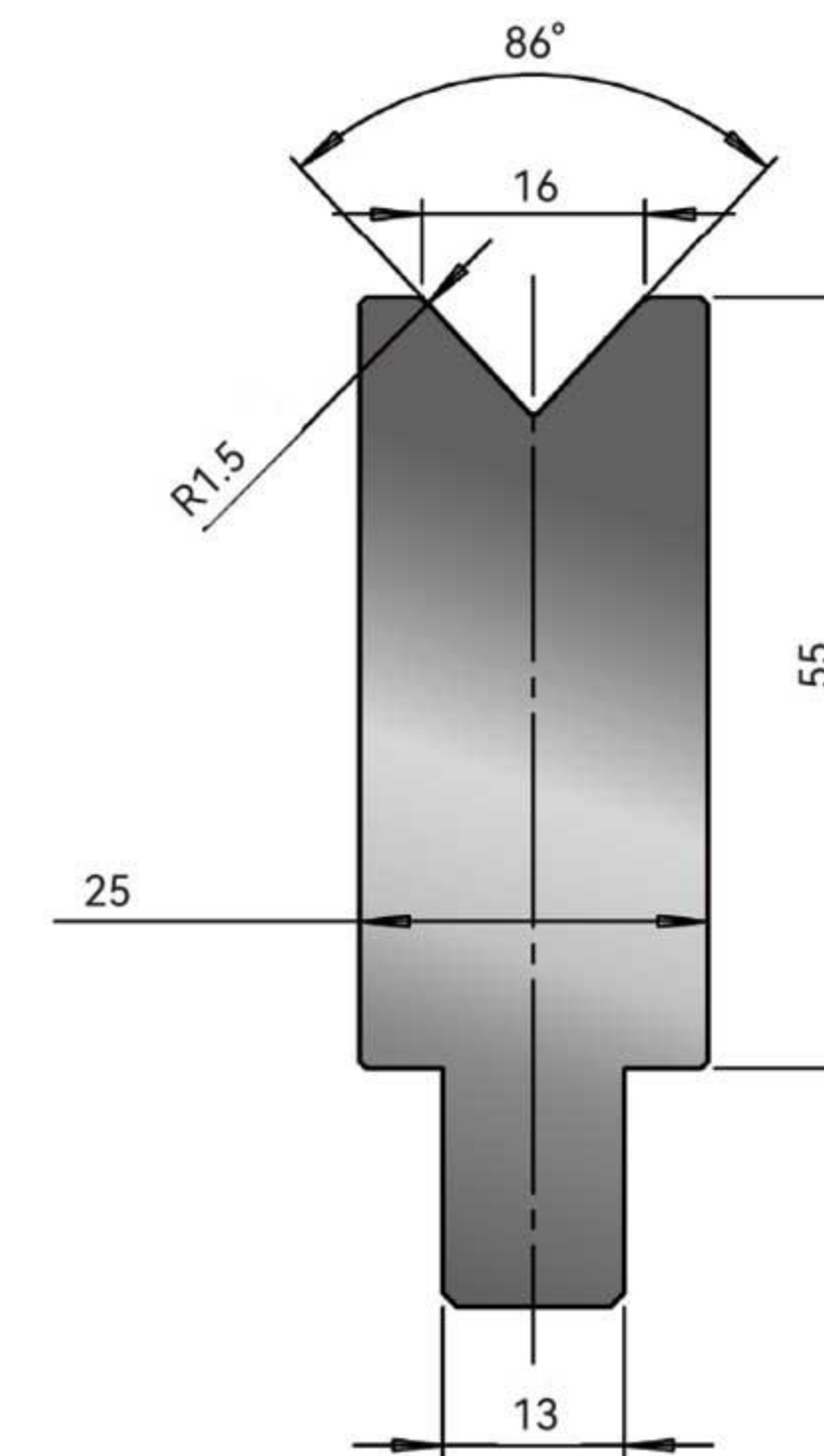

ZWD012

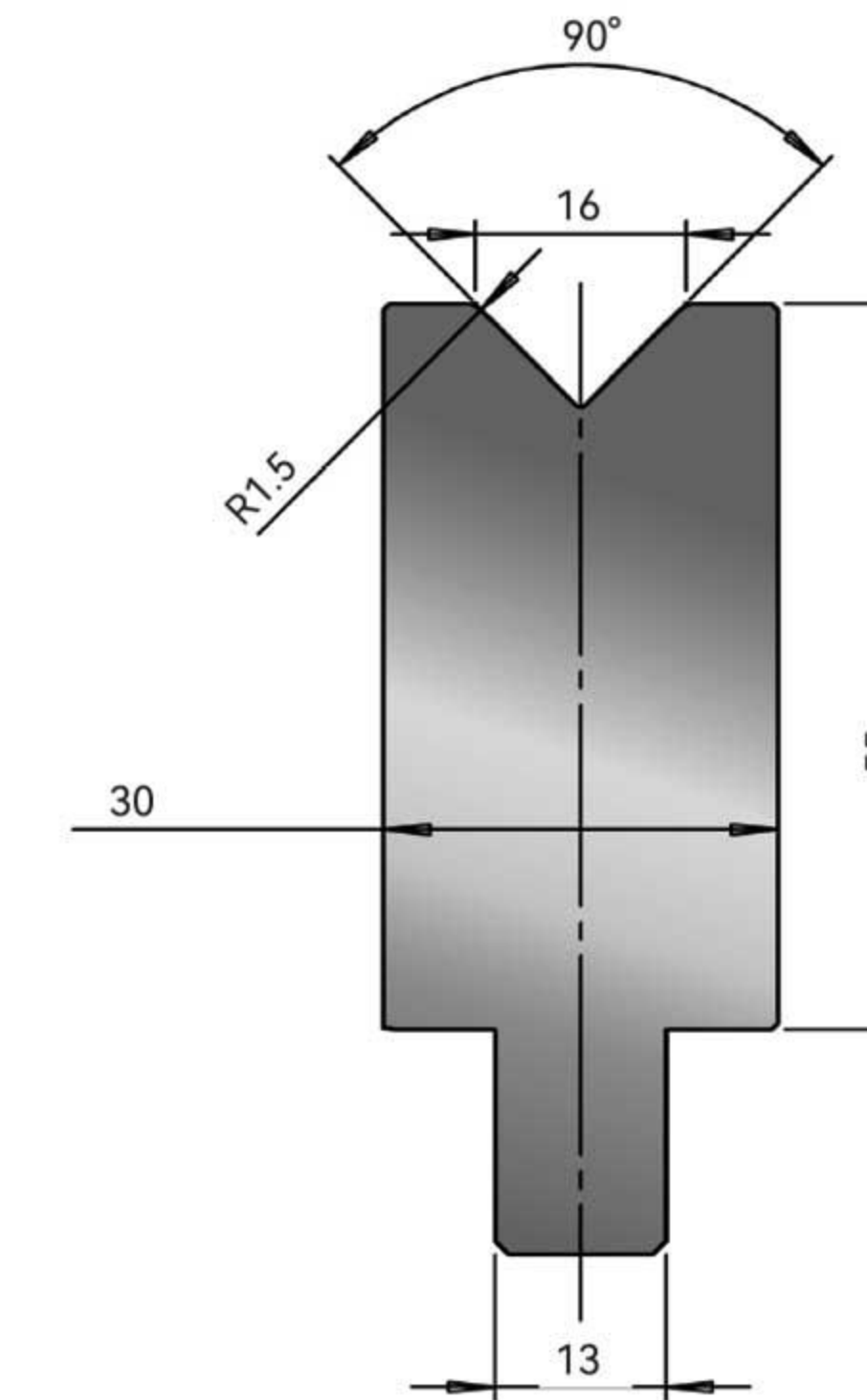

ZWD045

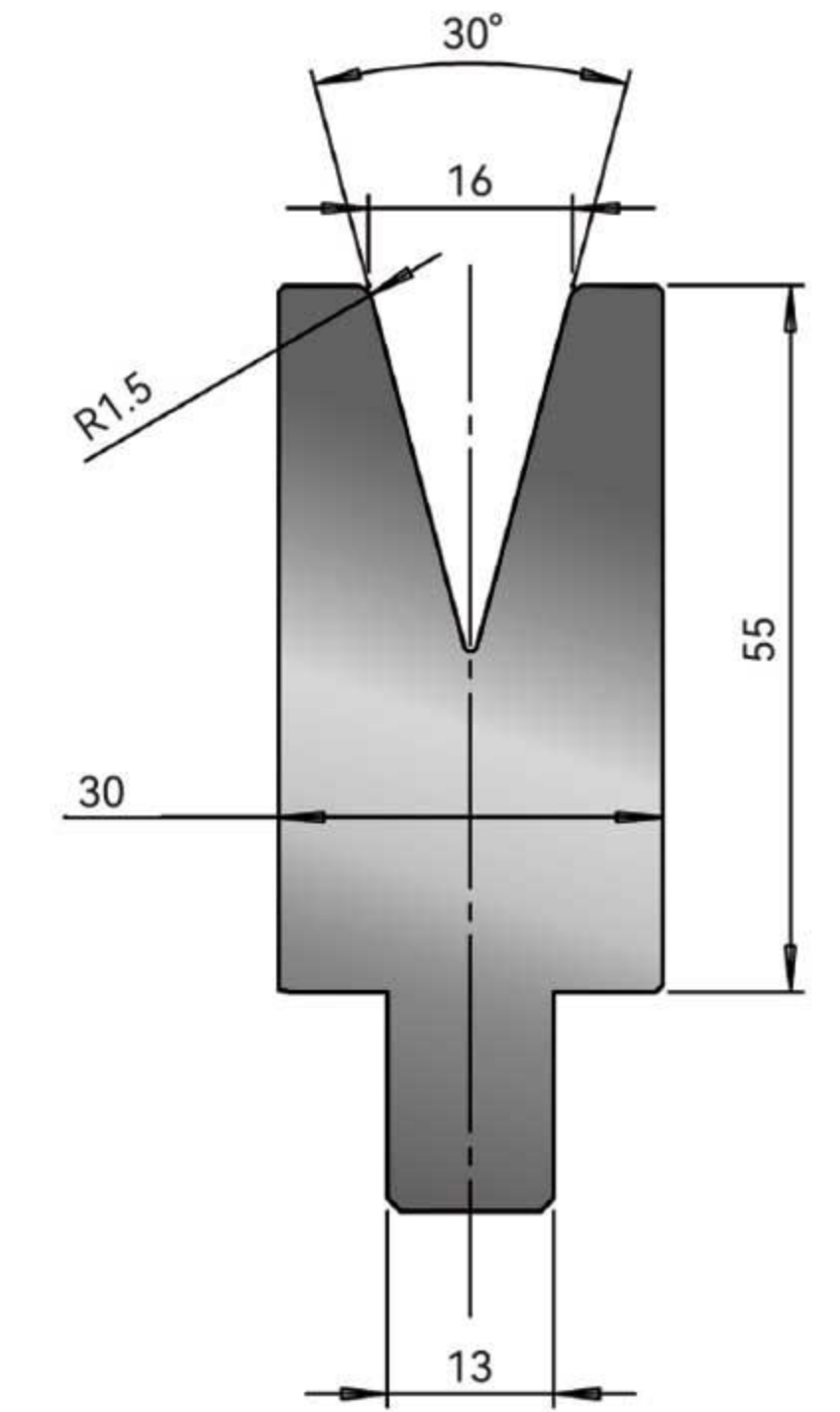

ZWD053

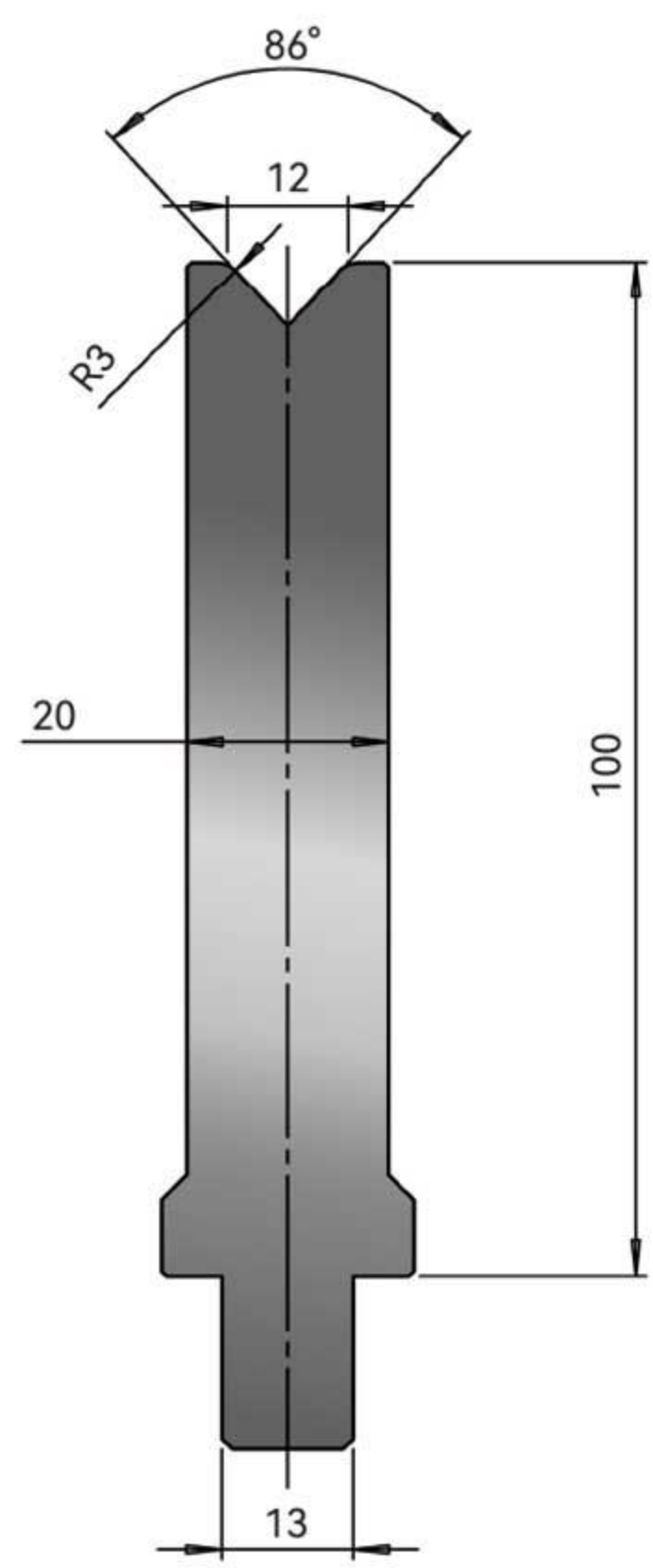

ZWD311

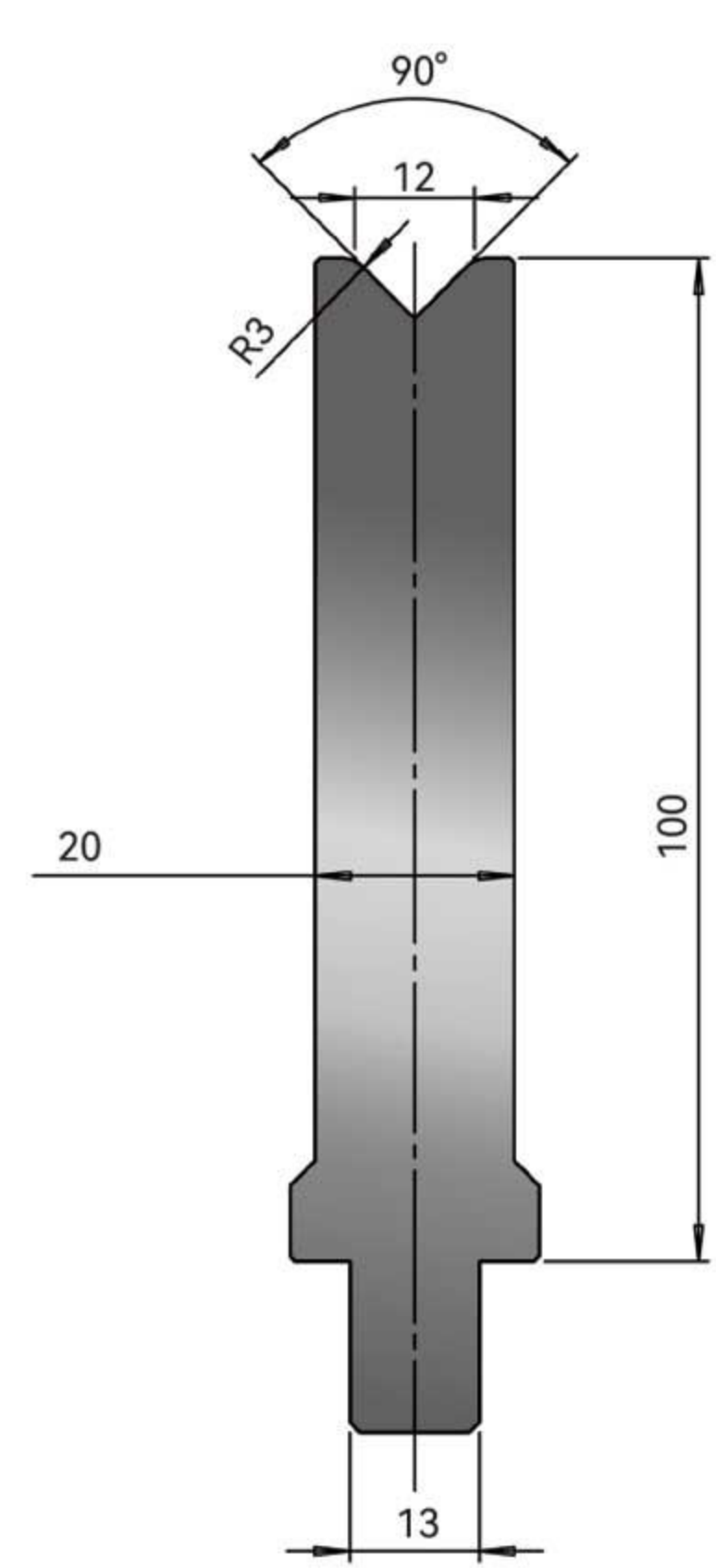

ZWD344

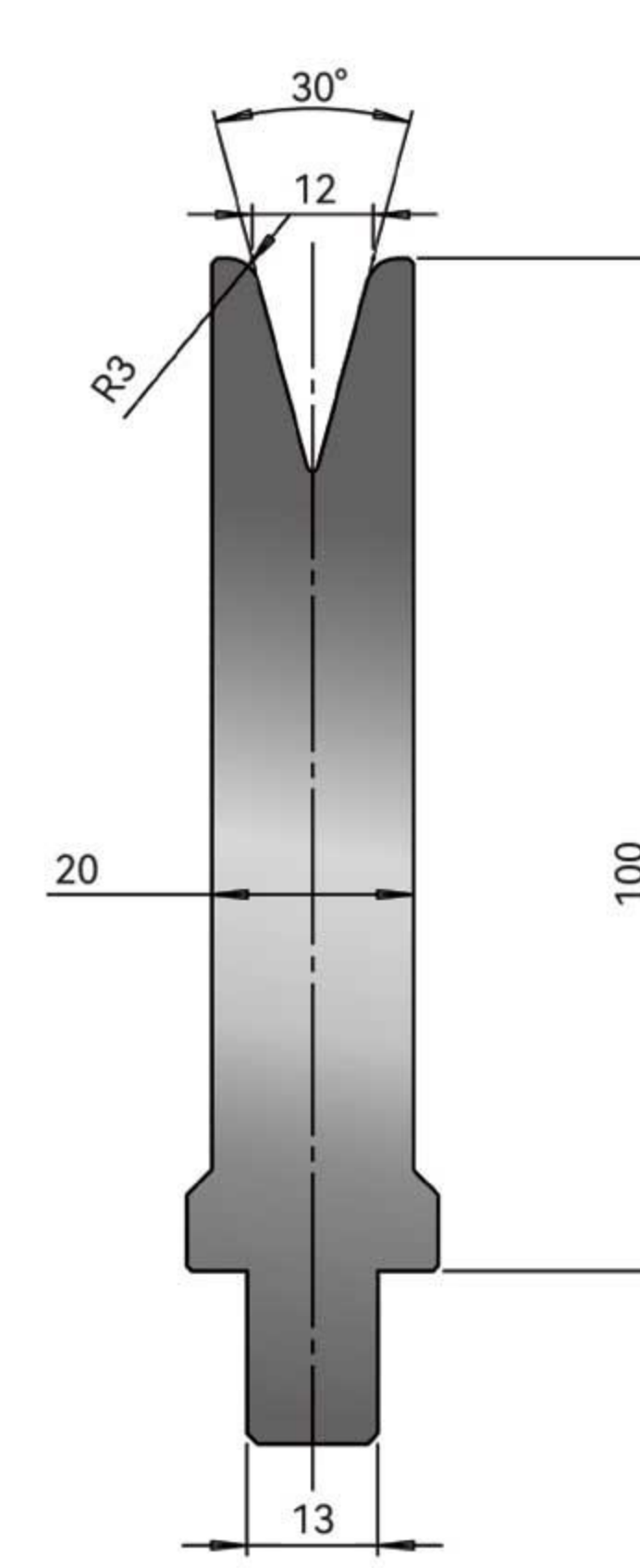

ZWD352

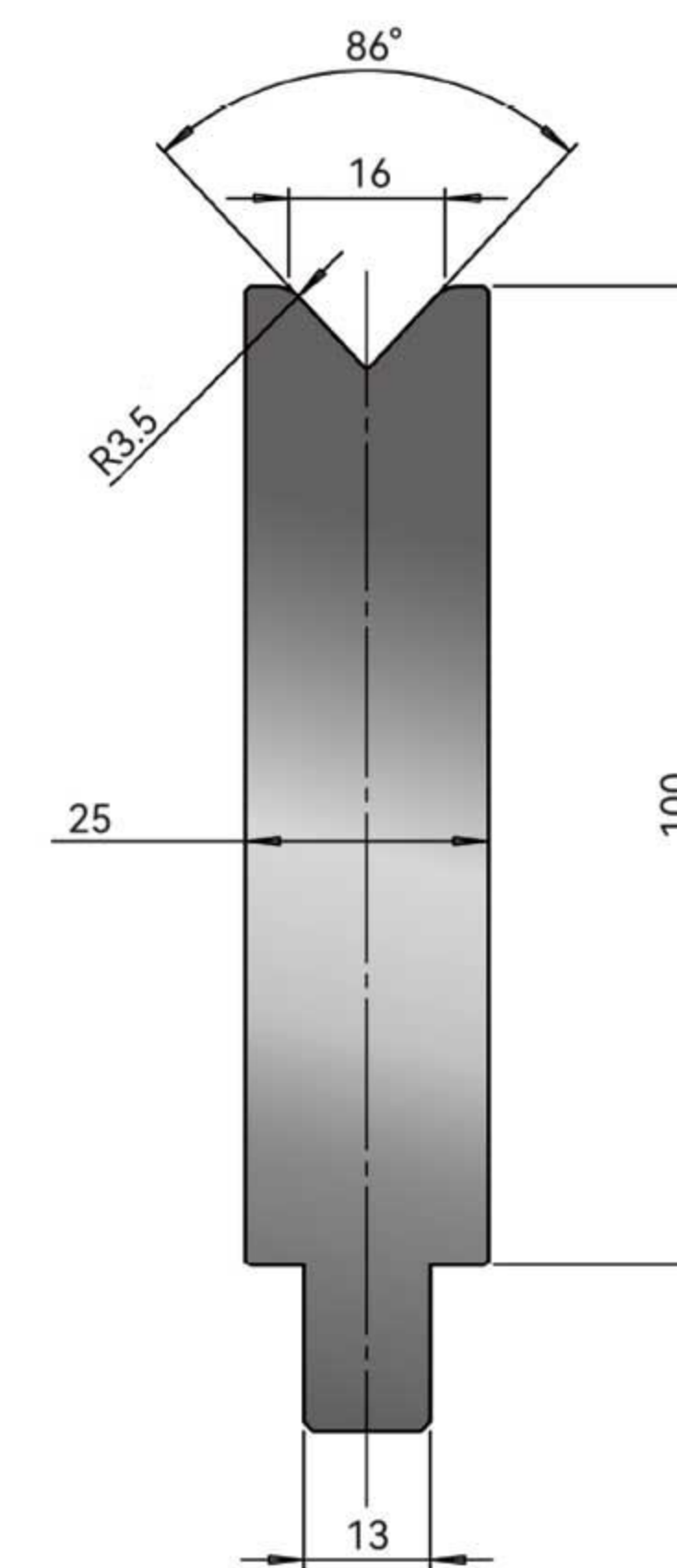

ZWD312

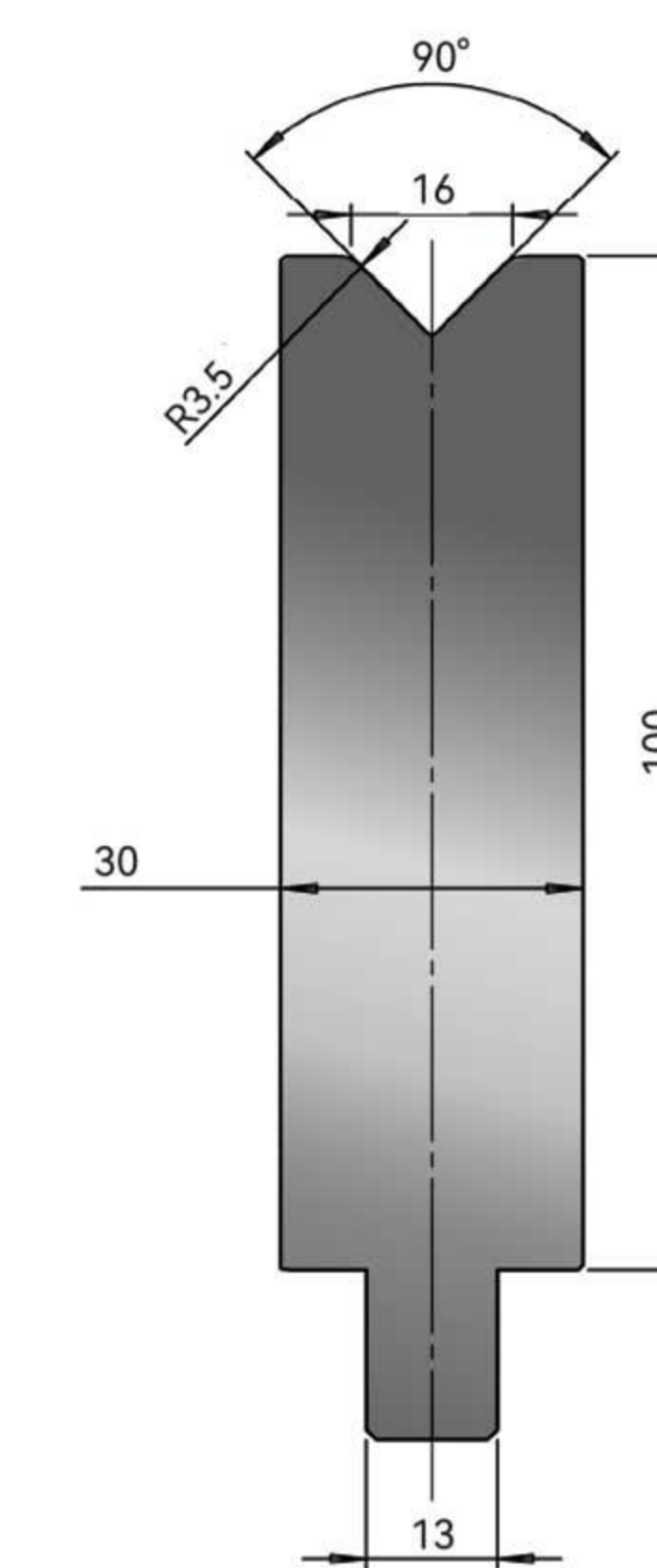

ZWD345

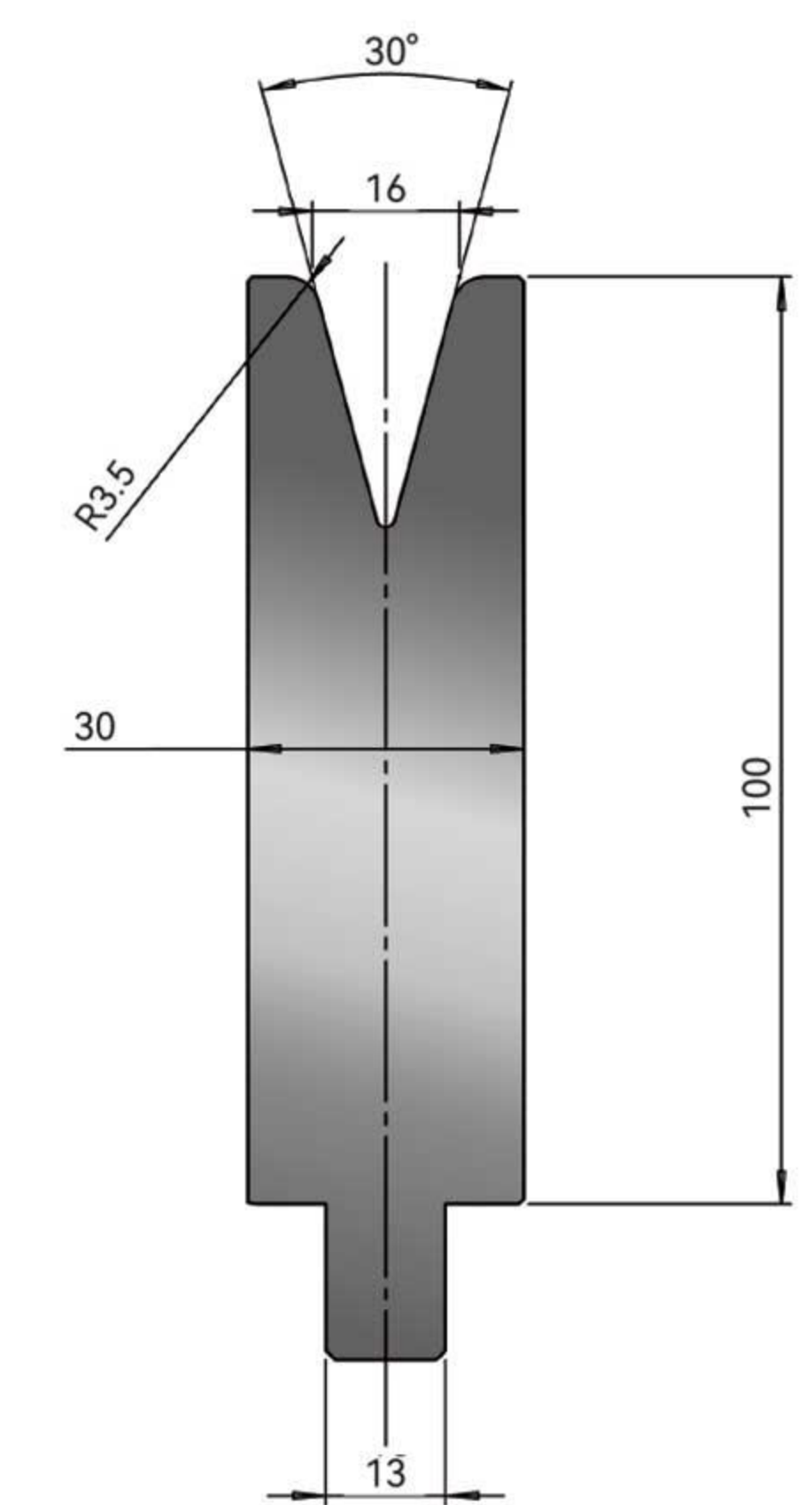

ZWD353

BENDMAX CAT.NO	WILA CAT.NO	Max Loading (t/m)	Weight (kg/m)
ZWD011	OZU-011	120	11
ZWD044	OZU-044	120	11
ZWD052	OZU-052	80	10
ZWD311	OZU-311	120	18
ZWD344	OZU-344	120	18
ZWD352	OZU-352	80	17.5

BENDMAX CAT.NO	WILA CAT.NO	Max Loading (t/m)	Weight (kg/m)
ZWD012	OZU-012	120	13
ZWD045	OZU-045	120	15
ZWD053	OZU-053	80	13.5
ZWD312	OZU-312	120	19.5
ZWD345	OZU-345	120	24.5
ZWD353	OZU-353	80	24



Die V=20mm

PRESSBRAKE TOOLS-BENDMAX-WILASTYLE

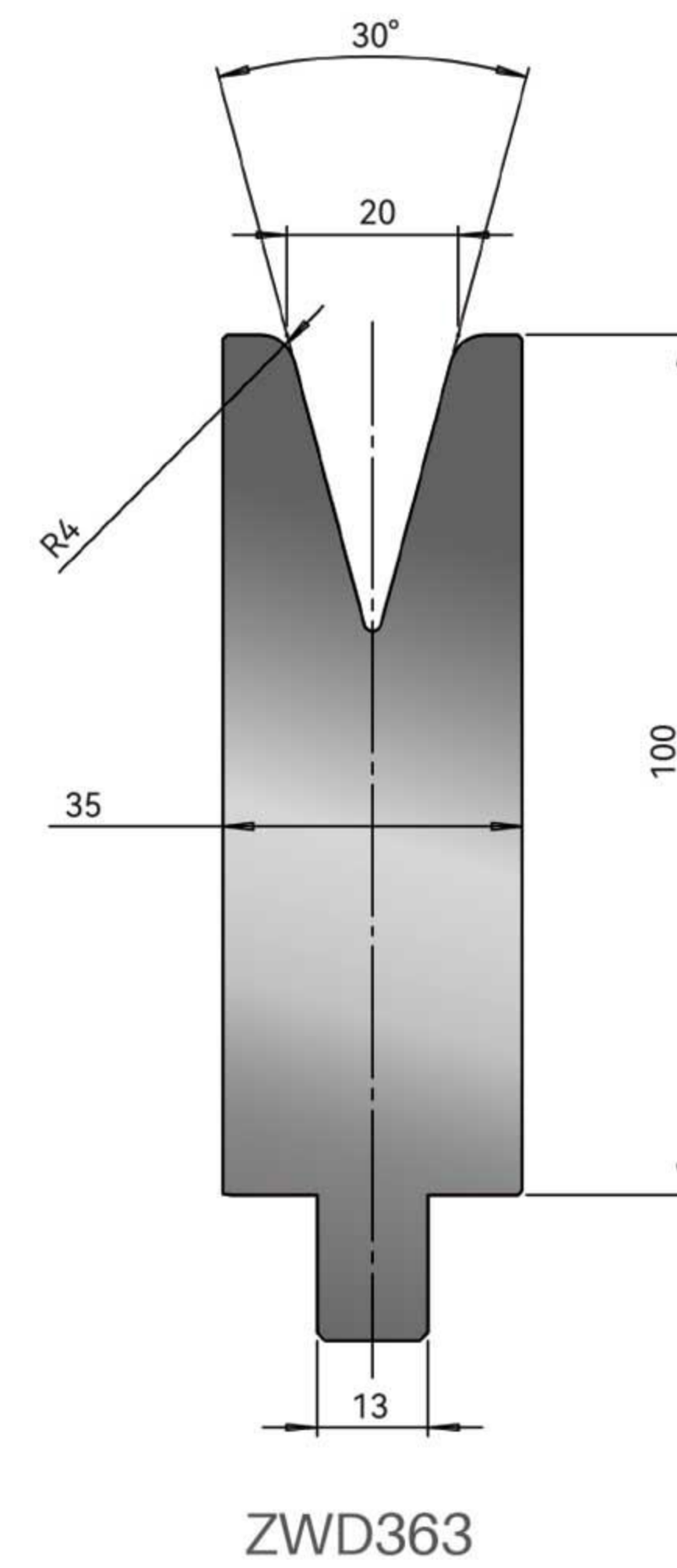
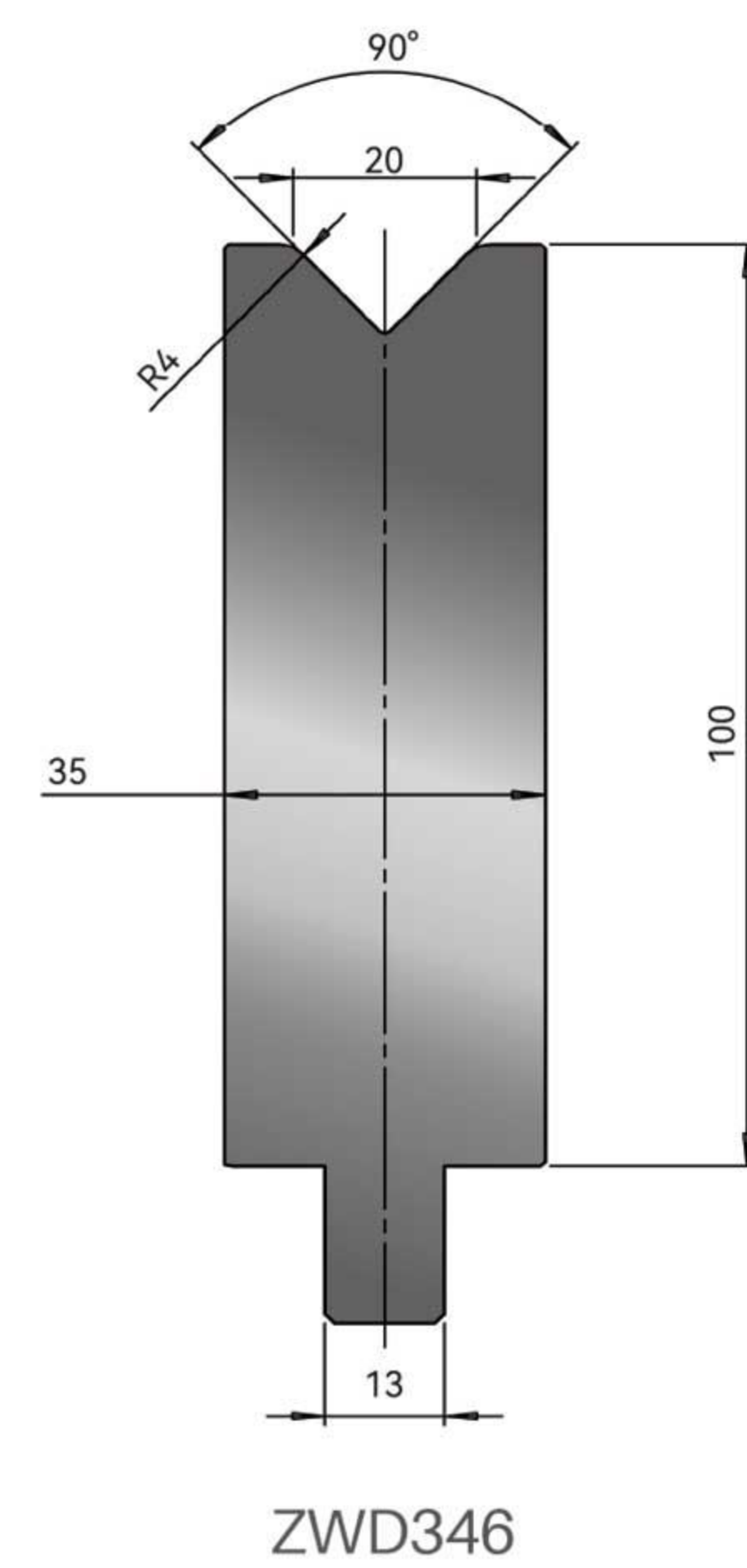
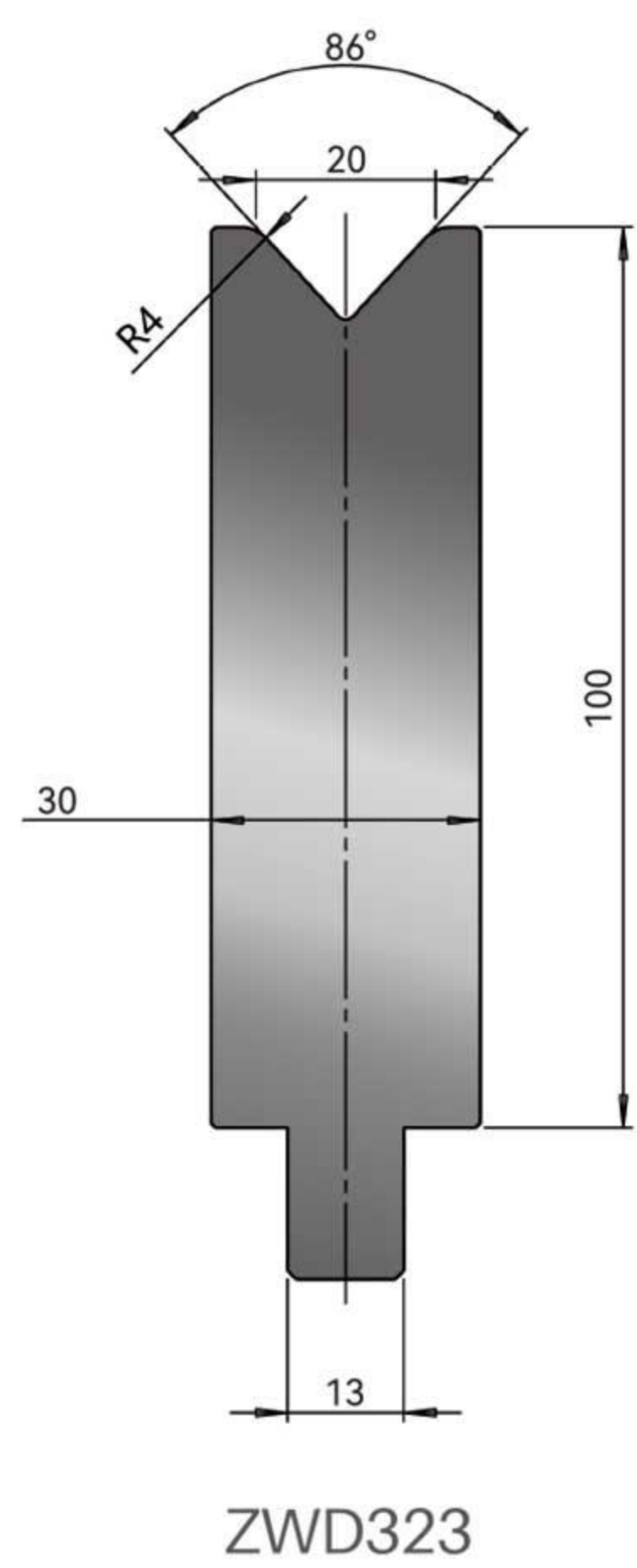
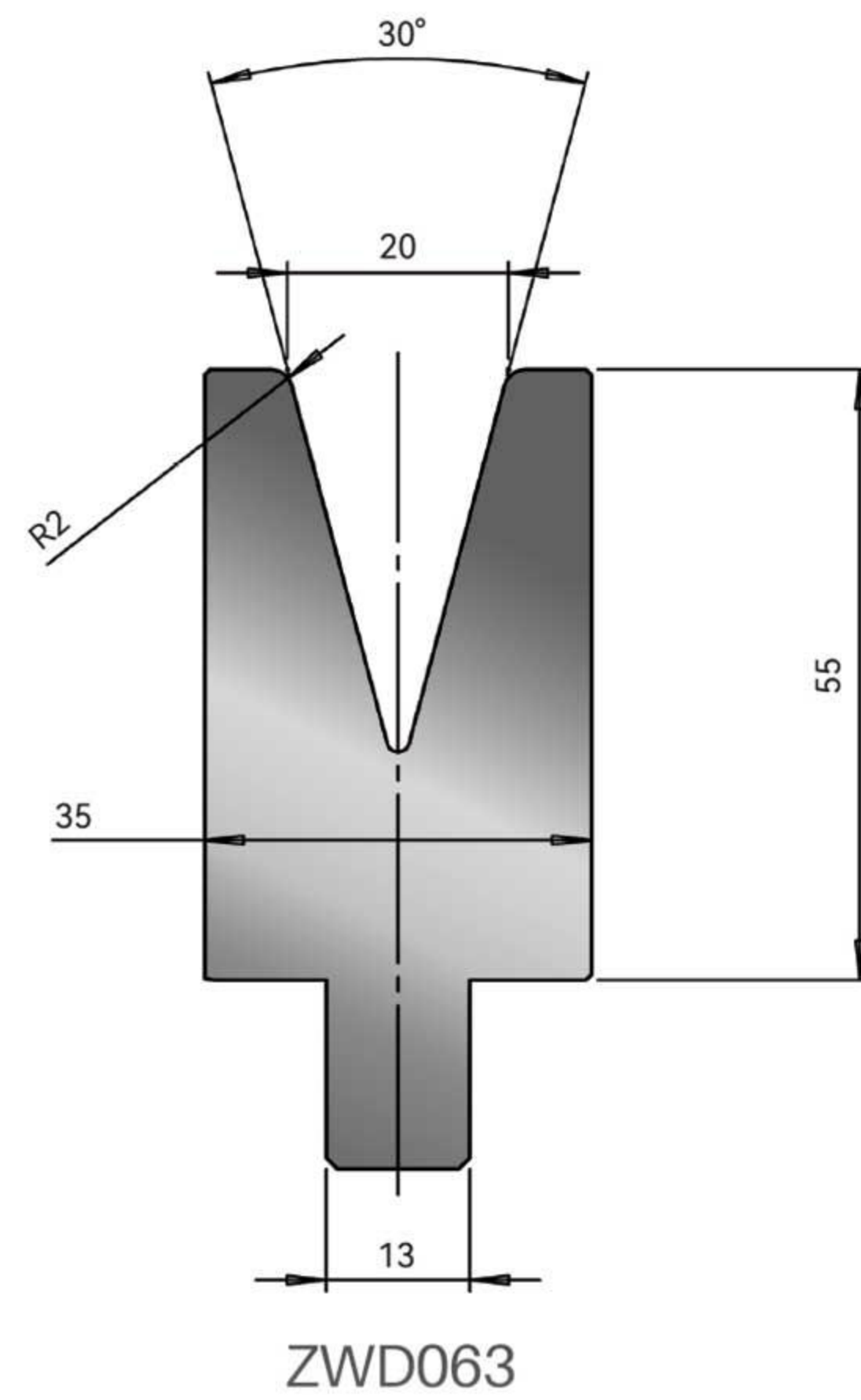
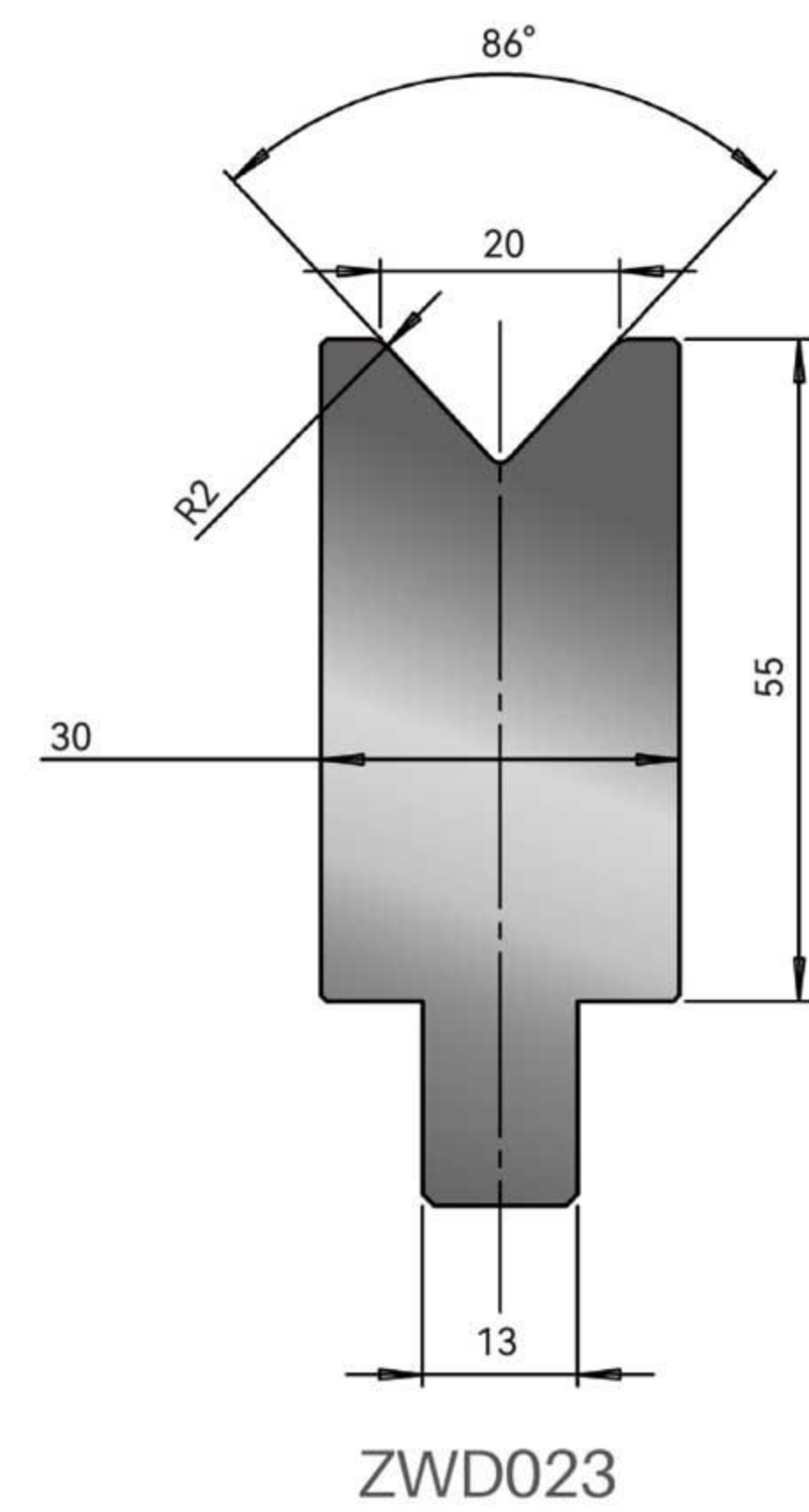

BENDMAX CAT.NO	WILA CAT.NO	Max Loading (t/m)	Weight (kg/m)
ZWD023	OZU-023	120	15
ZWD063	OZU-063	80	15
ZWD323	OZU-323	120	25
ZWD346	OZU-346	120	28.5
ZWD363	OZU-363	80	27



Die V=24mm

PRESSBRAKE TOOLS-BENDMAX-WILASTYLE

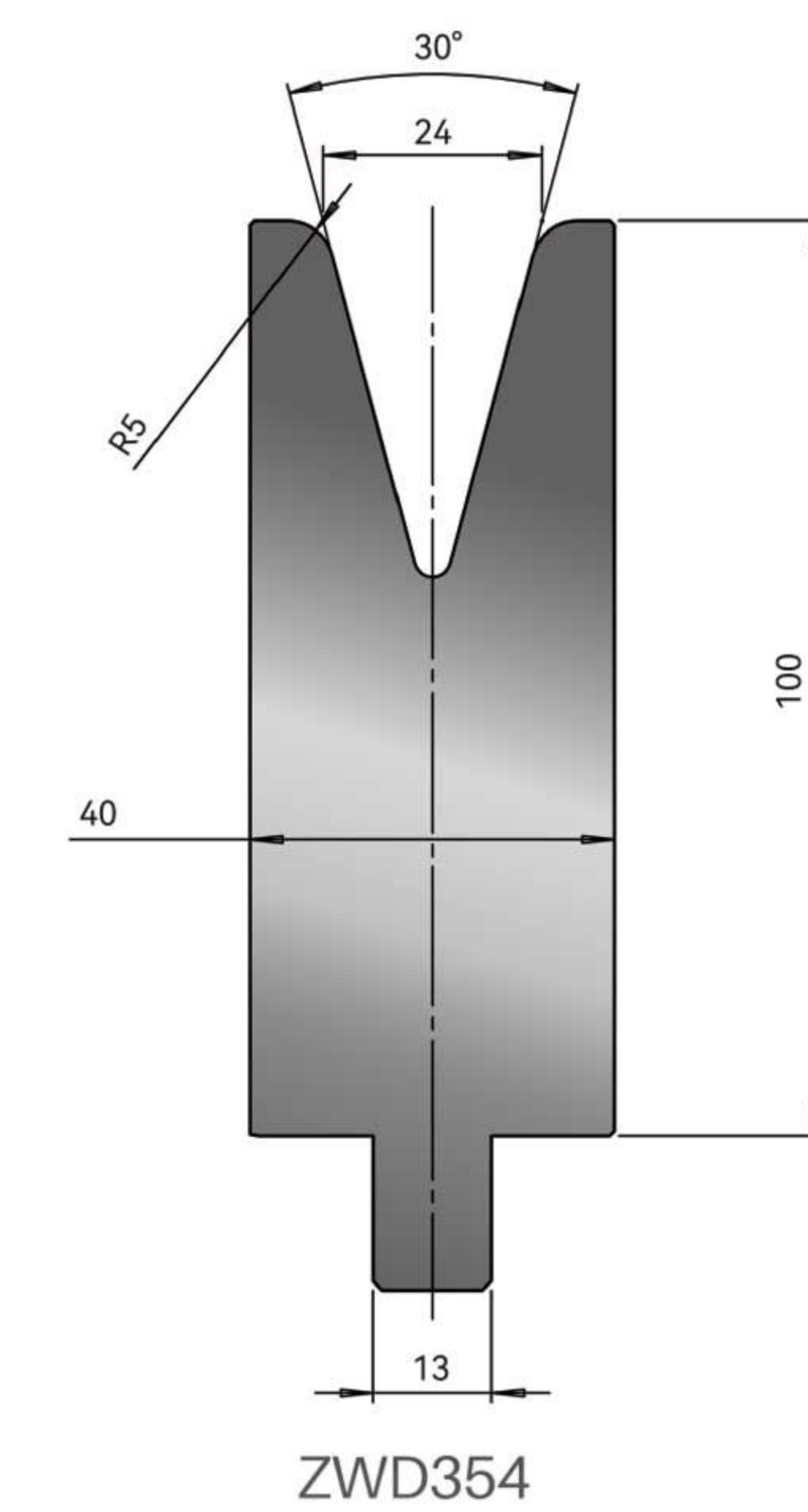
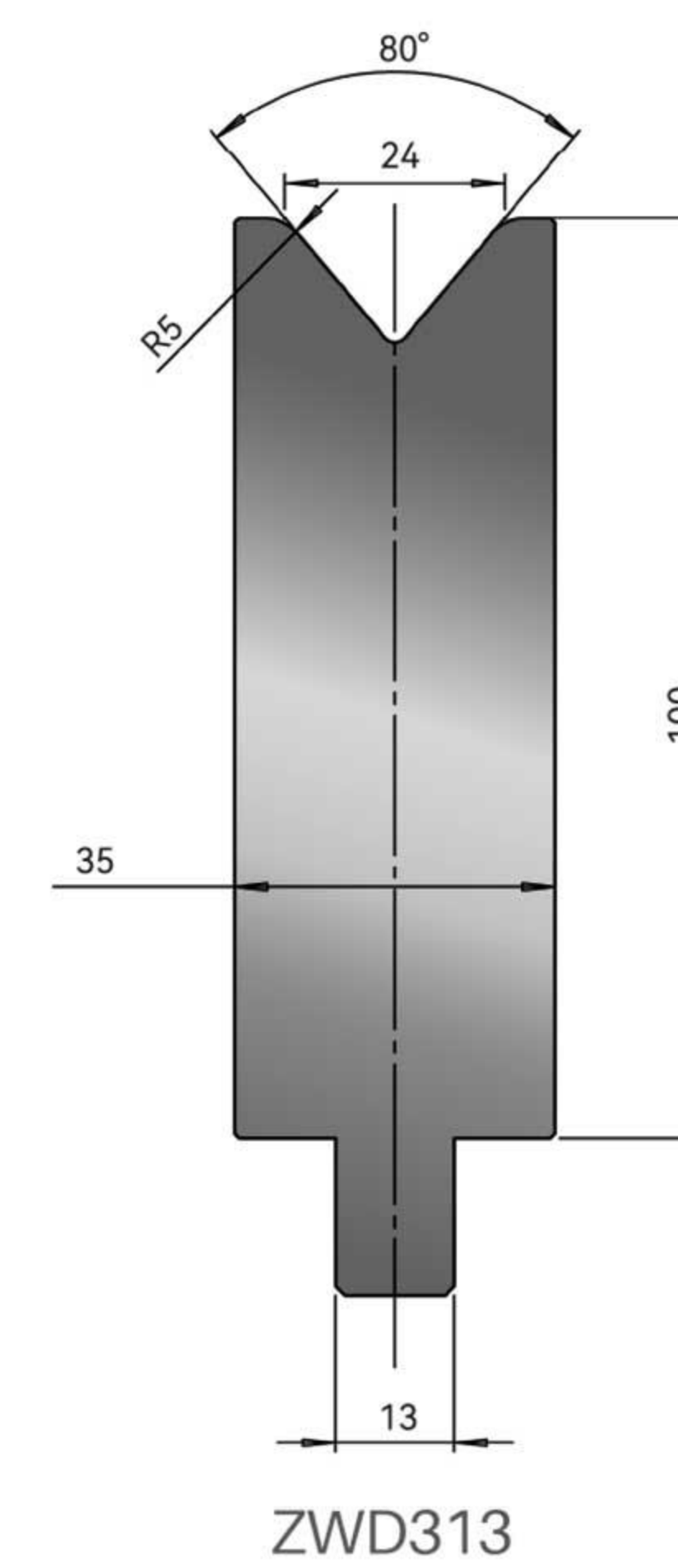
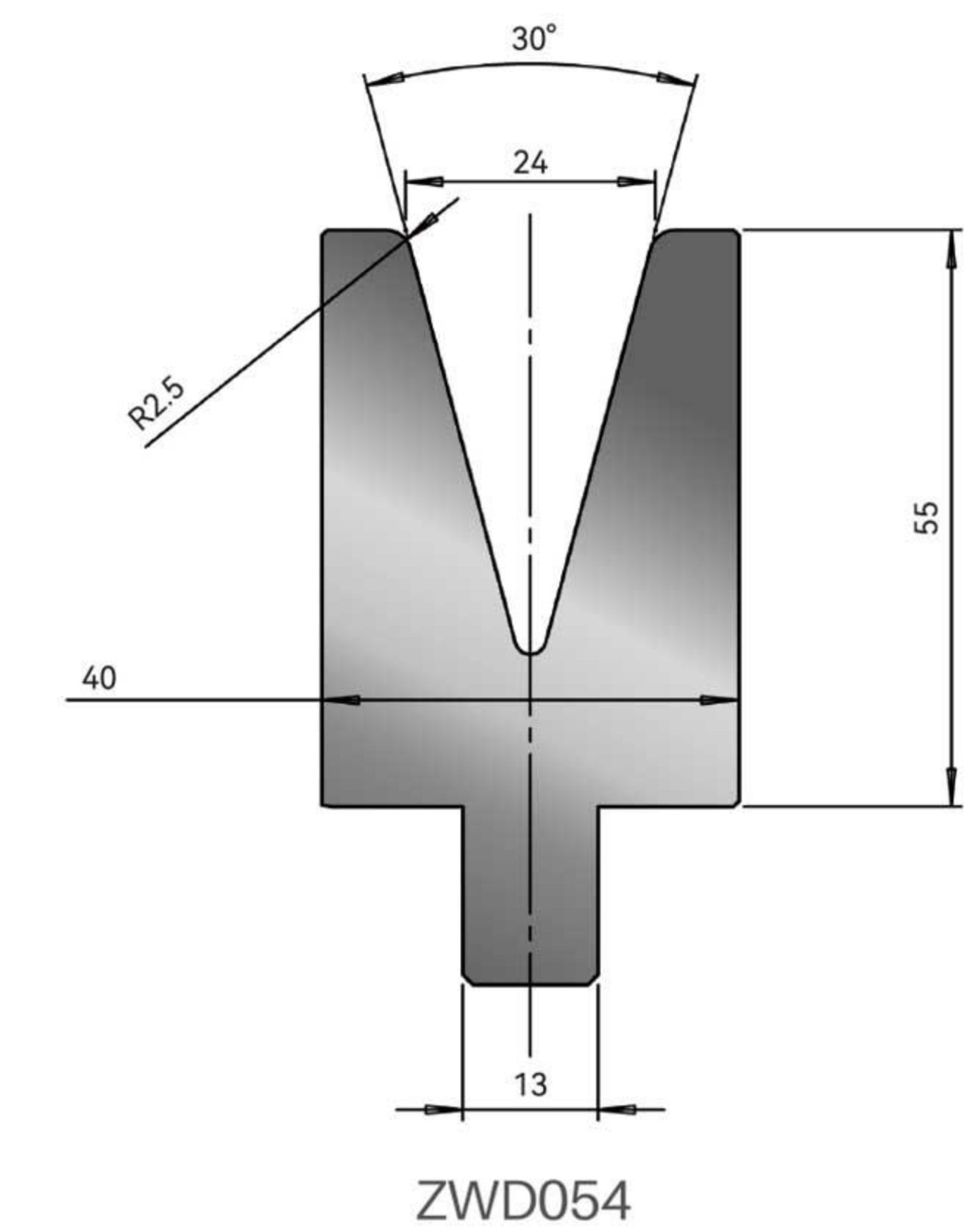
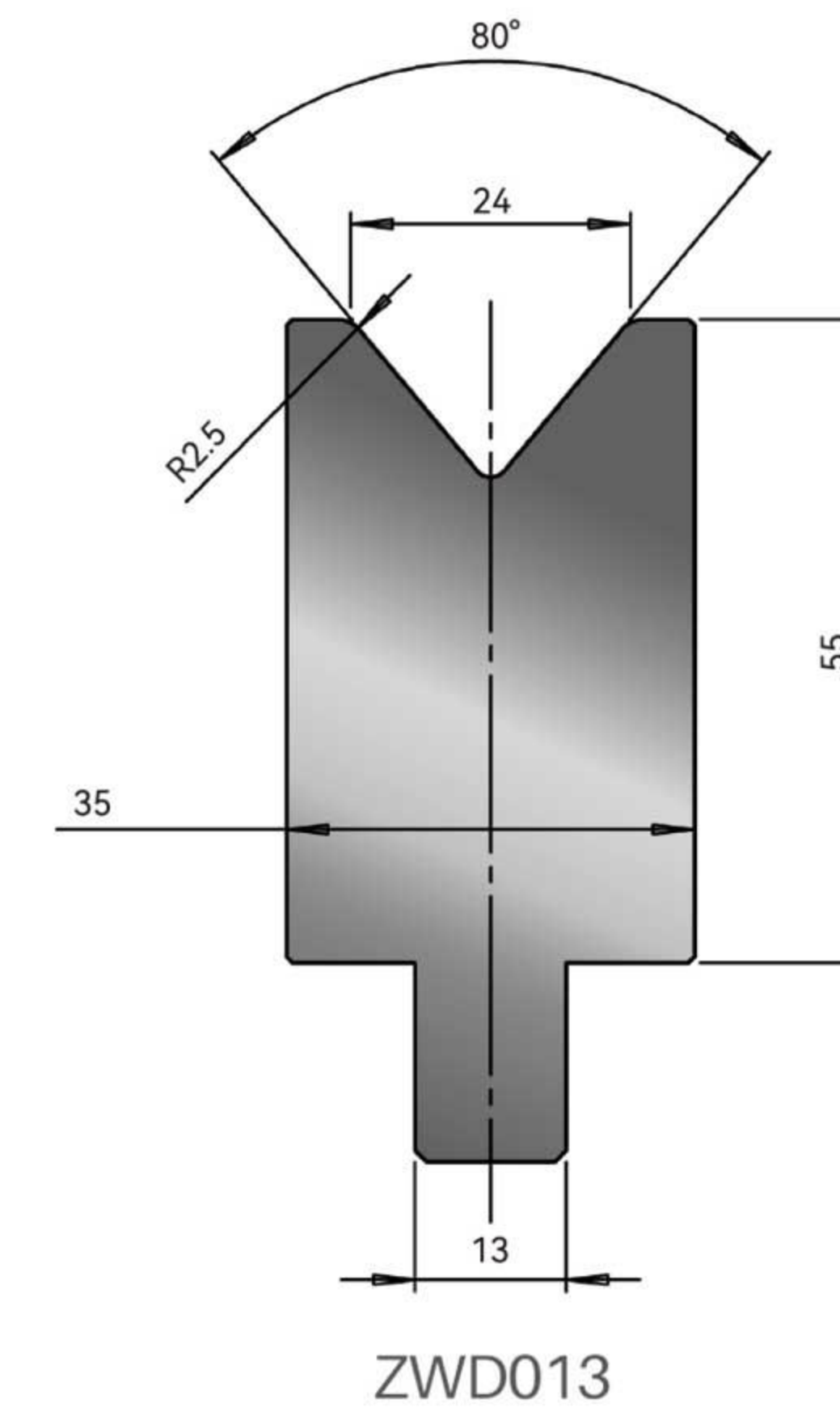

BENDMAX CAT.NO	WILA CAT.NO	Max Loading (t/m)	Weight (kg/m)
ZWD013	OZU-013	125	16
ZWD054	OZU-054	80	16
ZWD313	OZU-313	125	26.5
ZWD354	OZU-354	80	30



Die V=30mm

PRESSBRAKE TOOLS-BENDMAX-WILASTYLE

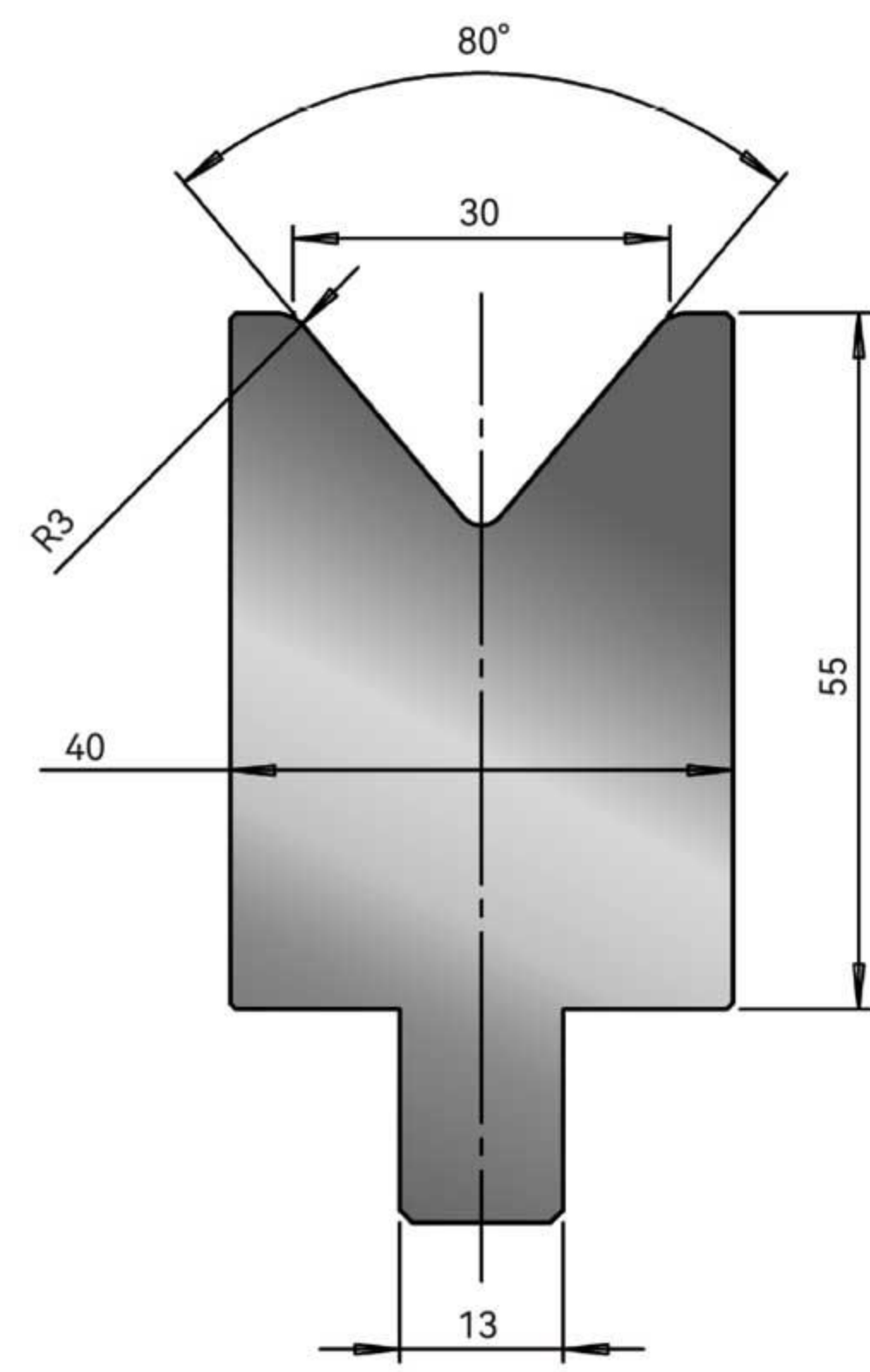

ZWD014

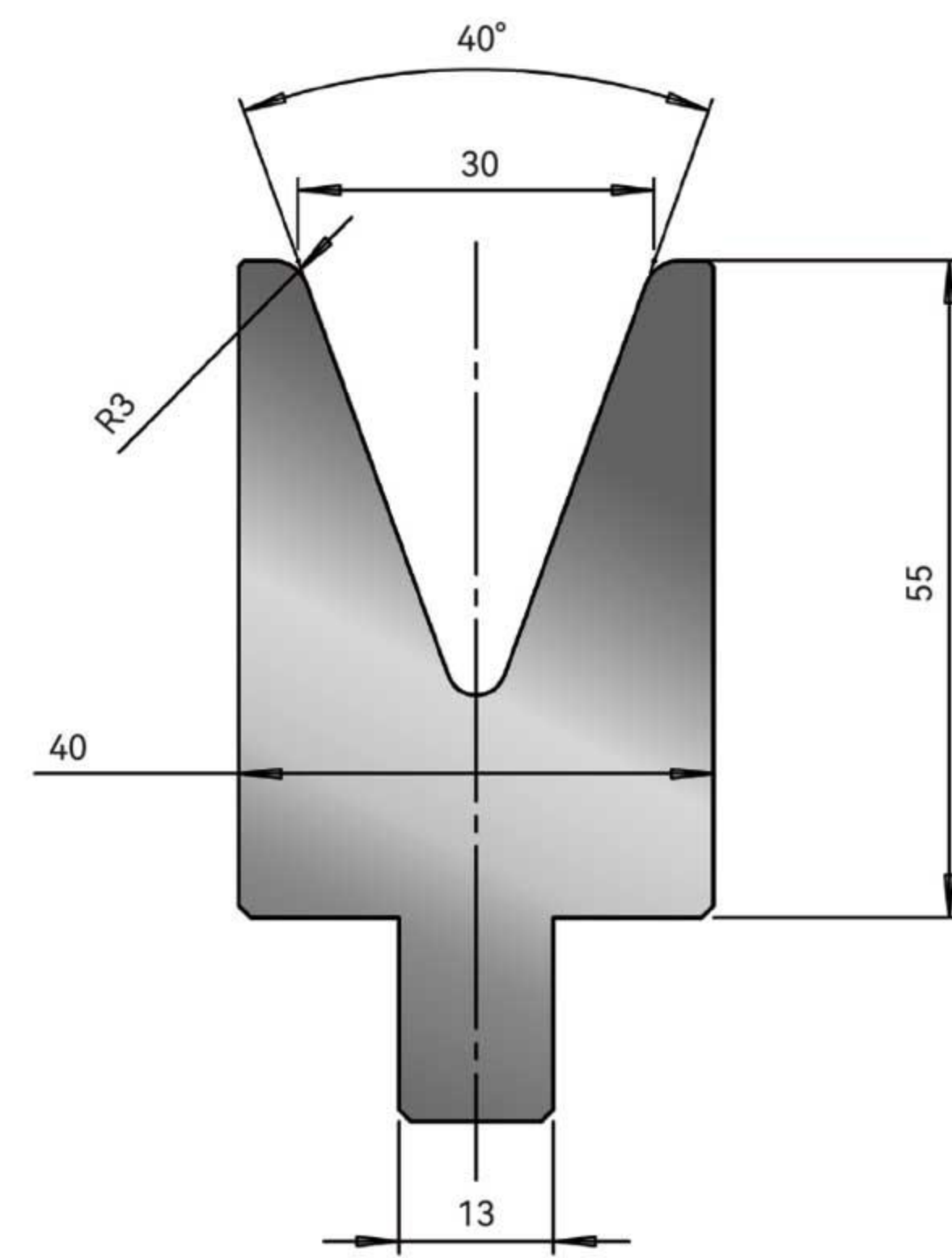

ZWD031

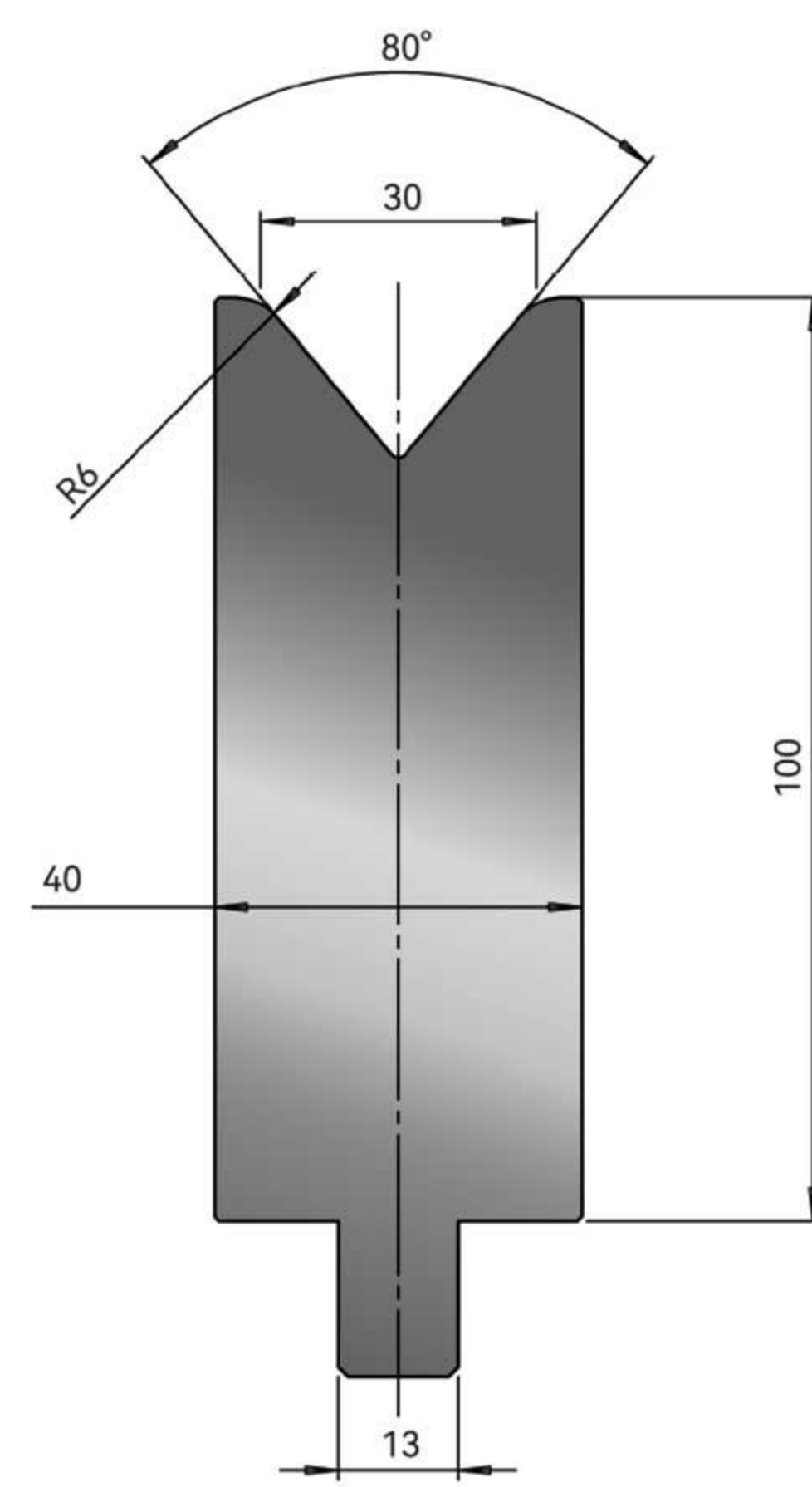

ZWD324

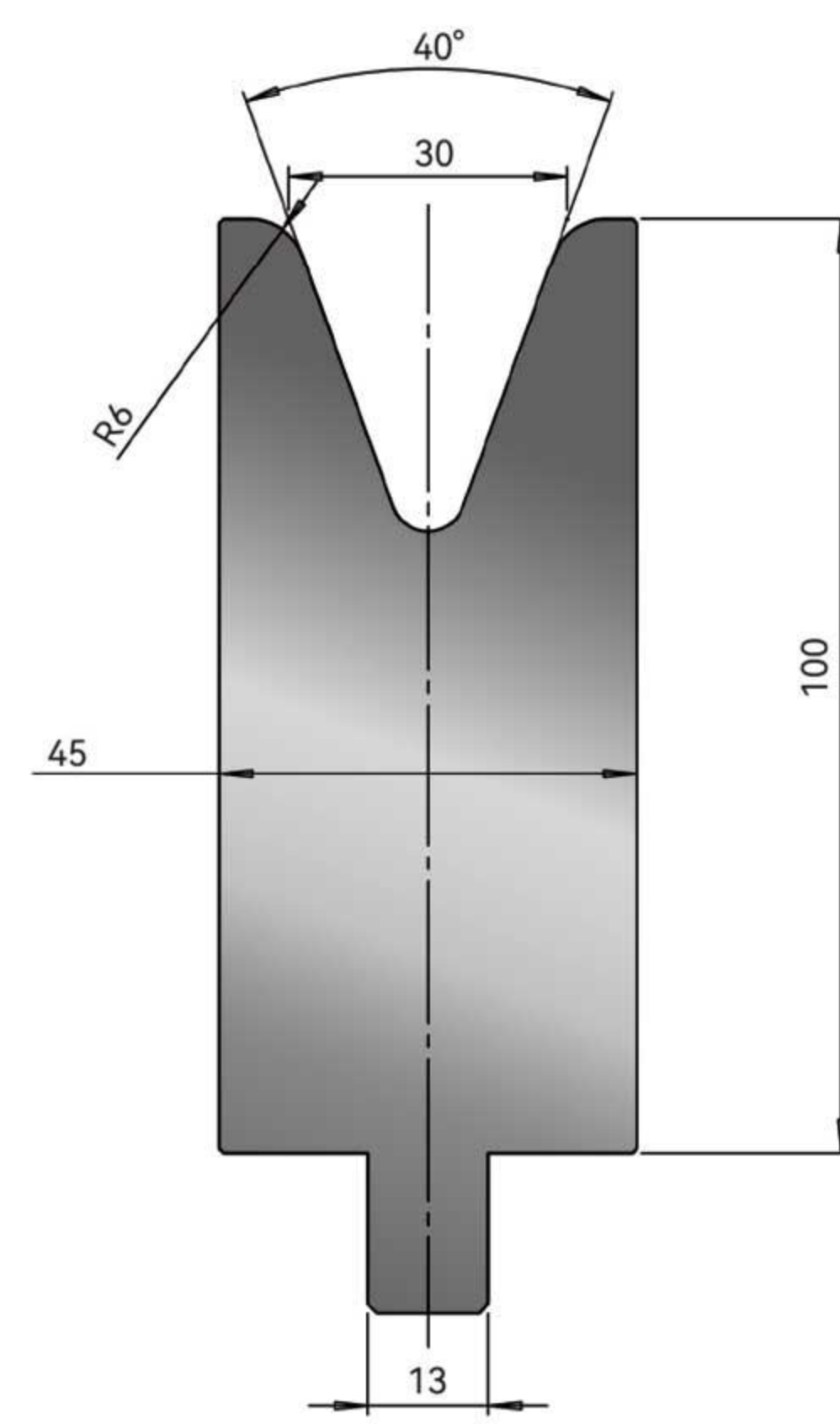

ZWD328

BENDMAX CAT.NO	WILA CAT.NO	Max Loading (t/m)	Weight (kg/m)
ZWD014	OZU-014	125	17
ZWD031	OZU-031	75	15
ZWD324	OZU-324	125	32
ZWD348	OZU-328	100	33



Die V=40mm

PRESSBRAKE TOOLS-BENDMAX-WILASTYLE

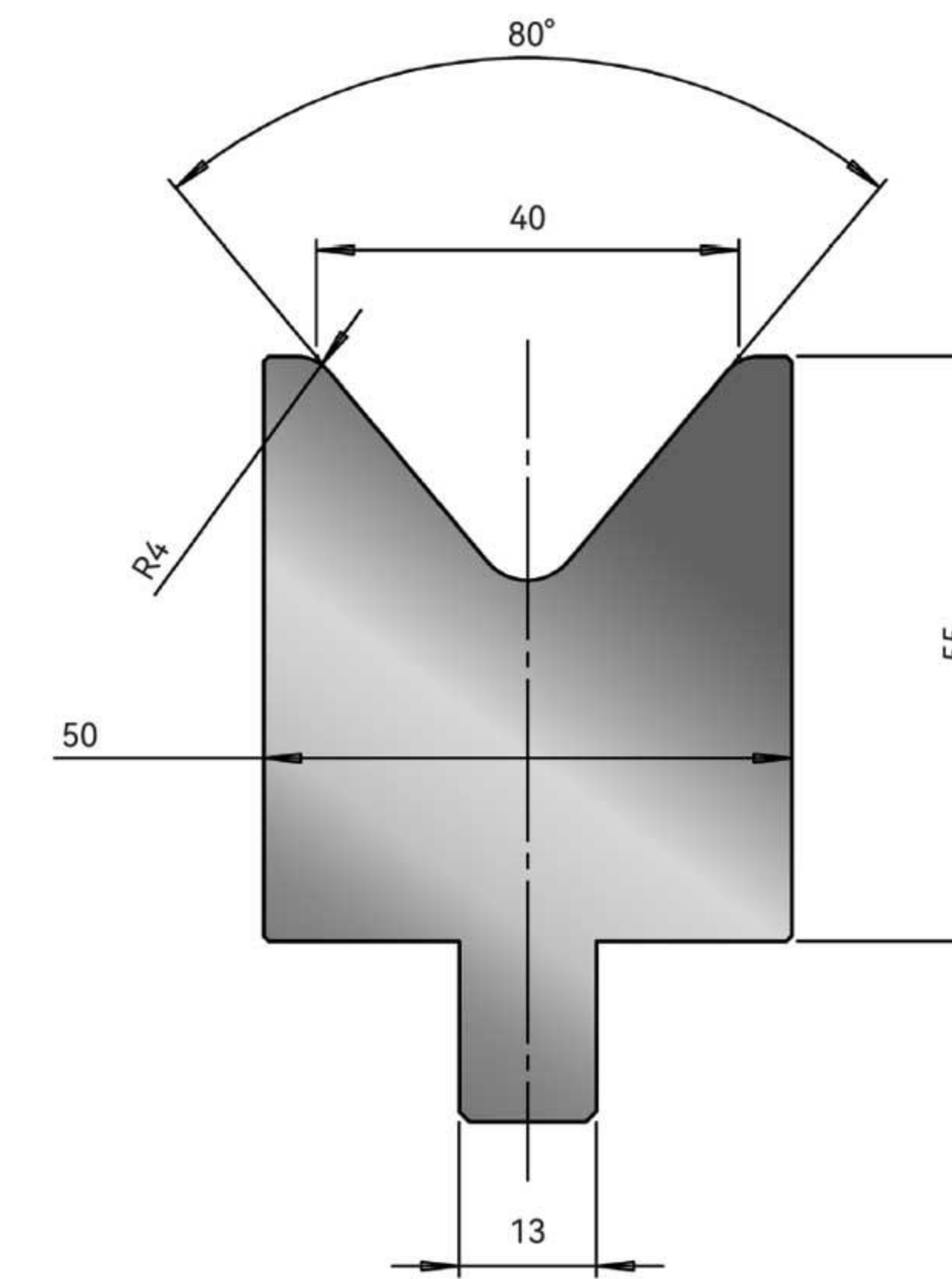

ZWD015

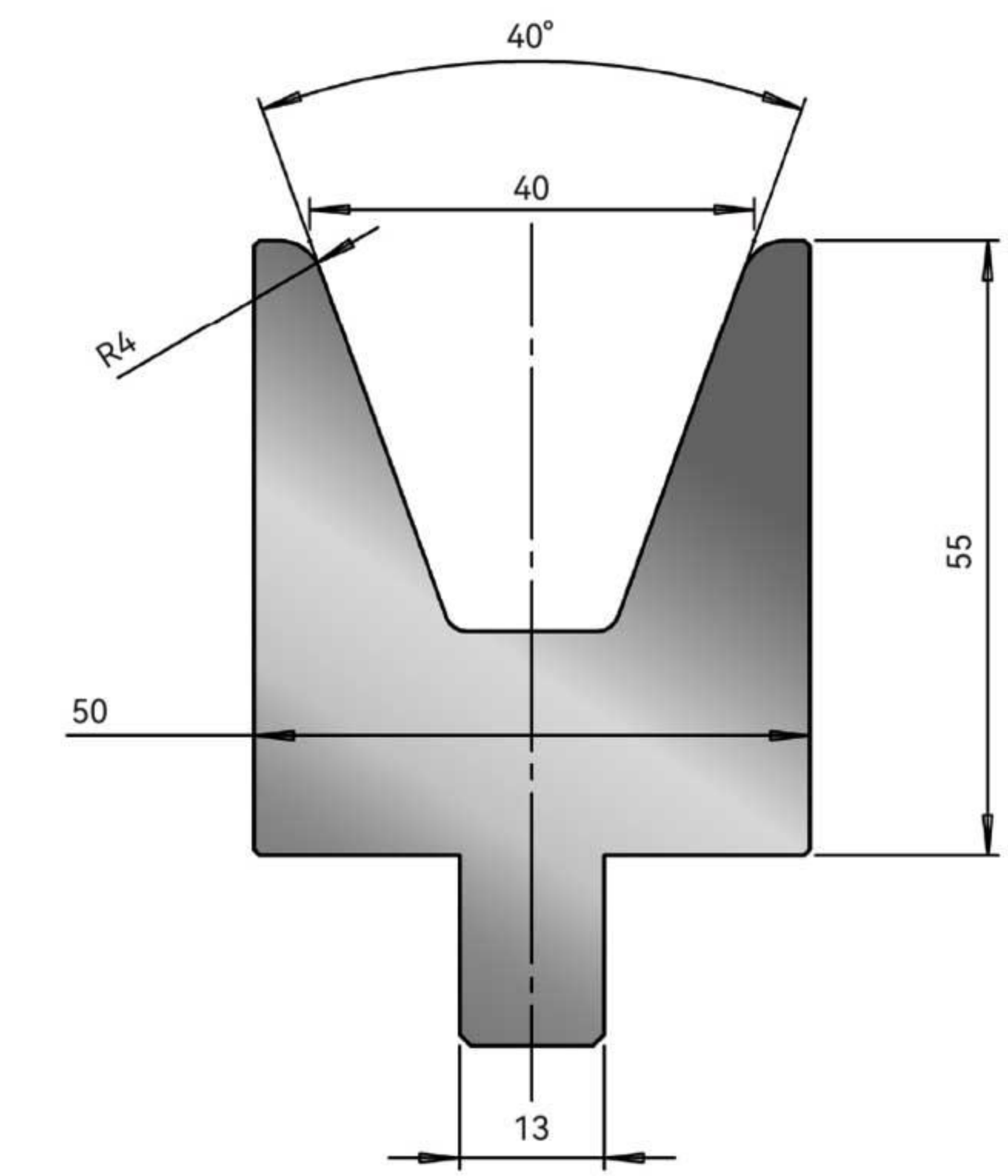

ZWD032

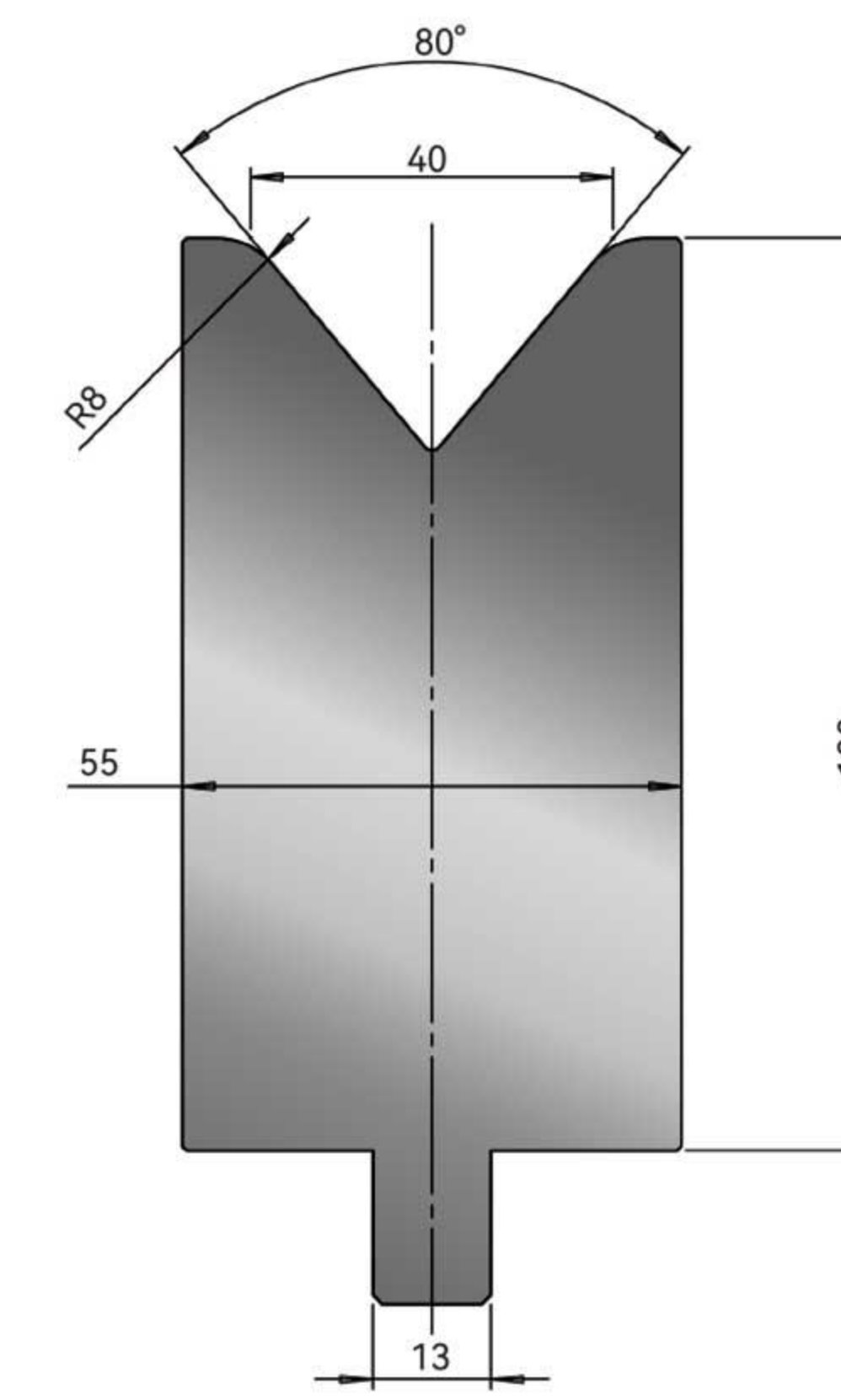

ZWD325

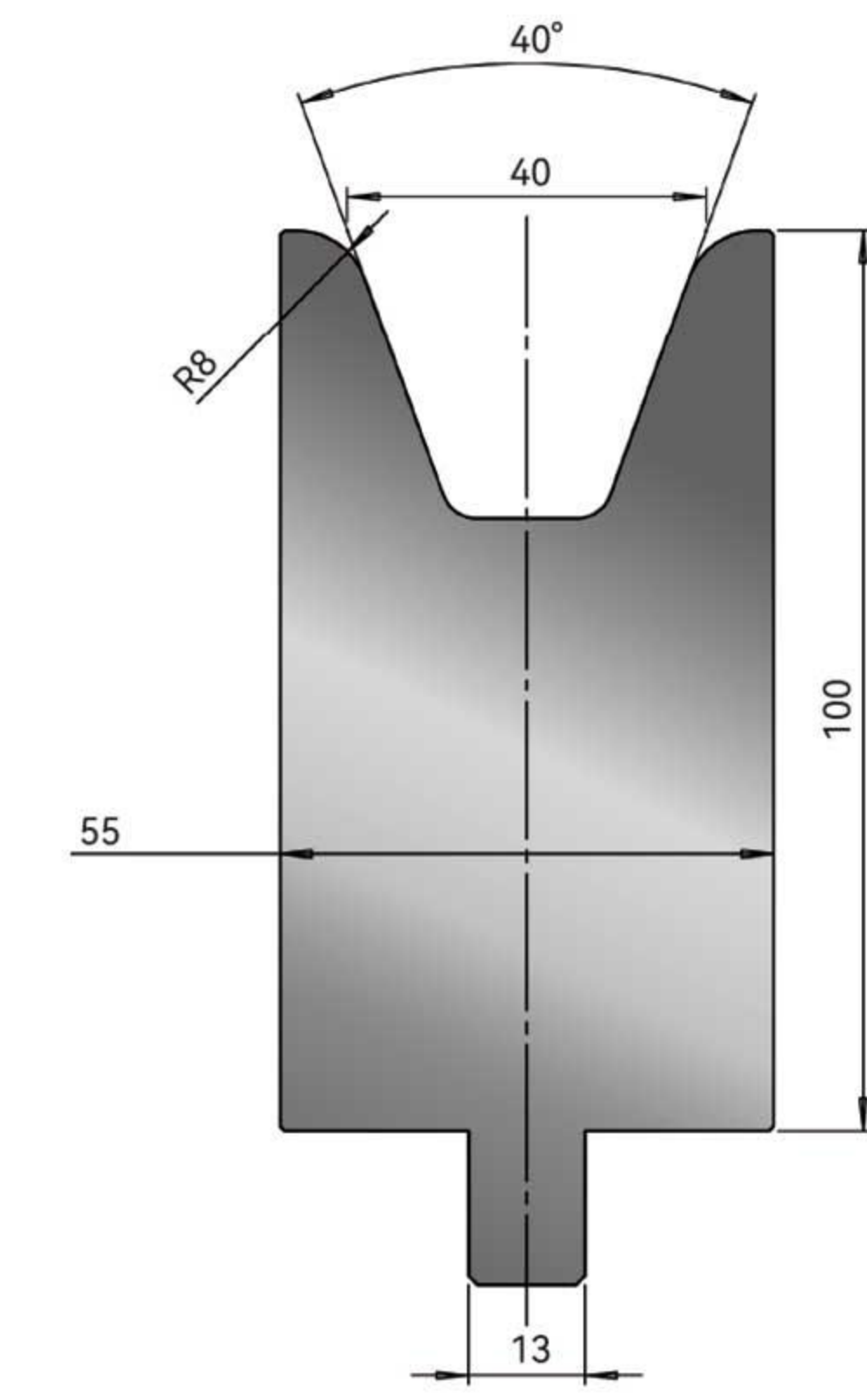

ZWD329

BENDMAX CAT.NO	WILA CAT.NO	Max Loading (t/m)	Weight (kg/m)
ZWD015	OZU-015	125	16
ZWD032	OZU-032	80	16
ZWD325	OZU-325	125	26.5
ZWD329	OZU-329	125	30



Die V=50mm

PRESSBRAKE TOOLS-BENDMAX-WILASTYLE



Die V=60mm

PRESSBRAKE TOOLS-BENDMAX-WILASTYLE

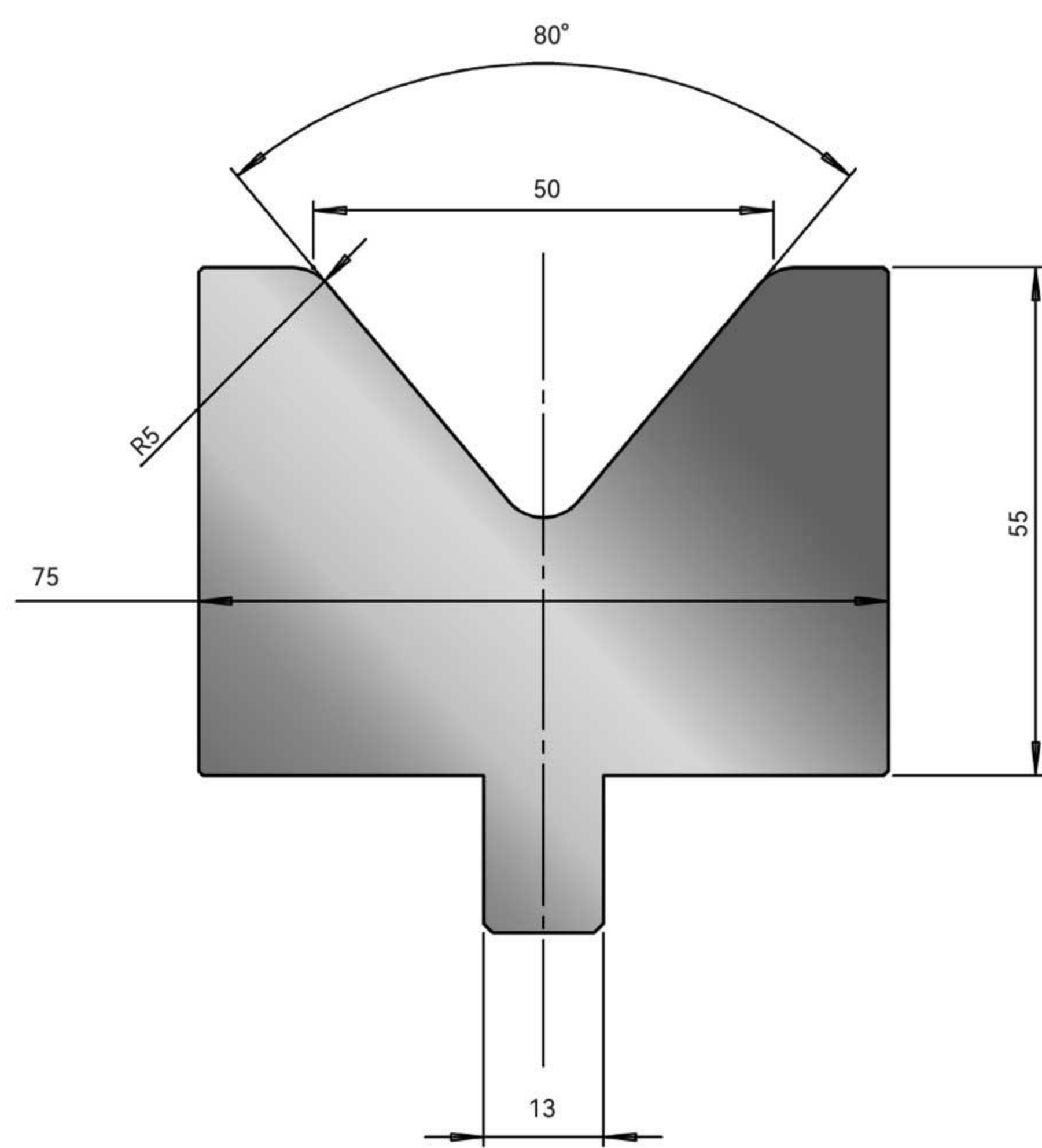

ZWD035

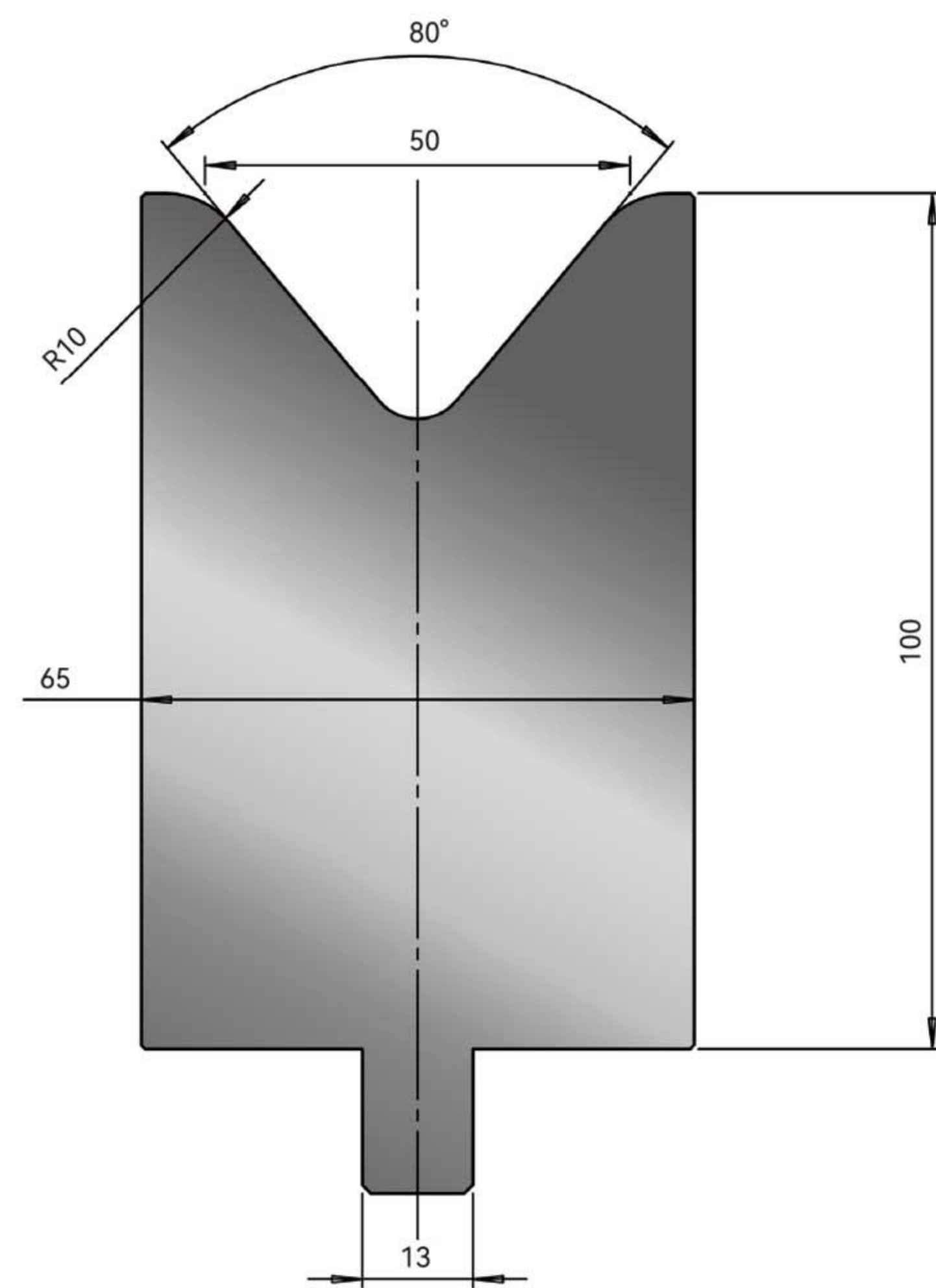

ZWD326

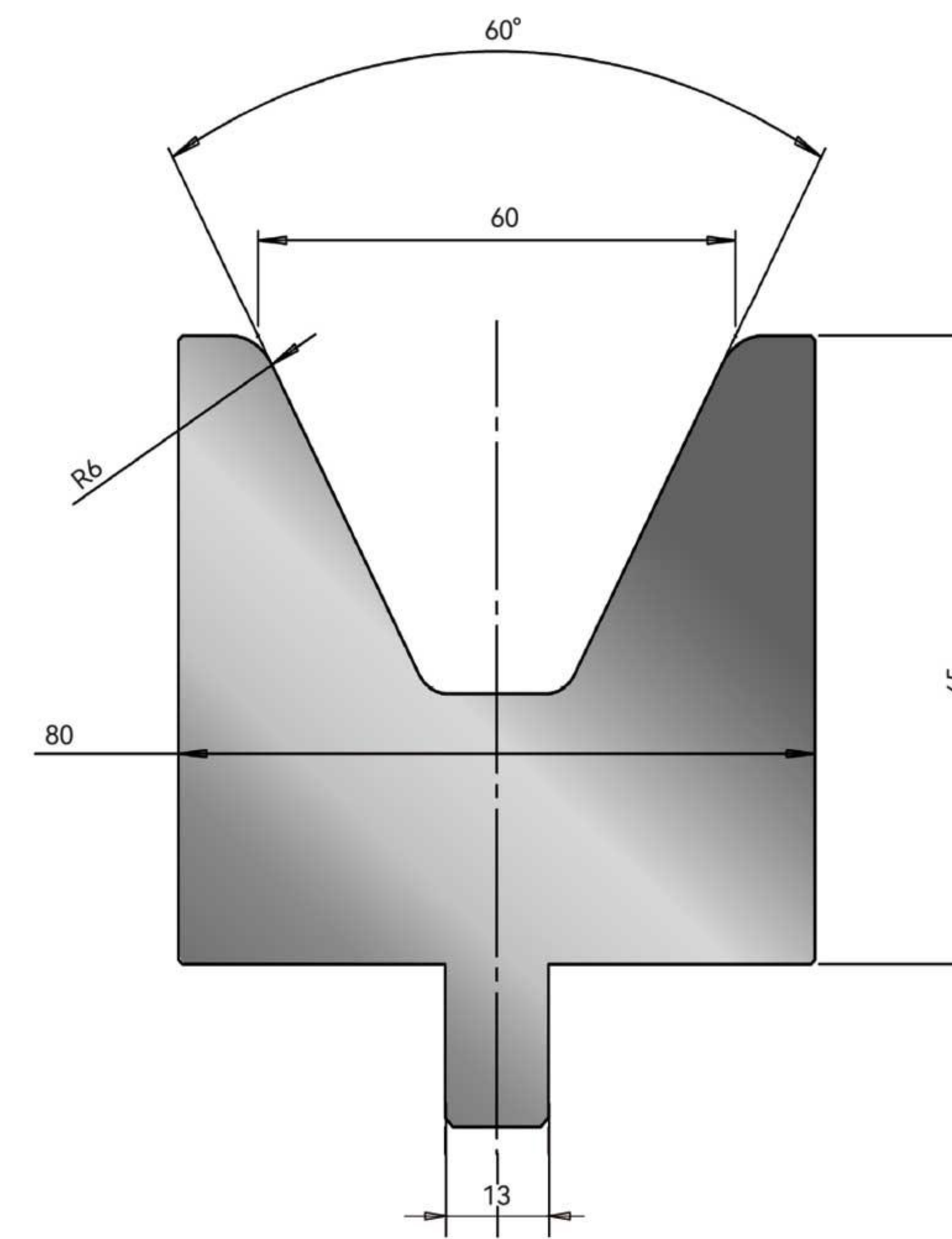

ZWD016

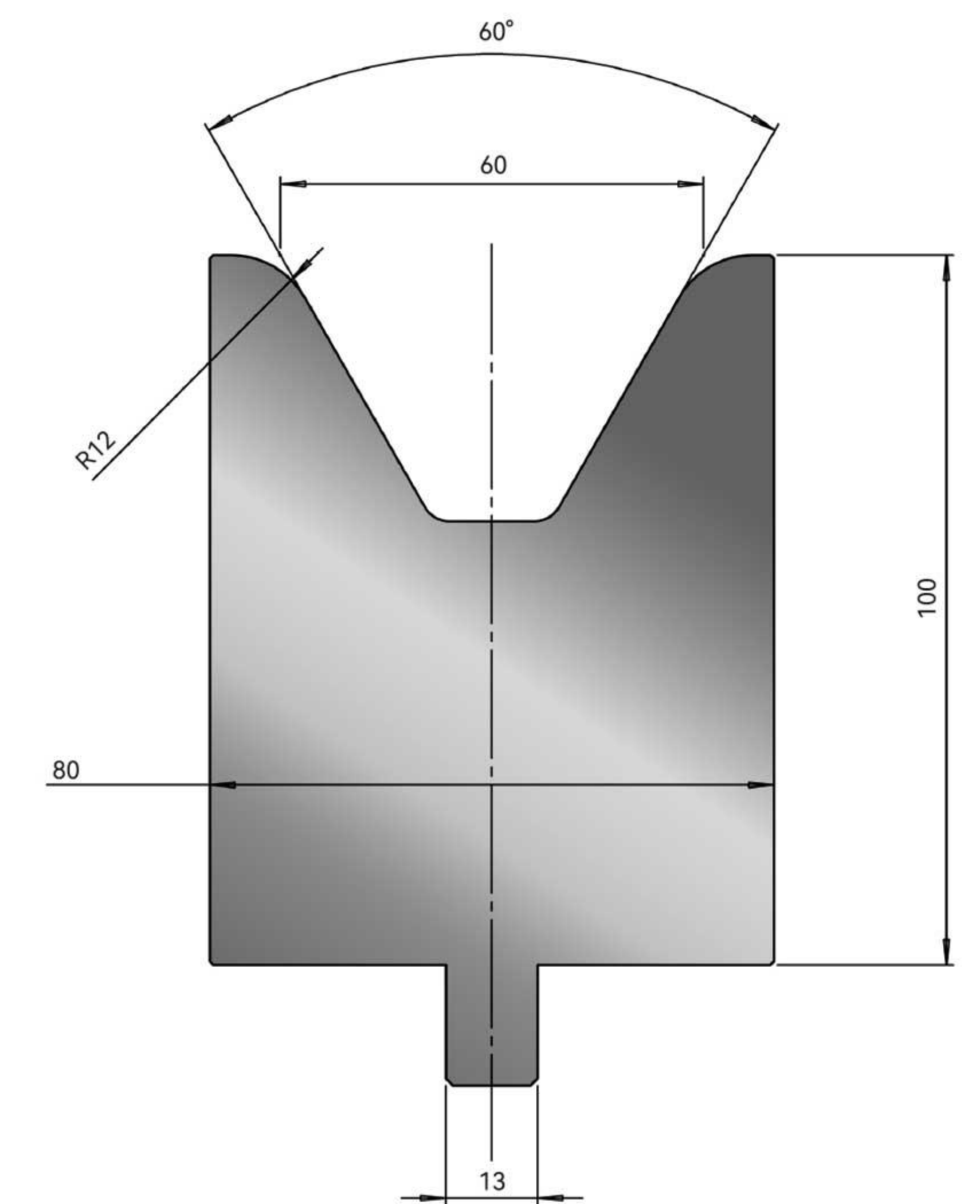

ZWD327

BENDMAX CAT.NO	WILA CAT.NO	Max Loading (t/m)	Weight (kg/m)
ZWD035	OZU-035	150	29
ZWD326	OZU-326	150	48

BENDMAX CAT.NO	WILA CAT.NO	Max Loading (t/m)	Weight (kg/m)
ZWD016	OZU-016	160	32
ZWD327	OZU-327	160	54



FLATTENING TOOLS V6

PRESSBRAKE TOOLS-BENDMAX-WILASTYLE

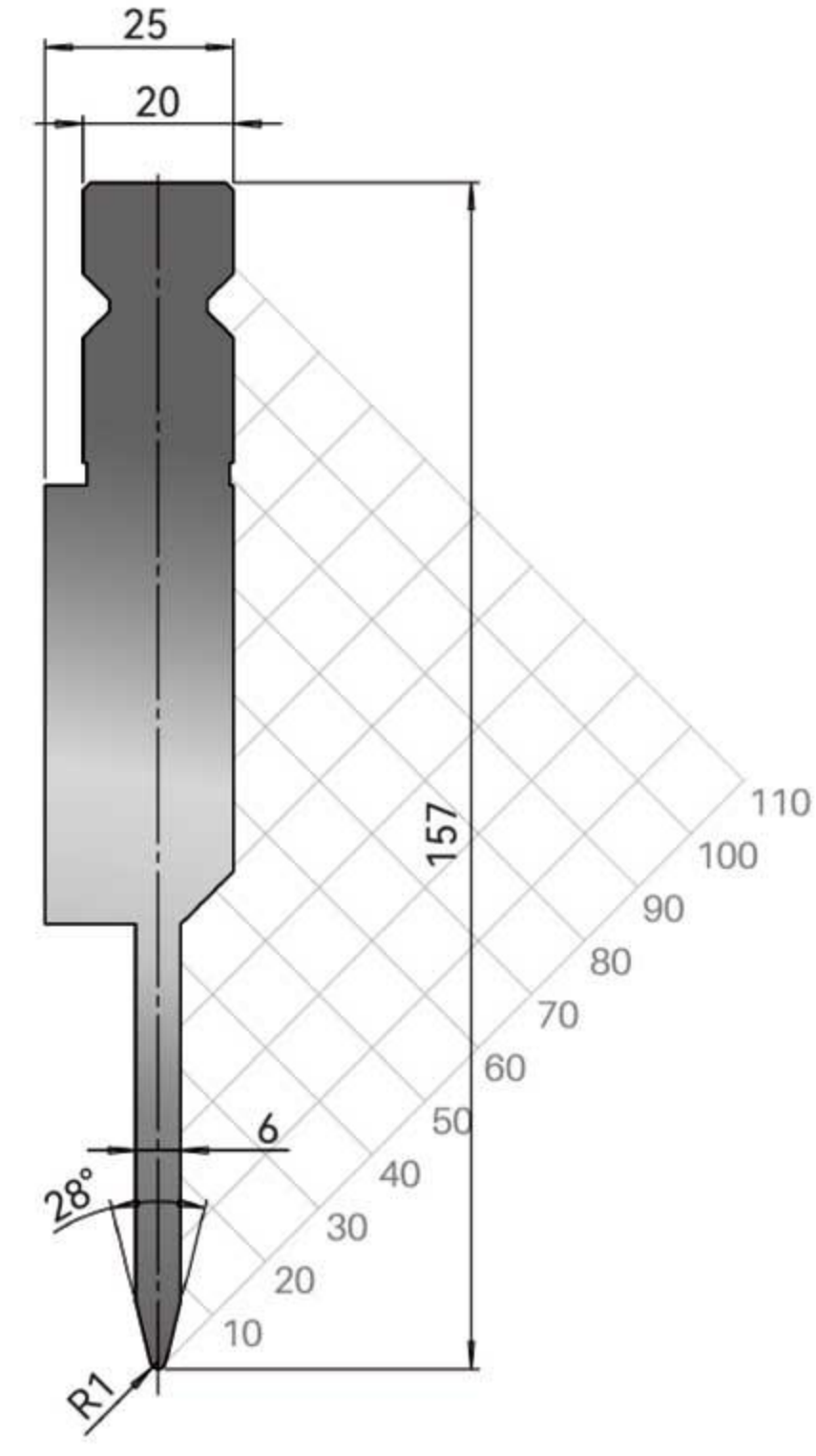

ZWP061

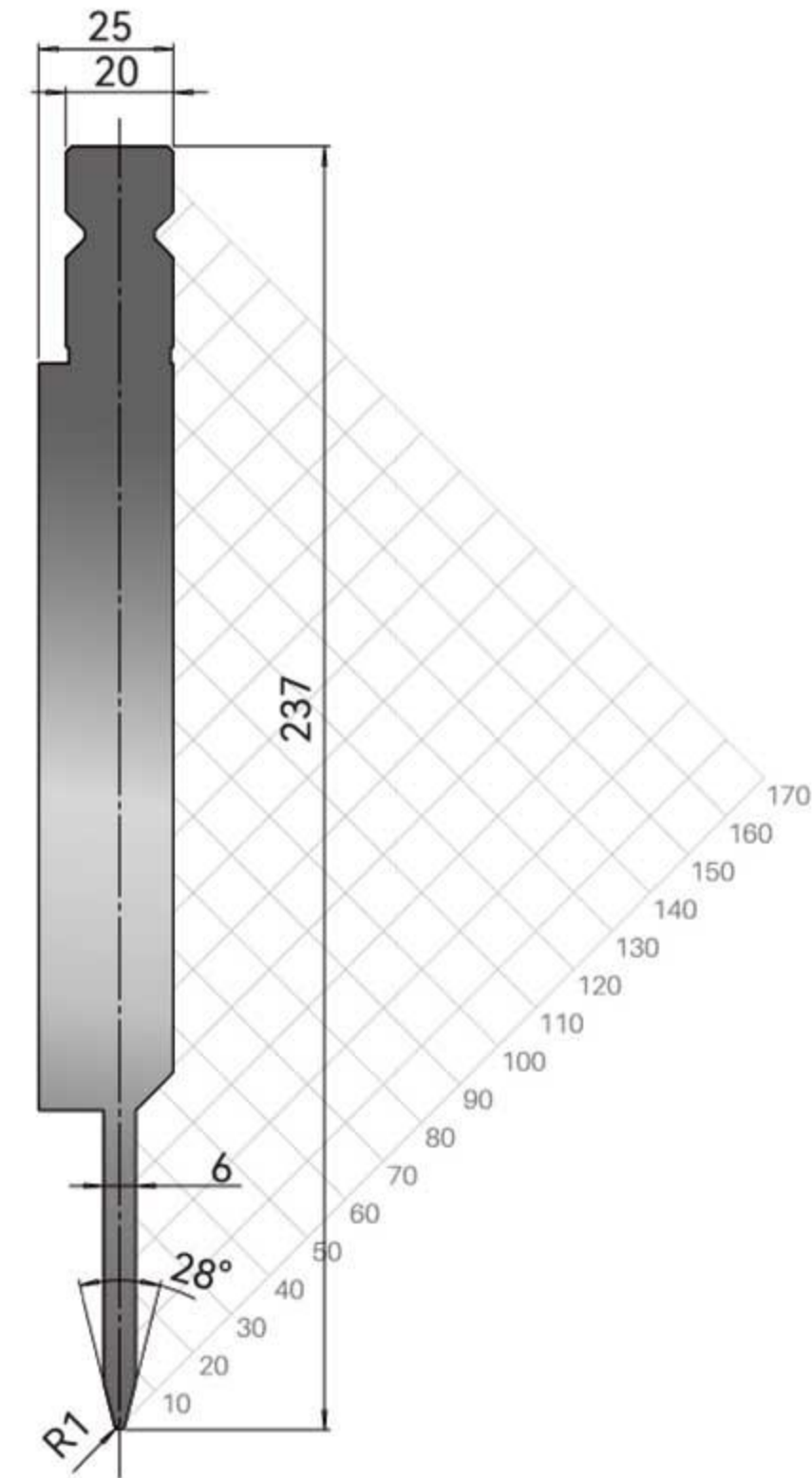

ZWP063

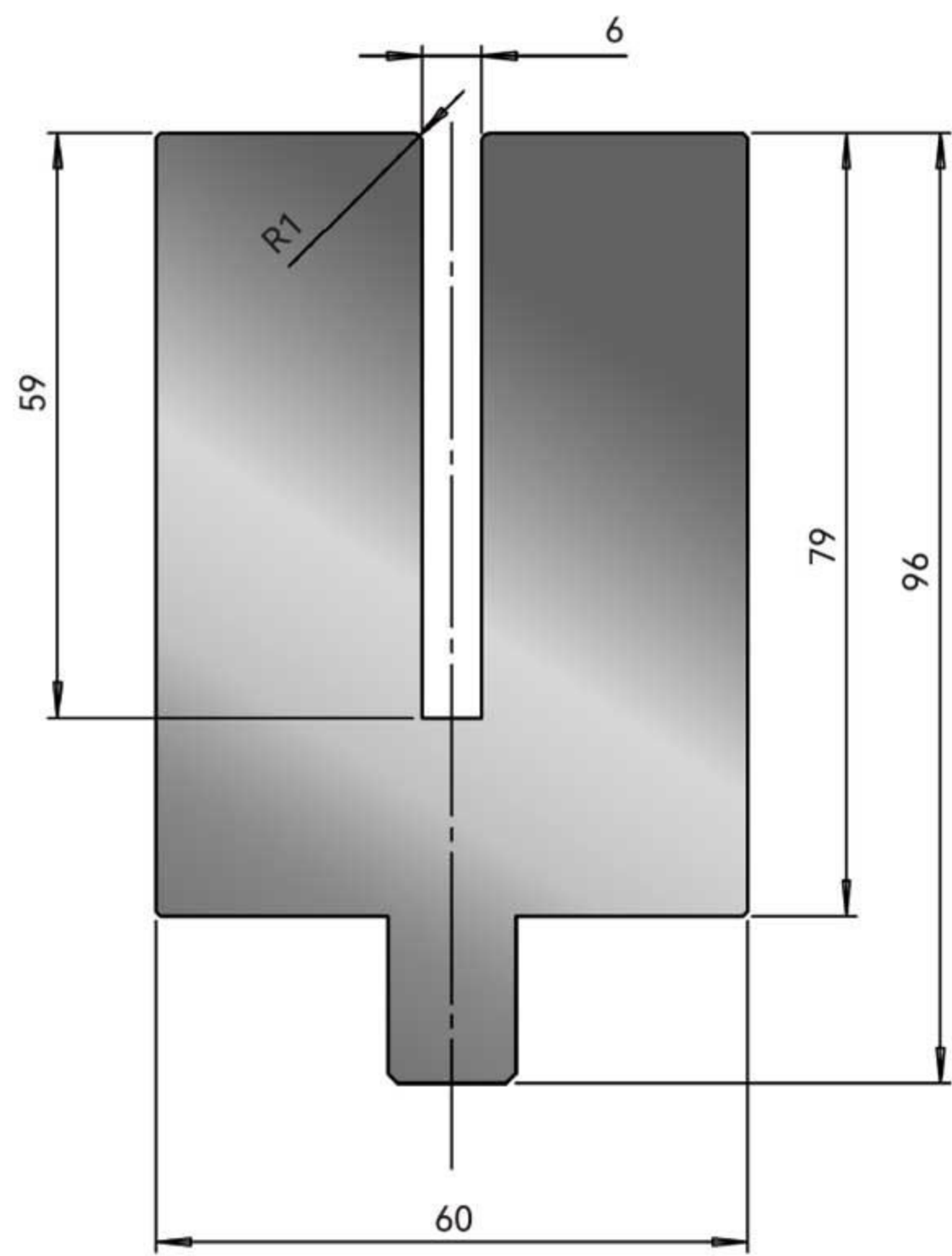

ZWD082

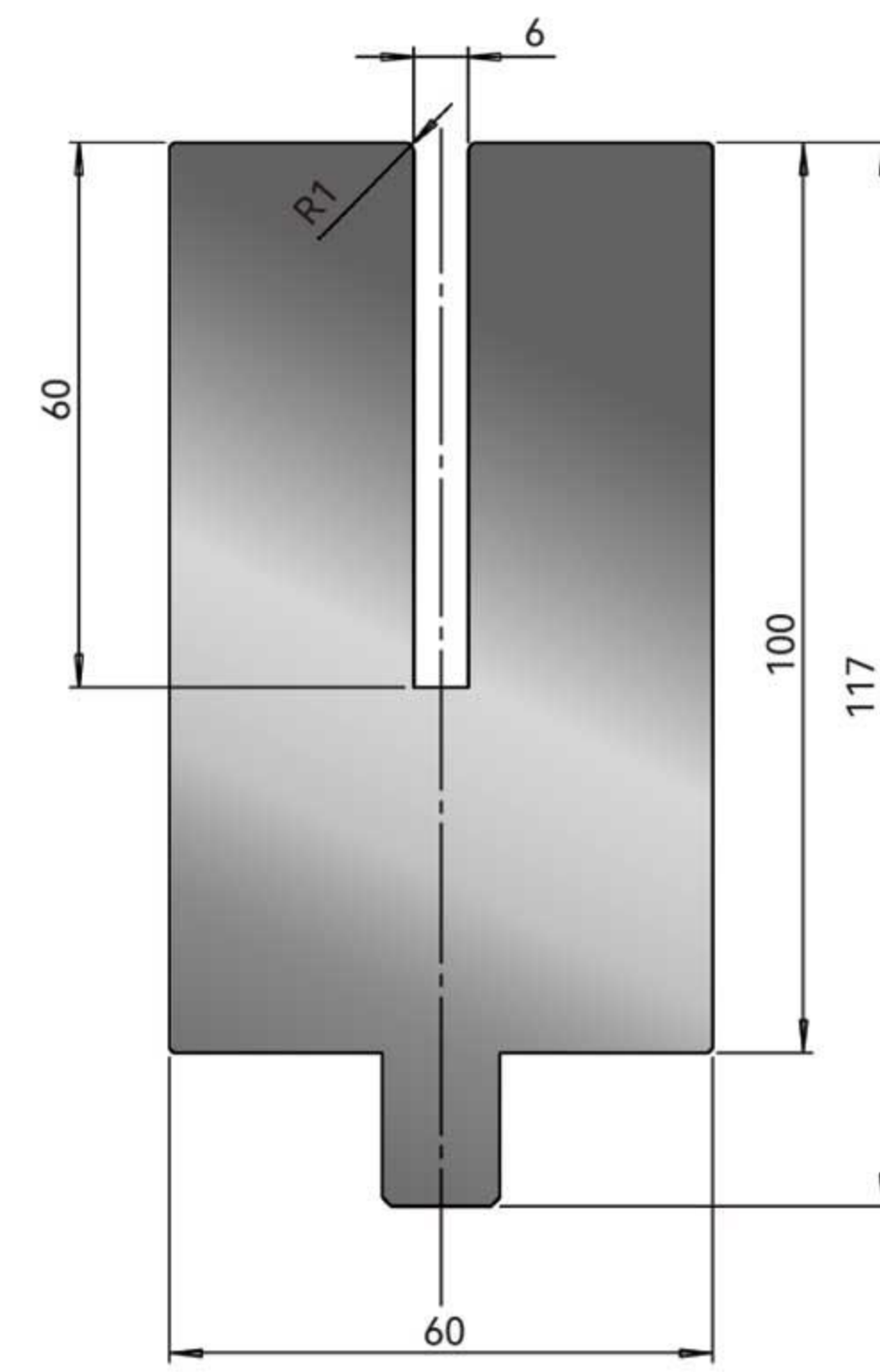

ZWD382



FLATTENING TOOLS V10

PRESSBRAKE TOOLS-BENDMAX-WILASTYLE

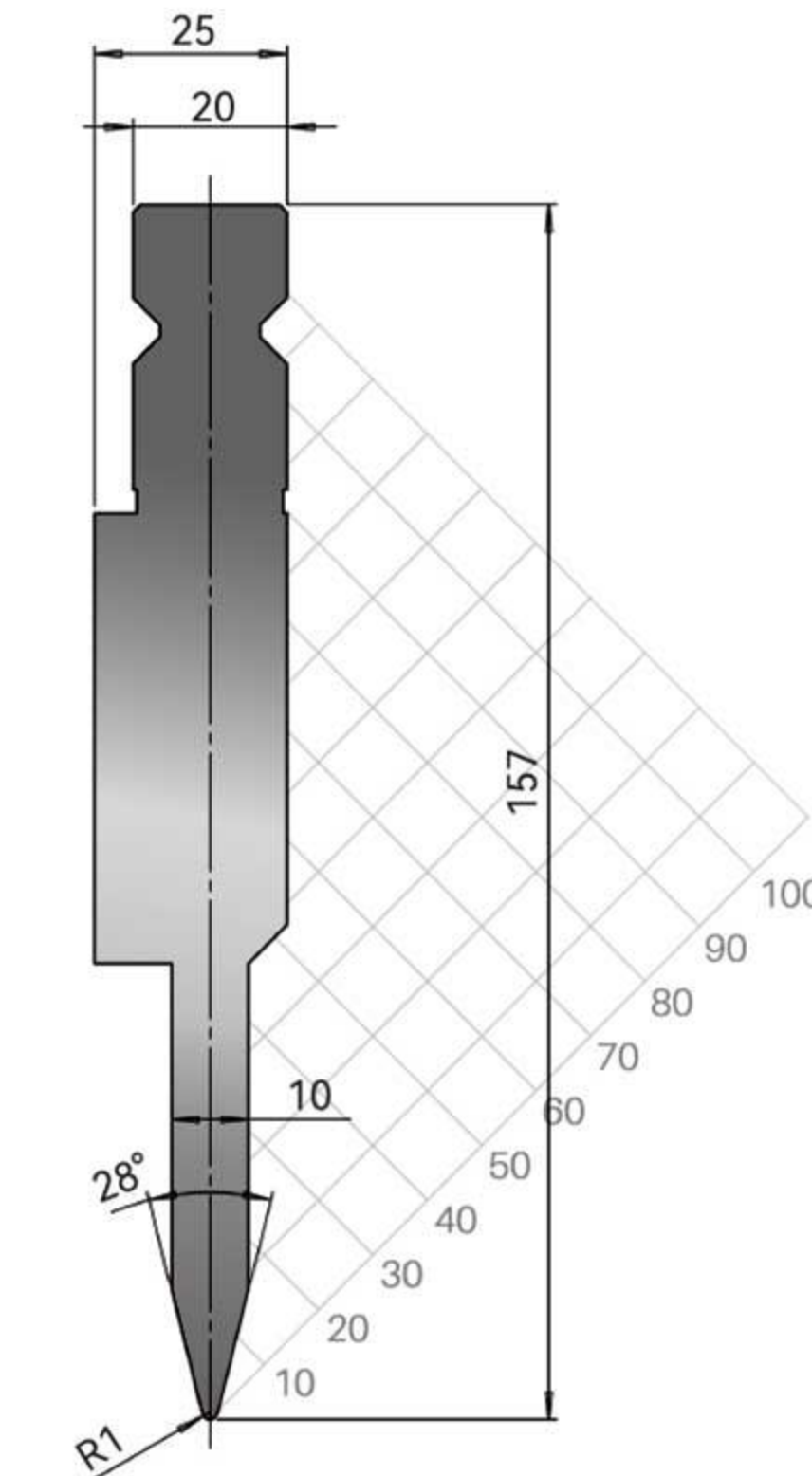

ZWP051

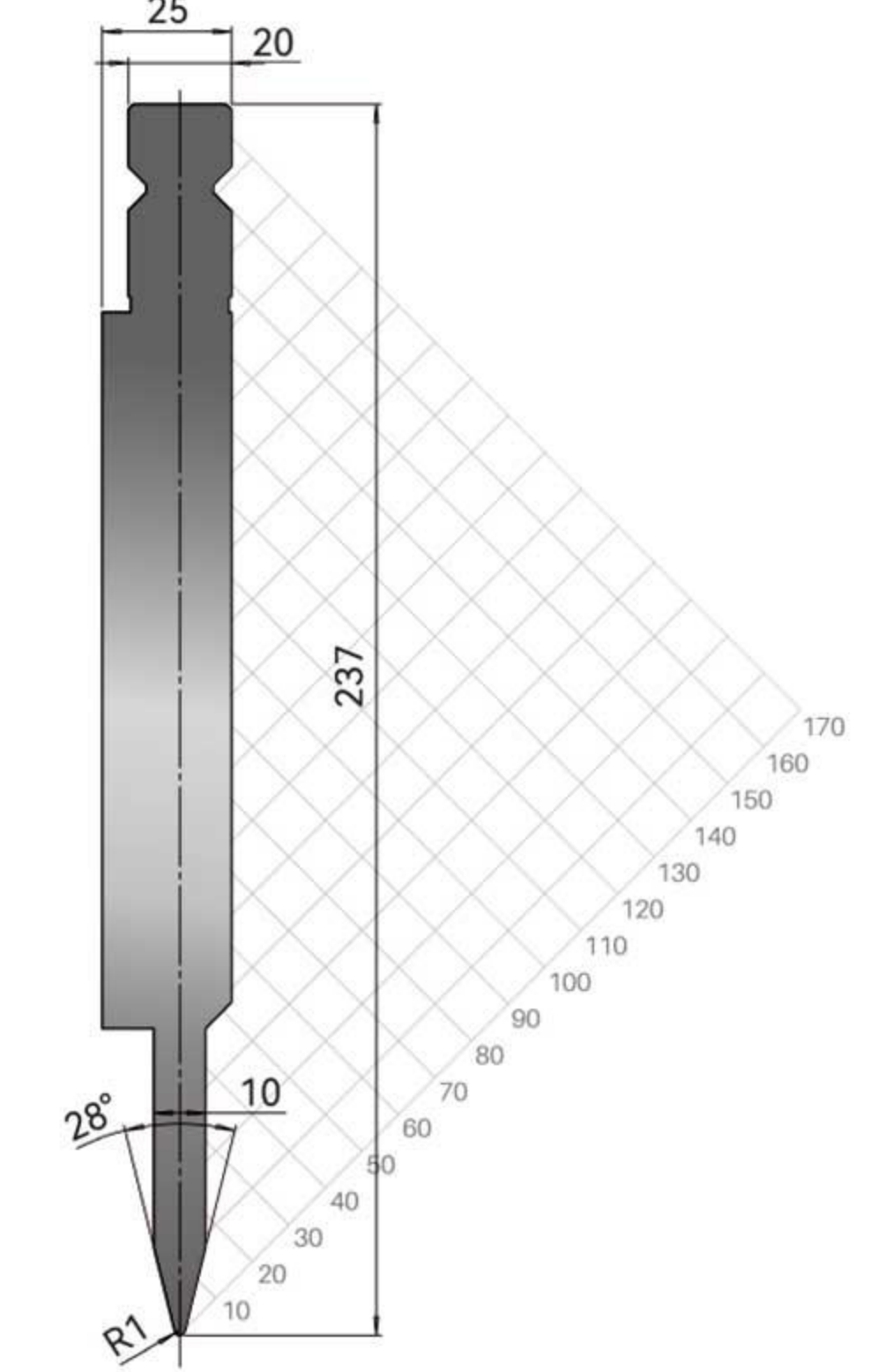

ZWP053

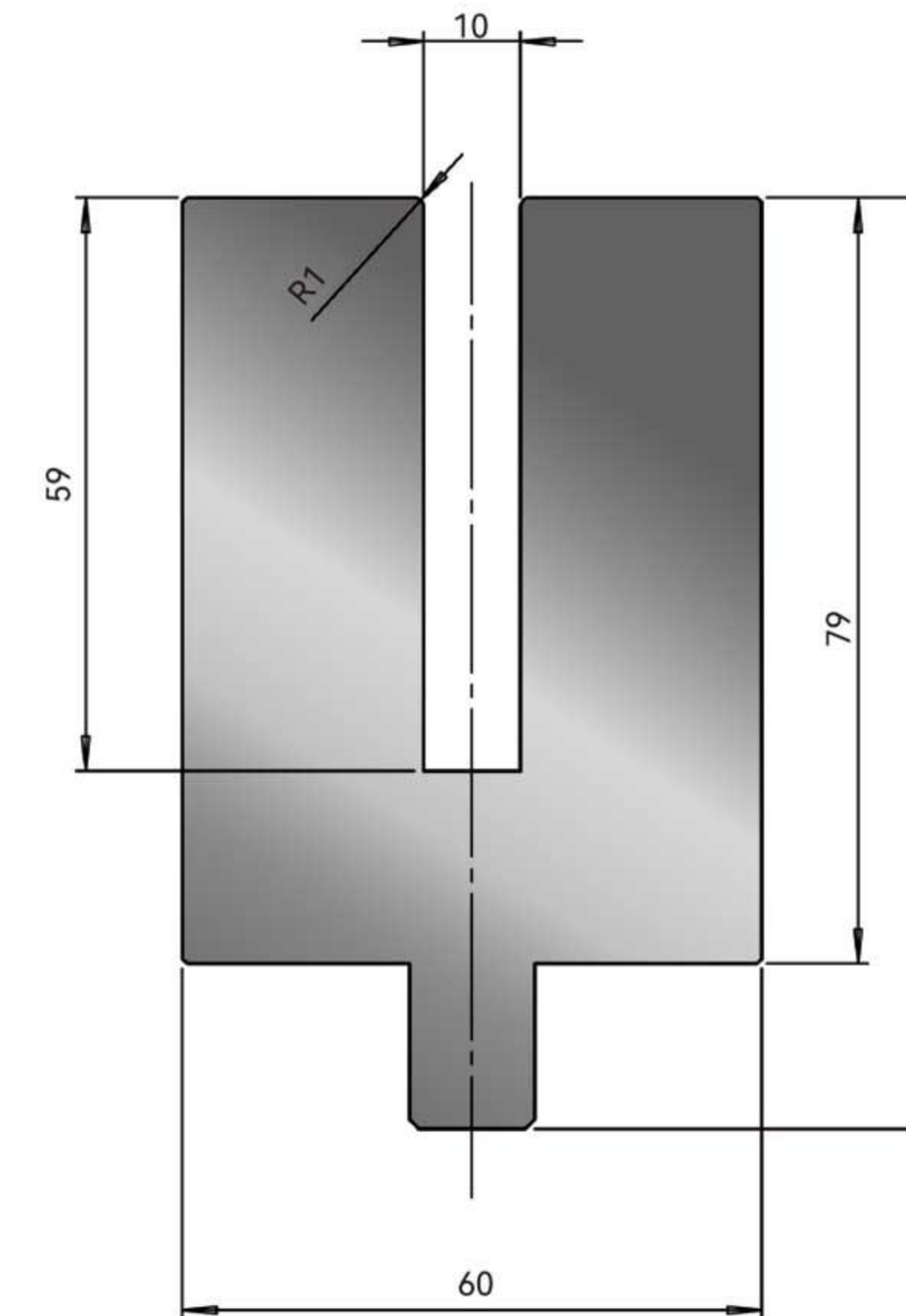

ZWD083

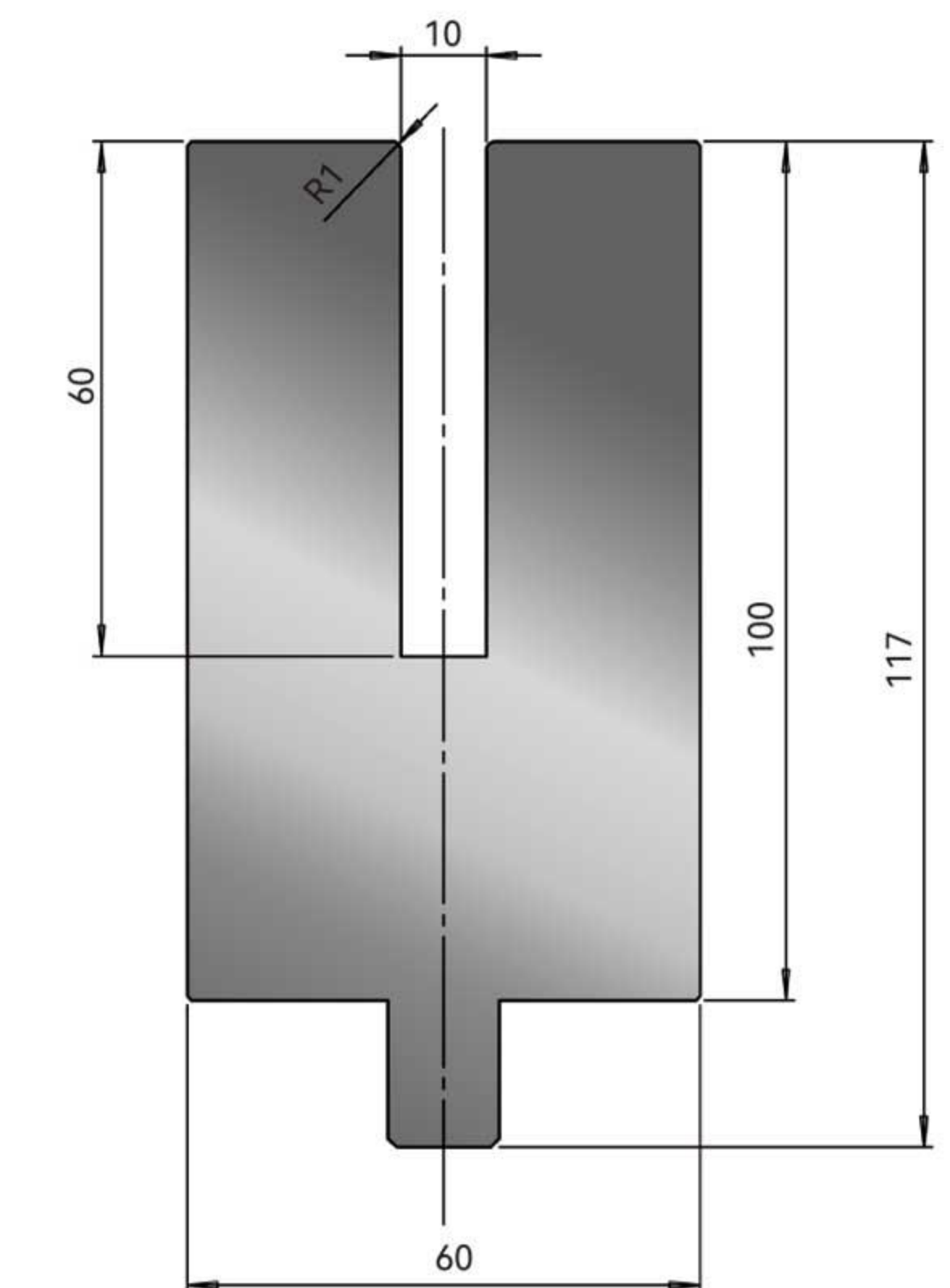

ZWD381

BENDMAX CAT.NO	WILA CAT.NO	Max Loading (t/m)	Weight (kg/m)
ZWP061	BIU-061	50	20
ZWP063	BIU-063	50	38
ZWD082	OZU-082	100	36
ZWD382	OZU-382	100	45

BENDMAX CAT.NO	WILA CAT.NO	Max Loading (t/m)	Weight (kg/m)
ZWP051	BIU-051	100	22
ZWP053	BIU-053	100	38
ZWD083	OZU-083	100	35
ZWD381	OZU-381	100	44.5



Offset Z Tools

PRESSBRAKE TOOLS-BENDMAX-WILASTYLE

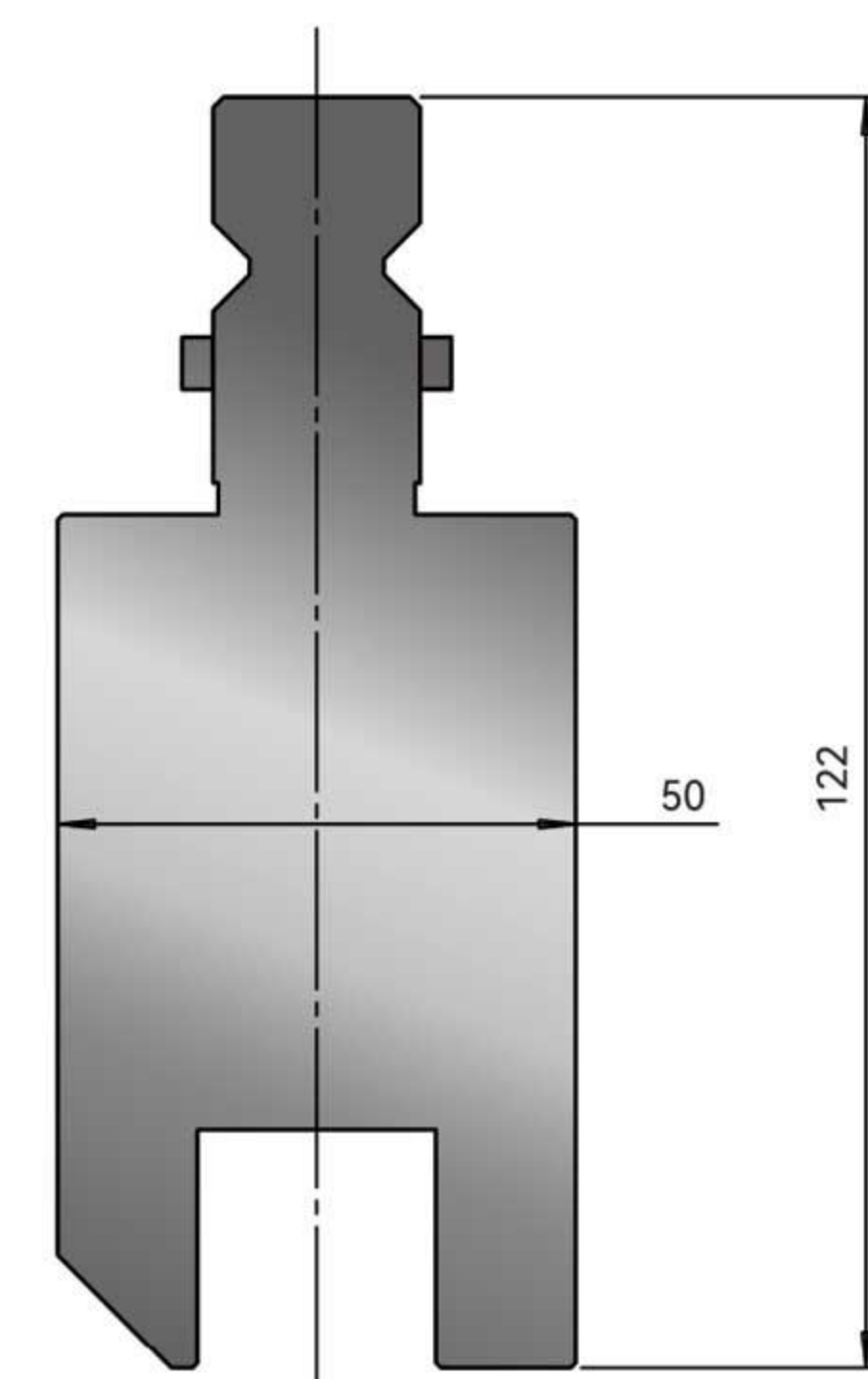

ZWZPH001

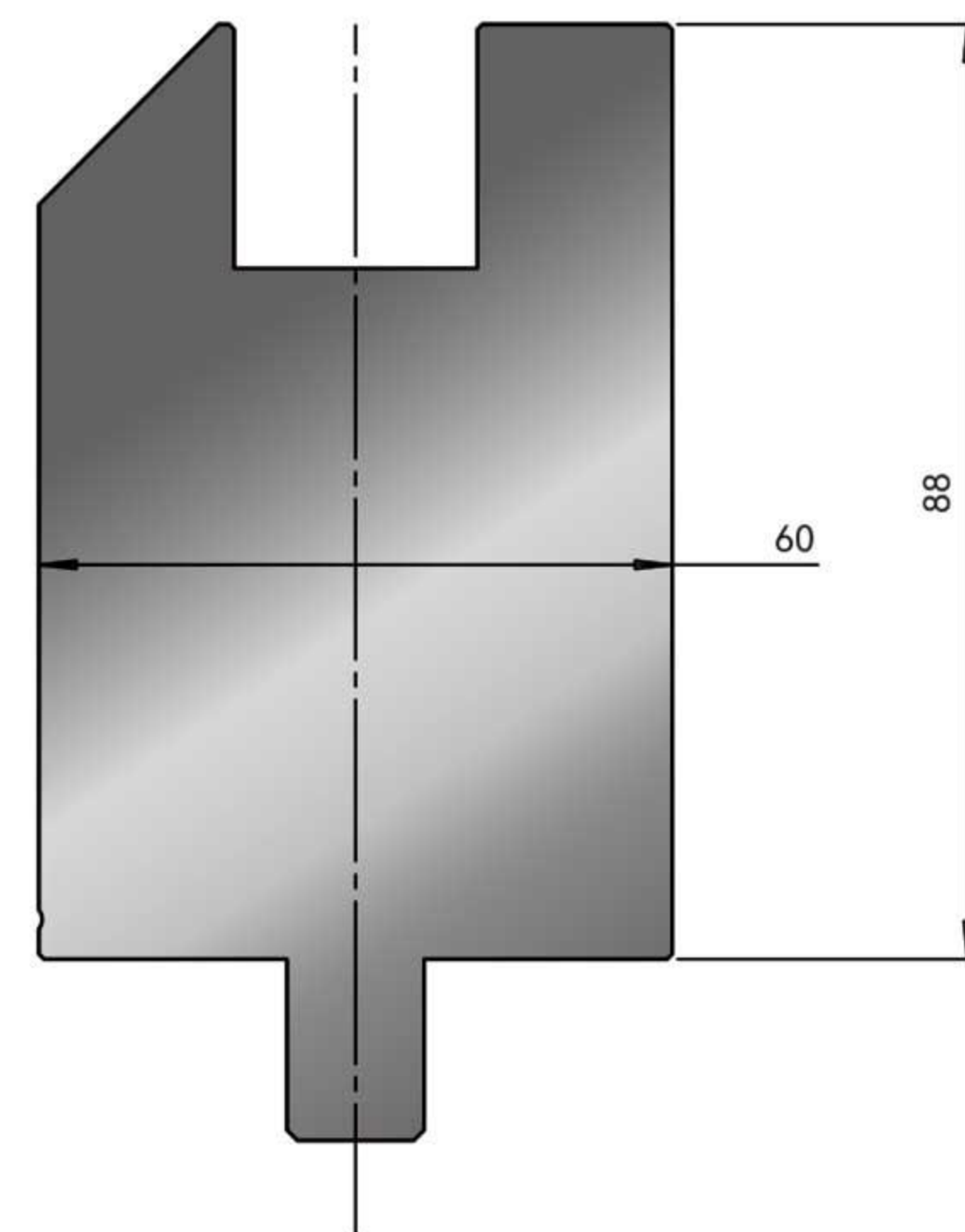

ZWZDH006

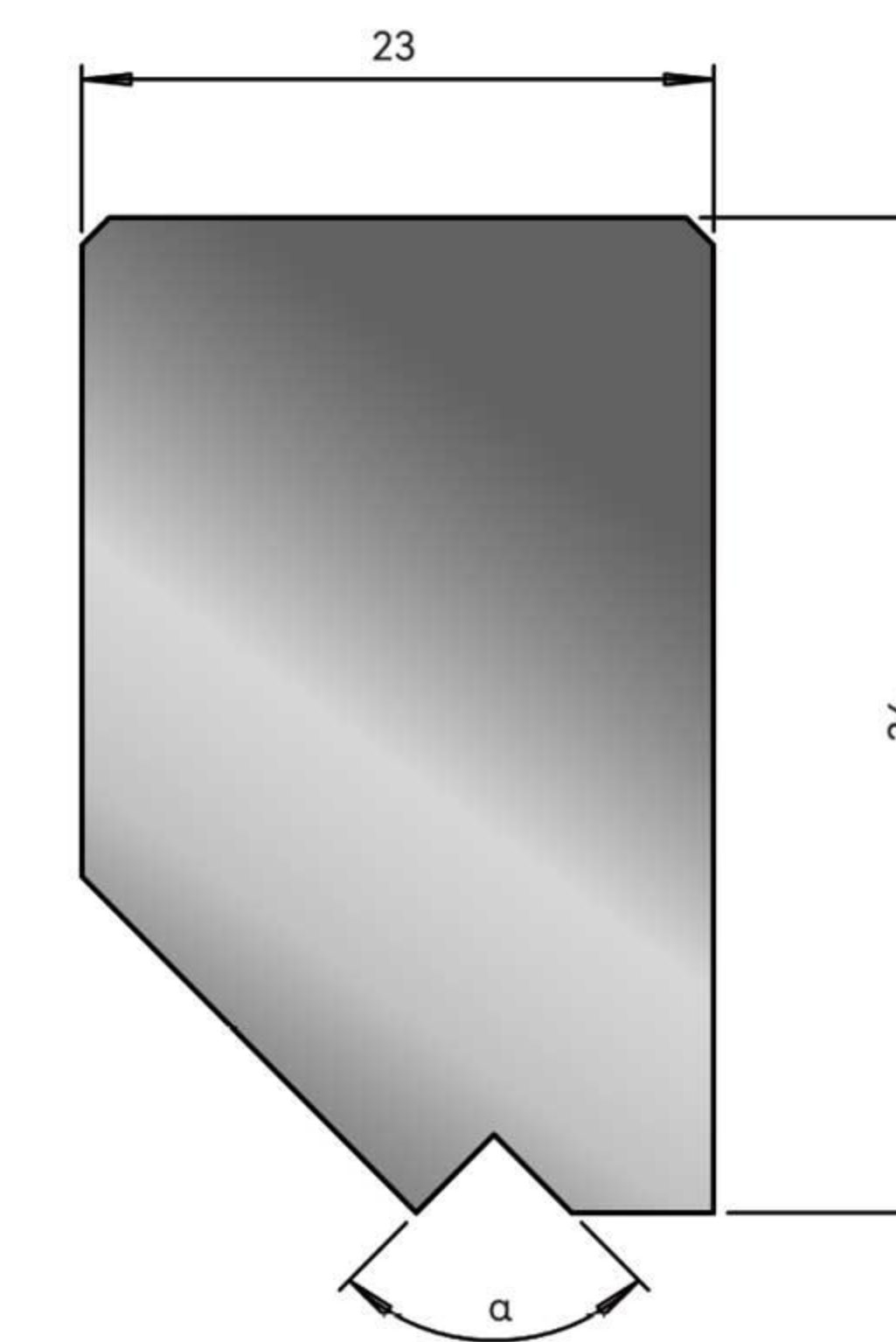

ZWZIN002

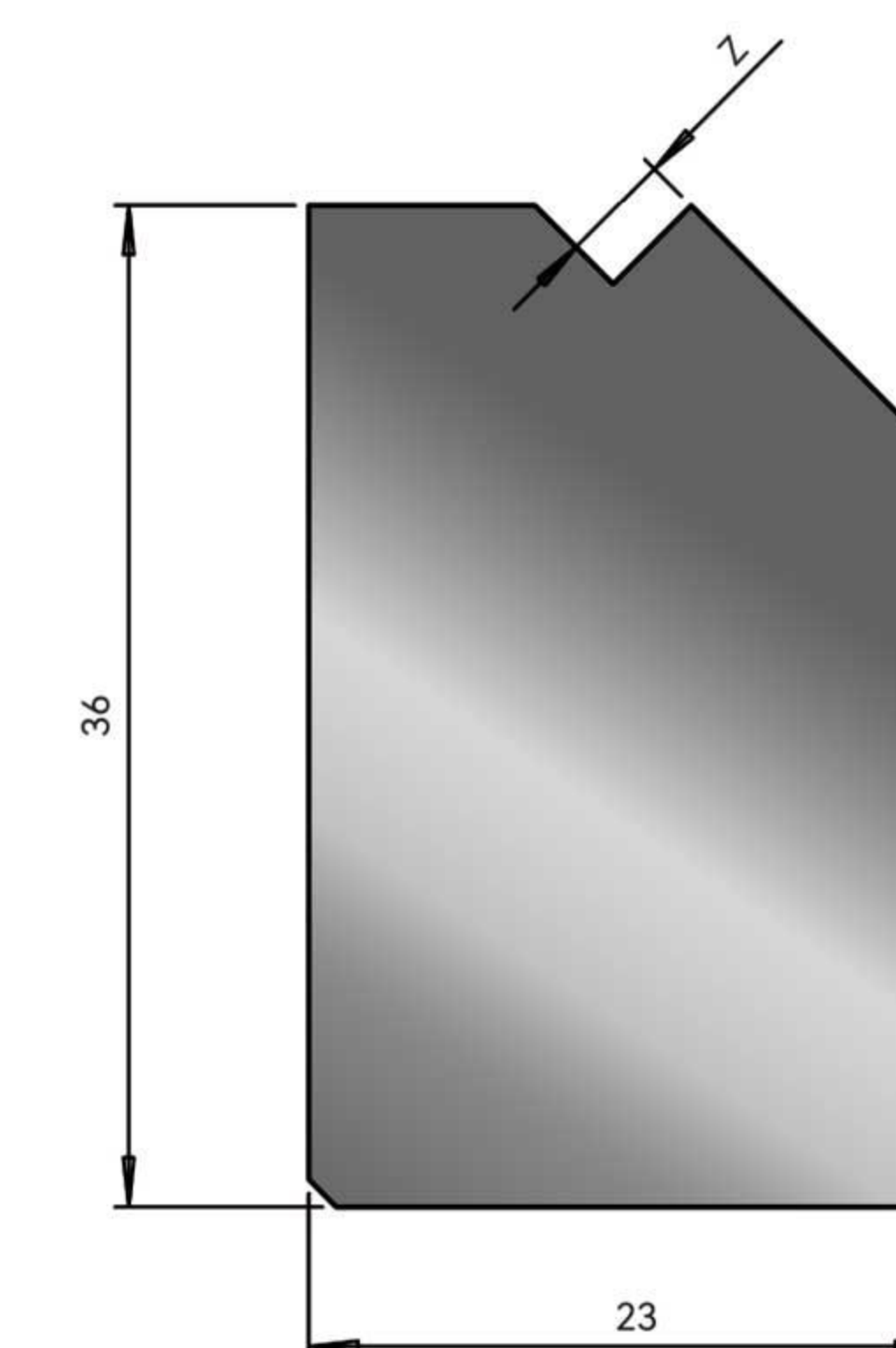

ZWZIN002

BENDMAX CAT.NO	WILA CAT.NO	LENGTH	Max Loading (t/m)	Weight (kg/m)
ZWZPH001	HU001	515	100	17.5
ZWZDH006	HU006	515	100	19.3

BENDMAX CAT.NO	WILA CAT.NO	LENGTH	Z	Max Loading (t/m)	Weight (kg/m)
ZWZIN002/Z3	INZU002/Z3	515	3	100($\alpha=90^\circ$)	6.3
ZWZIN002/Z4	INZU002/Z4	515	4		6.3
ZWZIN002/Z5	INZU002/Z5	515	5		6.3
ZWZIN002/Z6	INZU002/Z6	515	6		6.3
ZWZIN002/Z7	INZU002/Z7	515	7		6.3
ZWZIN002/Z8	INZU002/Z8	515	8		6.2

Punches Information

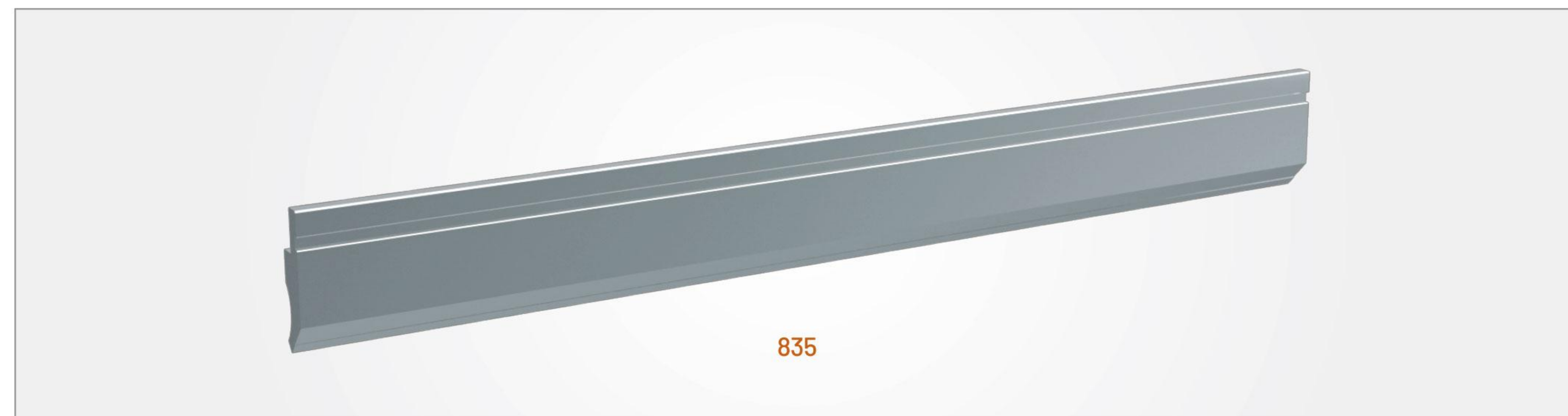
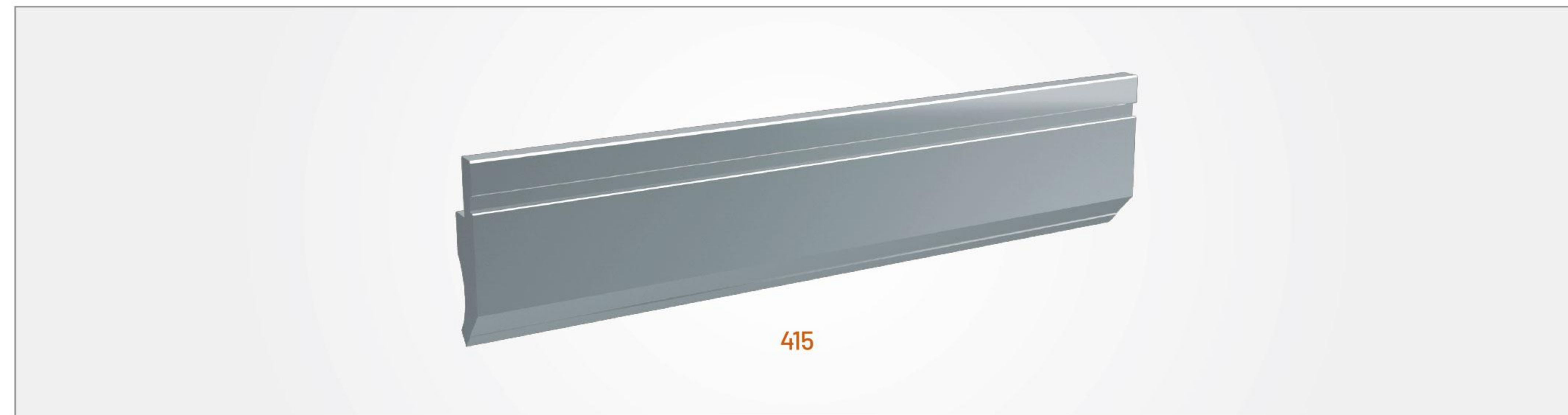

Standard Punches 75°

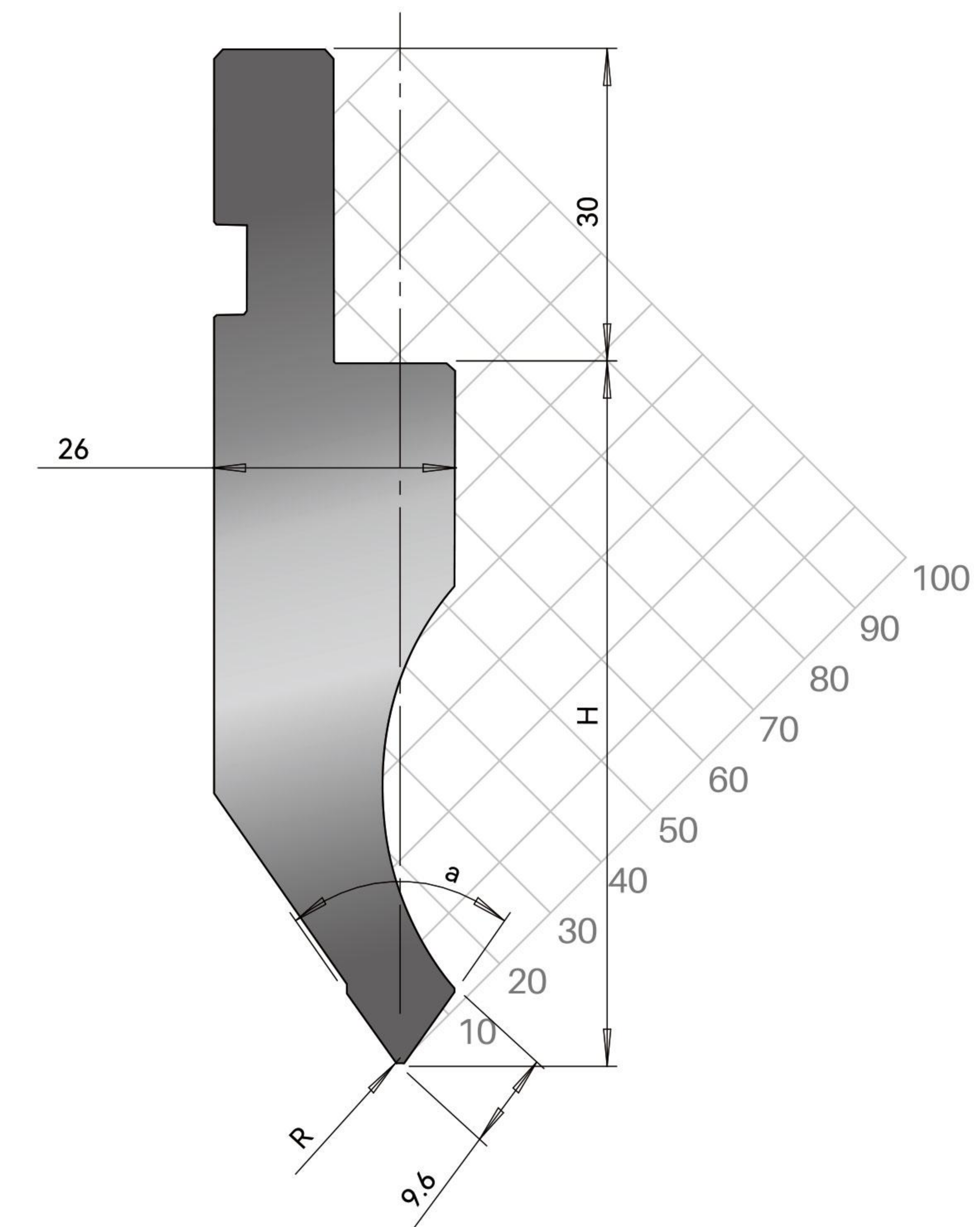

BENDMAX CAT.NO	R	a	H	Max Loading (t/m)	Weight(kg/m)
ZEP.S7508	0.8	75°	67.6	100	15
ZEP.S7515	1.5	75°	67.2	100	15
ZEP.S7530	3.0	75°	66.2	100	15



Standard Punches 88°&90°

PRESS BRAKE TOOLS-BENDMAX-EUROPEAN STYLE

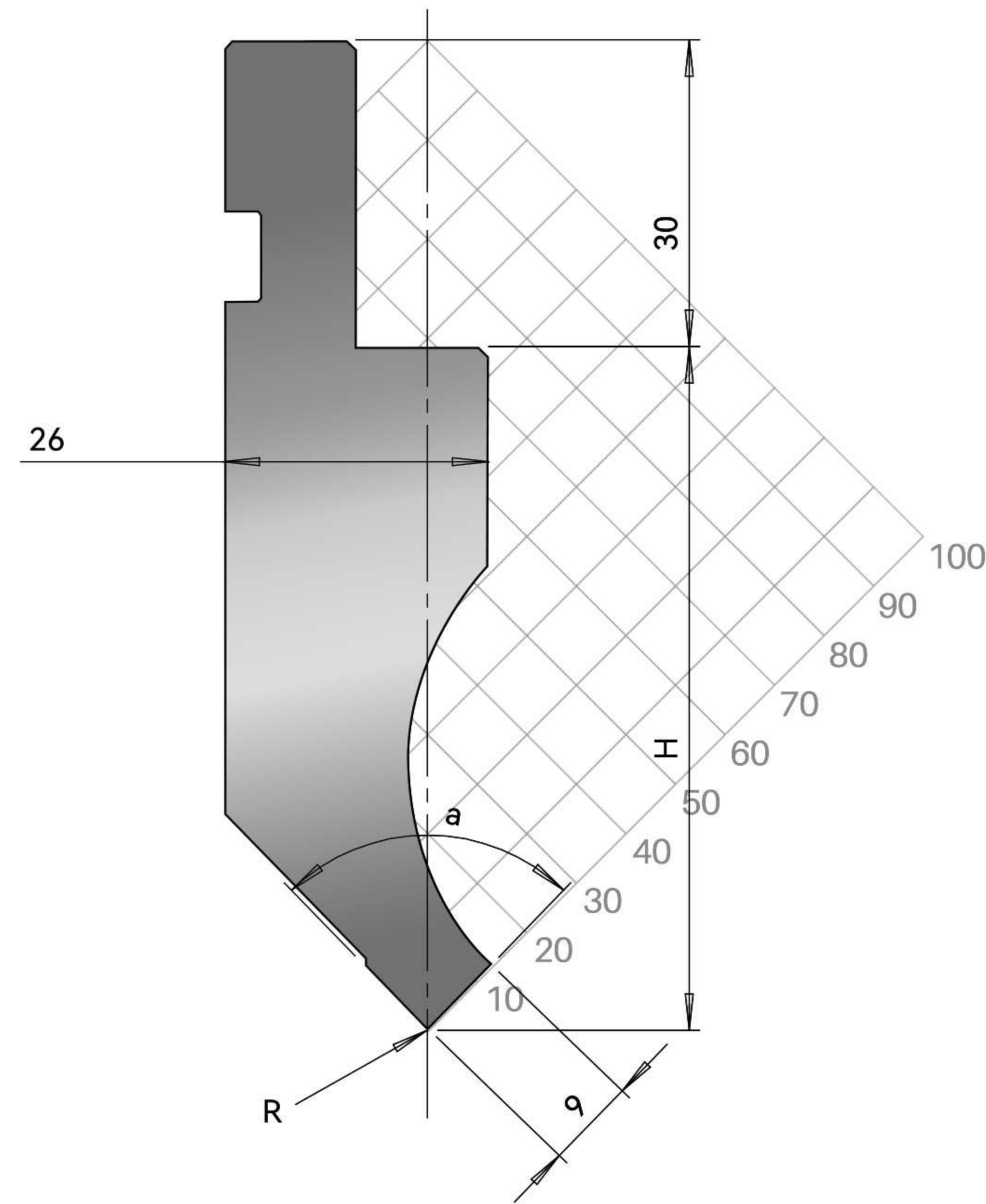

BENDMAX CAT.NO	R	a	H	Max Loading (t/m)	Weight(kg/m)
ZEP.S8802	0.2	88°	66.9	100	15
ZEP.S8808	0.8	88°	66.6	100	15
ZEP.S8815	1.5	88°	66.3	100	15
ZEP.S8823	2.3	88°	66.0	100	15
ZEP.S8830	3	88°	65.7	100	15

BENDMAX CAT.NO	R	a	H	Max Loading (t/m)	Weight(kg/m)
ZEP.S9002	0.2	90°	66.9	100	15
ZEP.S9008	0.8	90°	66.7	100	15
ZEP.S9015	1.5	90°	66.4	100	15
ZEP.S9023	2.3	90°	66.0	100	15
ZEP.S9030	3	90°	65.7	100	15



Gooseneck Punches 75°

PRESS BRAKE TOOLS-BENDMAX-EUROPEAN STYLE

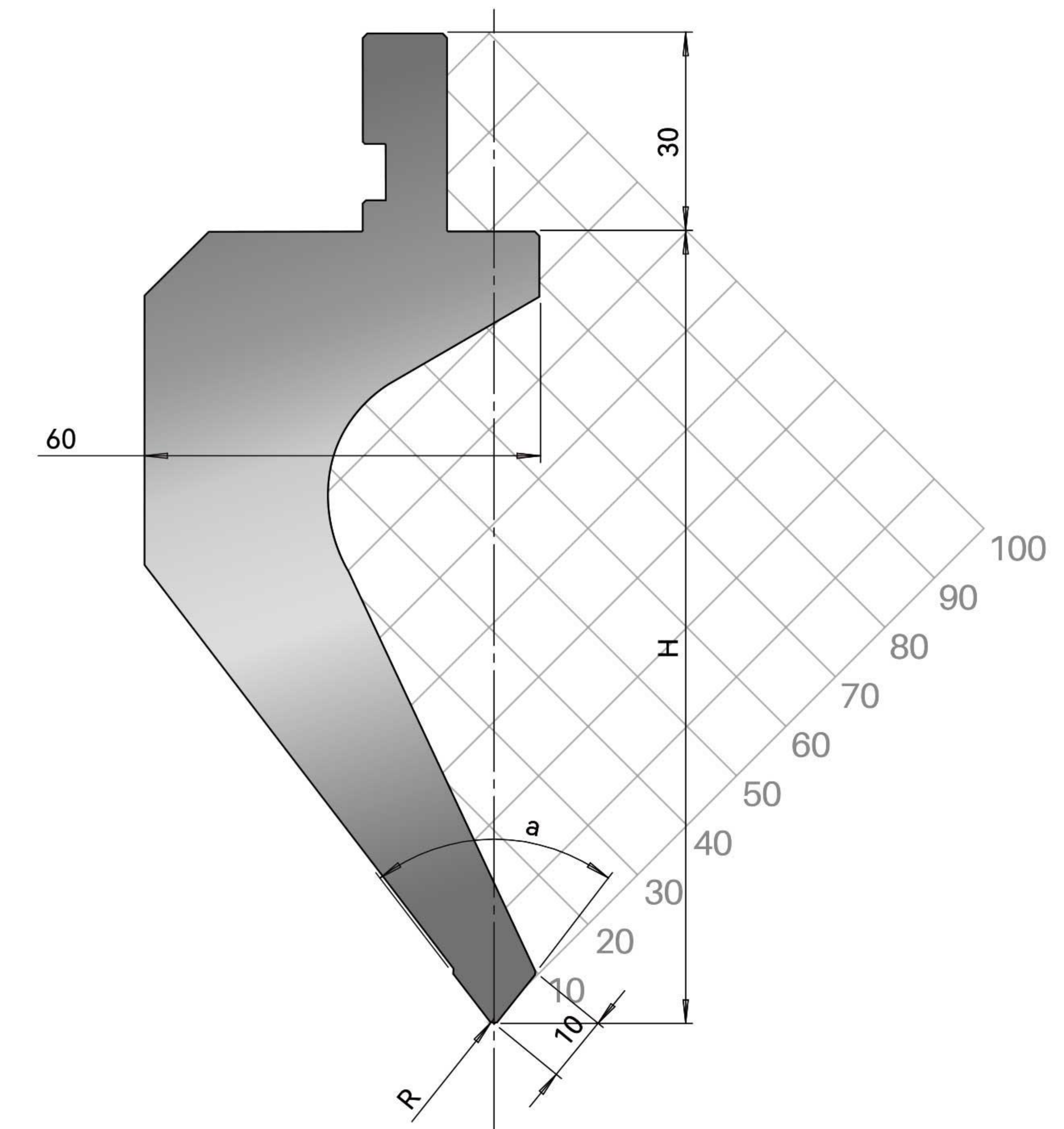

BENDMAX CAT.NO	R	a	H	Max Loading (t/m)	Weight(kg/m)
ZEP.G7508	0.8	75°	120	100	30
ZEP.G7515	1.5	75°	119.5	100	30
ZEP.G7530	3.0	75°	118.6	100	30



Gooseneck Punches 88° Short

PRESS BRAKE TOOLS-BENDMAX-EUROPEAN STYLE

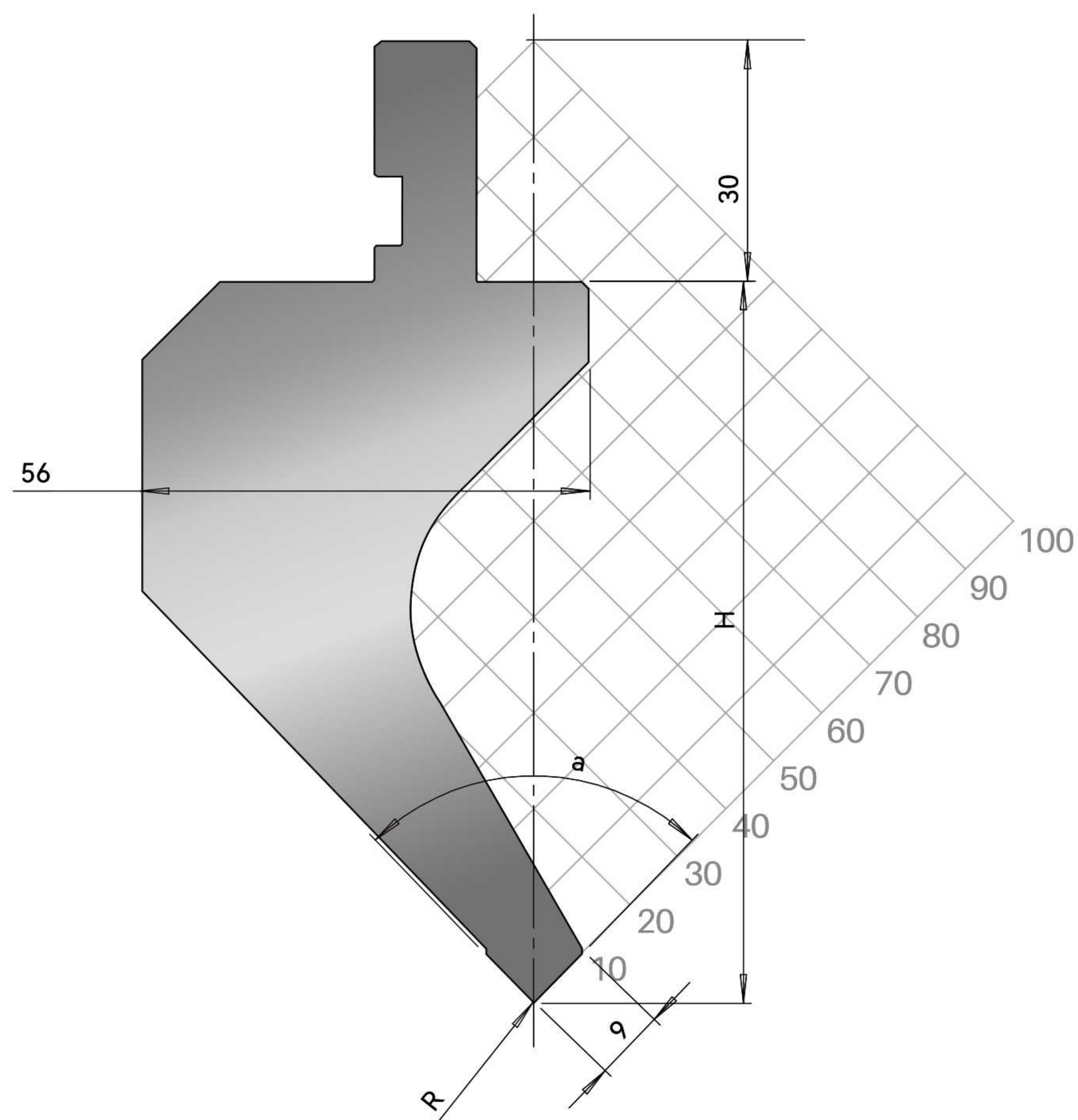

BENDMAX CAT.NO	R	a	H	Max Loading (t/m)	Weight(kg/m)
ZEP.G8802S	0.2	88°	89.9	70	24
ZEP.G8808S	0.8	88°	89.6	70	24
ZEP.G8815S	1.5	88°	89.3	70	24
ZEP.G8830S	3	88°	88.7	70	24



Gooseneck Punches 88°&90°

PRESS BRAKE TOOLS-BENDMAX-EUROPEAN STYLE

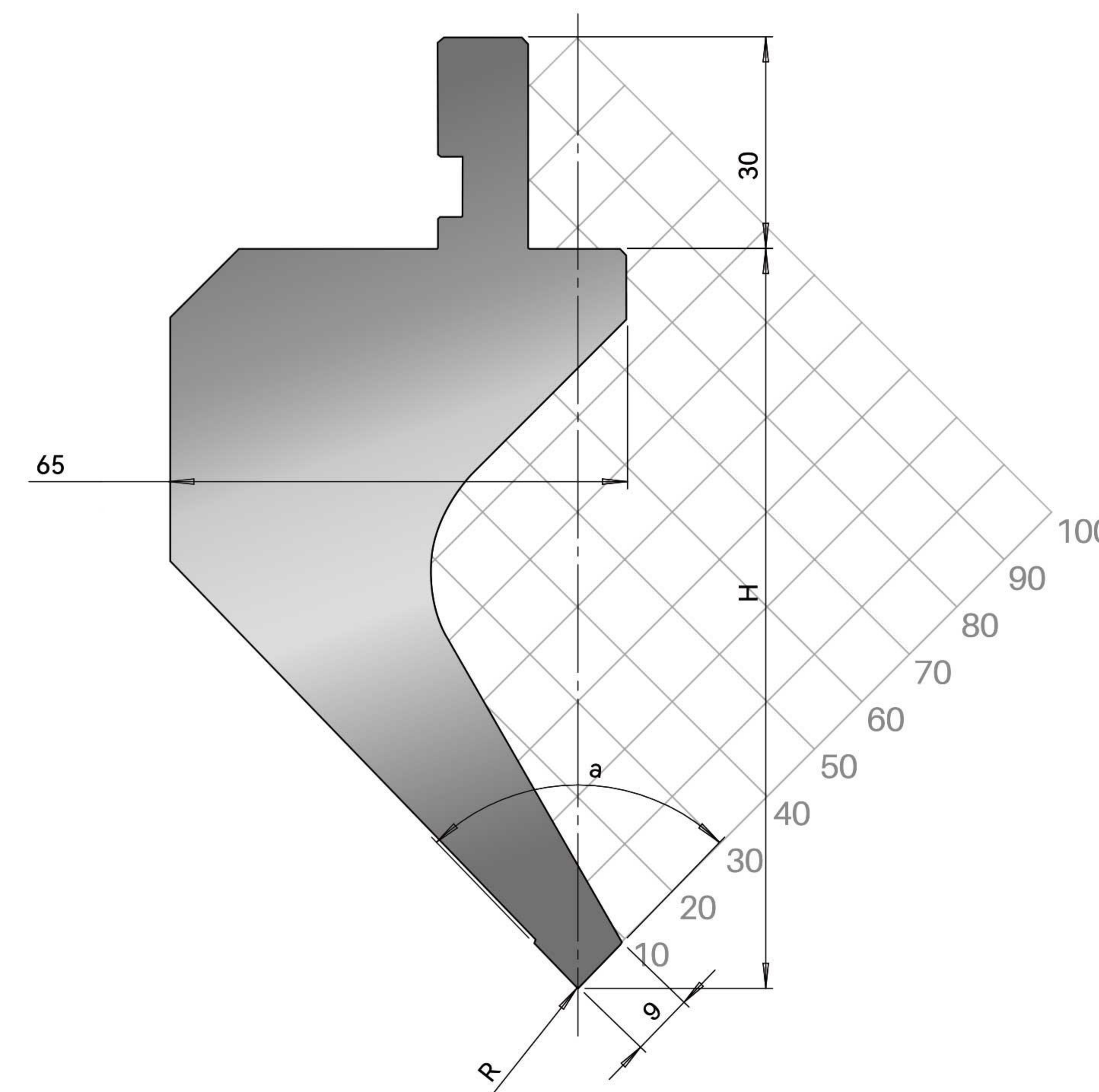

BENDMAX CAT.NO	R	a	H	Max Loading (t/m)	Weight(kg/m)
ZEP.G8802	0.2	88°	104.9	50	30
ZEP.G8808	0.8	88°	104.6	50	30
ZEP.G8815	1.5	88°	104.3	50	30
ZEP.G8830	3	88°	103.7	50	30
ZEP.G9002	0.2	90°	104.9	50	30



Gooseneck Punches 88° Tall

PRESS BRAKE TOOLS-BENDMAX-EUROPEAN STYLE

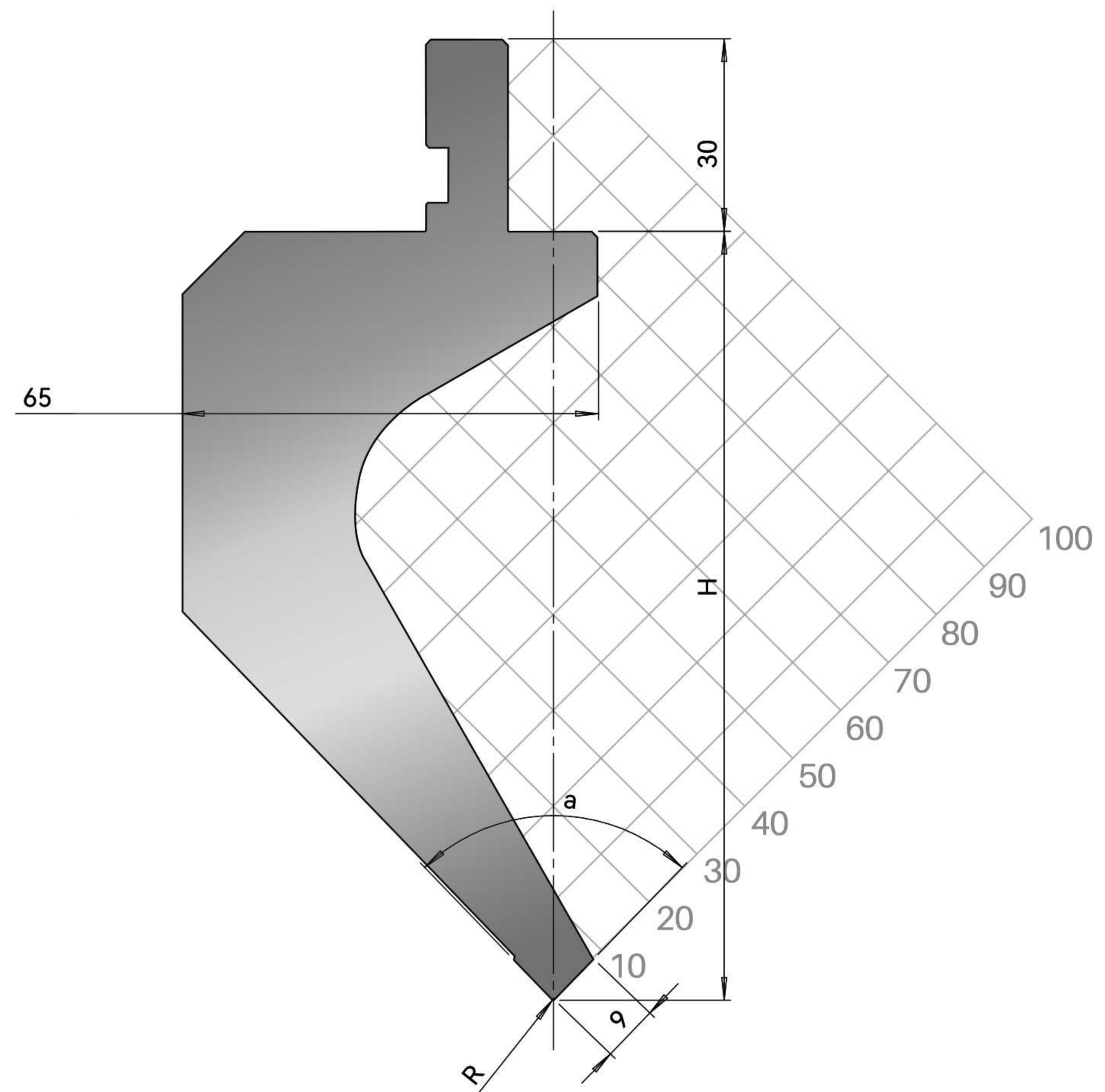

BENDMAX CAT.NO	R	a	H	Max Loading (t/m)	Weight(kg/m)
ZEP.G8802T	0.2	88°	119.9	50	32
ZEP.G8808T	0.8	88°	119.7	50	32



Gooseneck Punches 85°

PRESS BRAKE TOOLS-BENDMAX-EUROPEAN STYLE

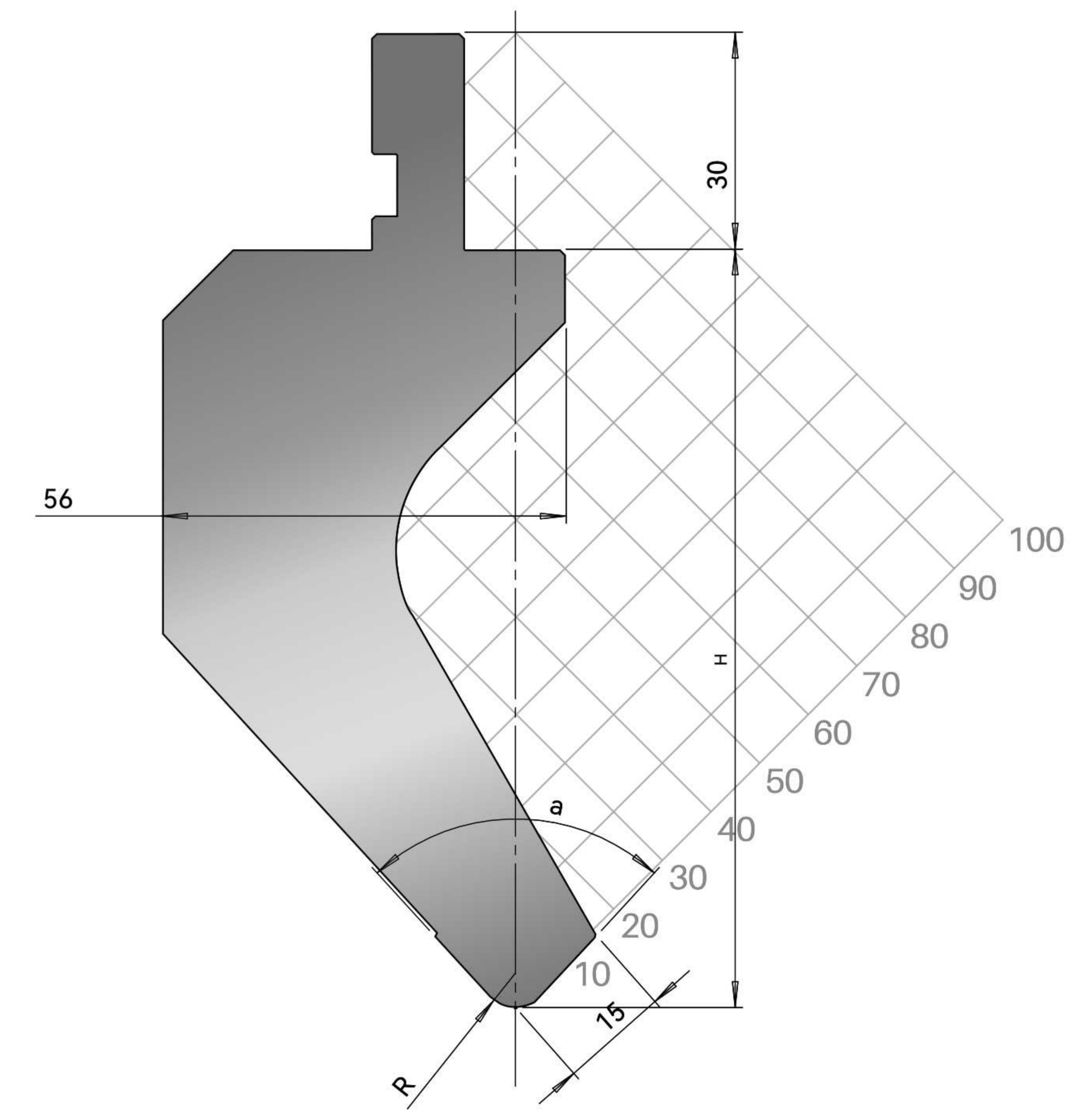

BENDMAX CAT.NO	R	a	H	Max Loading (t/m)	Weight(kg/m)
ZEP.G8548	4.8	85°	105	100	30
ZEP.G8564	6.4	85°	104.3	100	30



Narrow Punches 75°

PRESS BRAKE TOOLS-BENDMAX-EUROPEAN STYLE

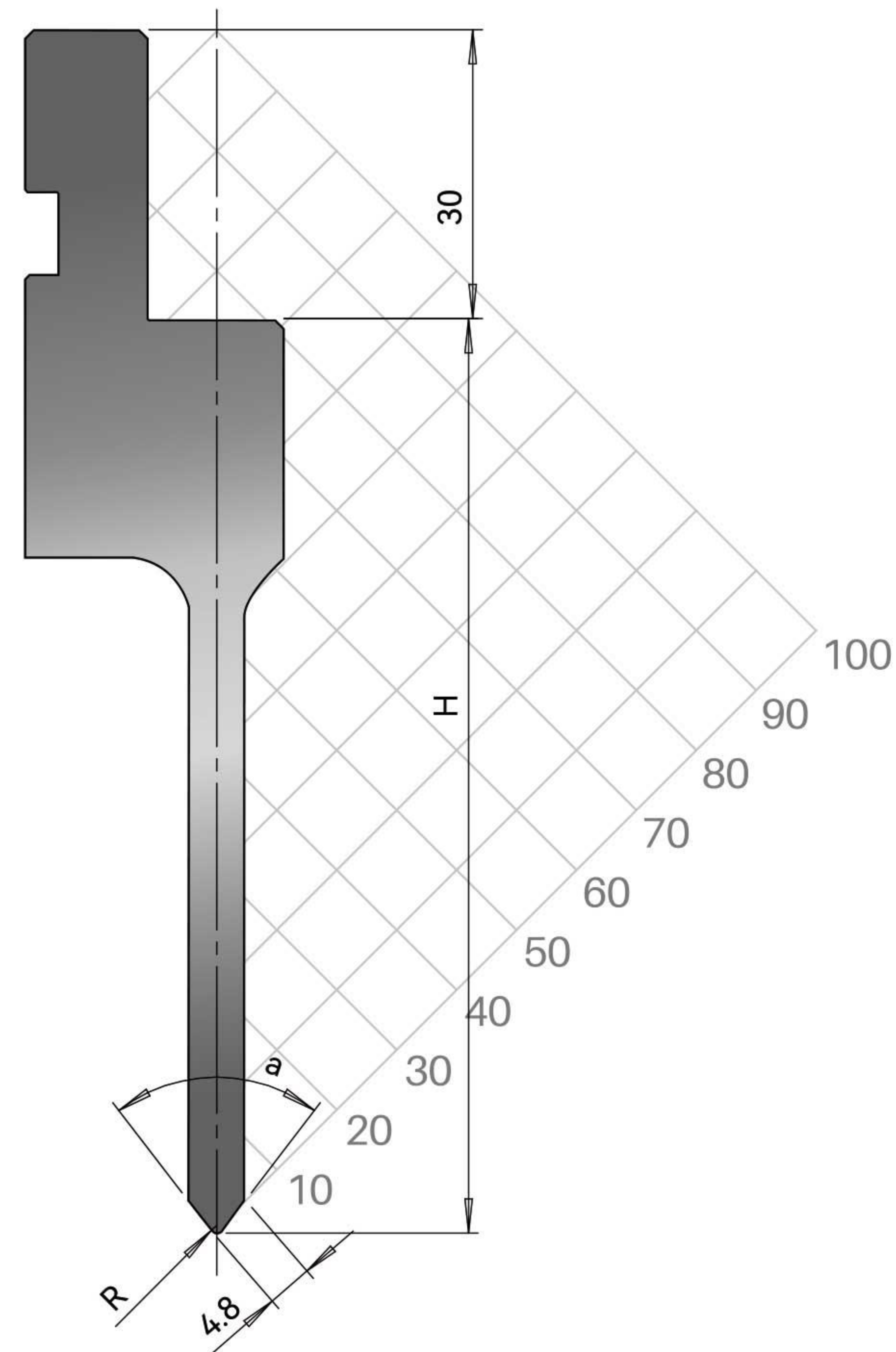

BENDMAX CAT.NO	R	a	H	Max Loading (t/m)	Weight(kg/m)
ZEP.N7508	0.8	75°	95	50	12



Narrow Punches 88°&90°

PRESS BRAKE TOOLS-BENDMAX-EUROPEAN STYLE

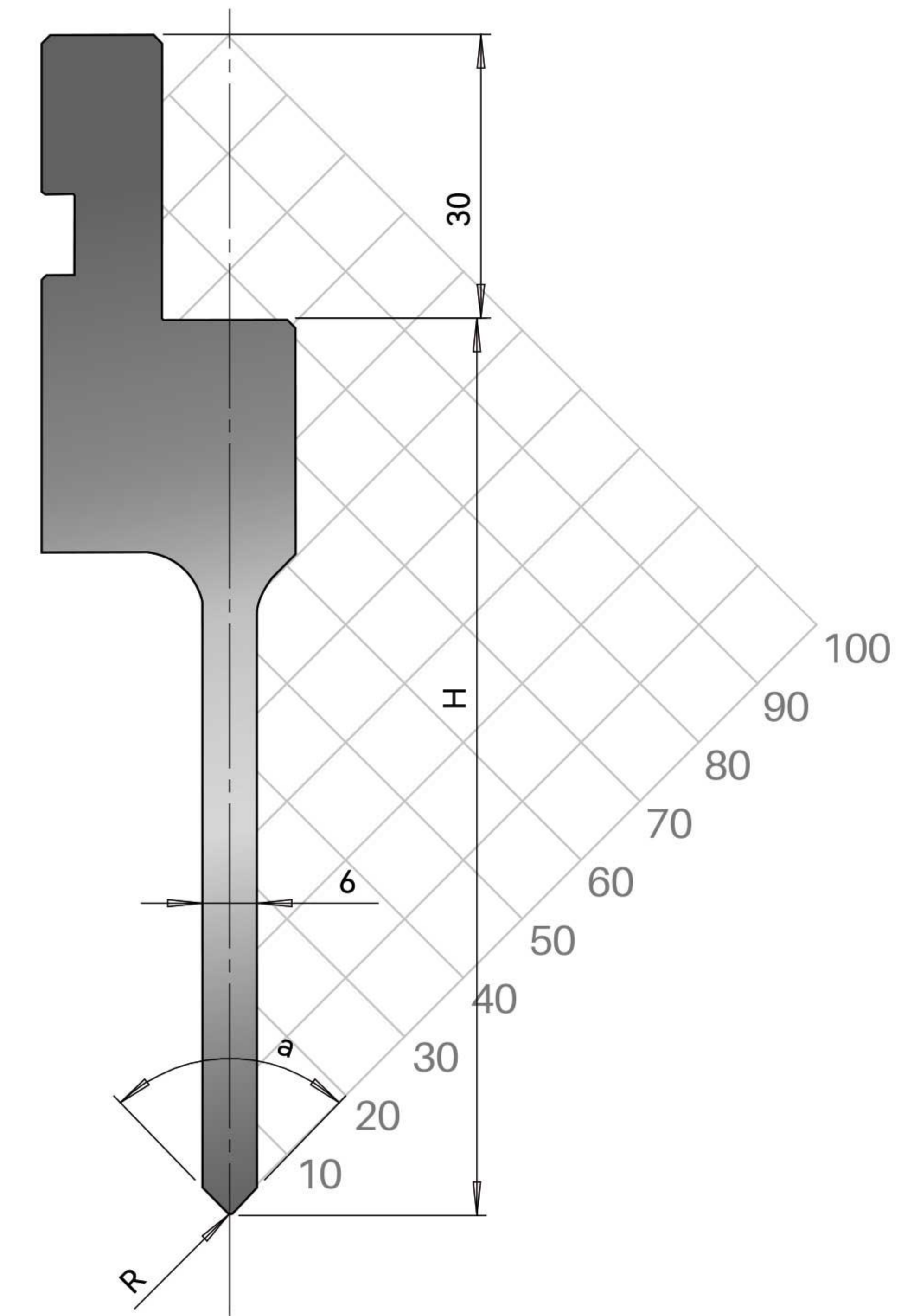

BENDMAX CAT.NO	R	a	H	Max Loading (t/m)	Weight(kg/m)
ZEP.N8802	0.2	88°	95	50	12
ZEP.N9002	0.2	90°	95	50	12



Sash Punches 88° TALL

PRESS BRAKE TOOLS-BENDMAX-EUROPEAN STYLE

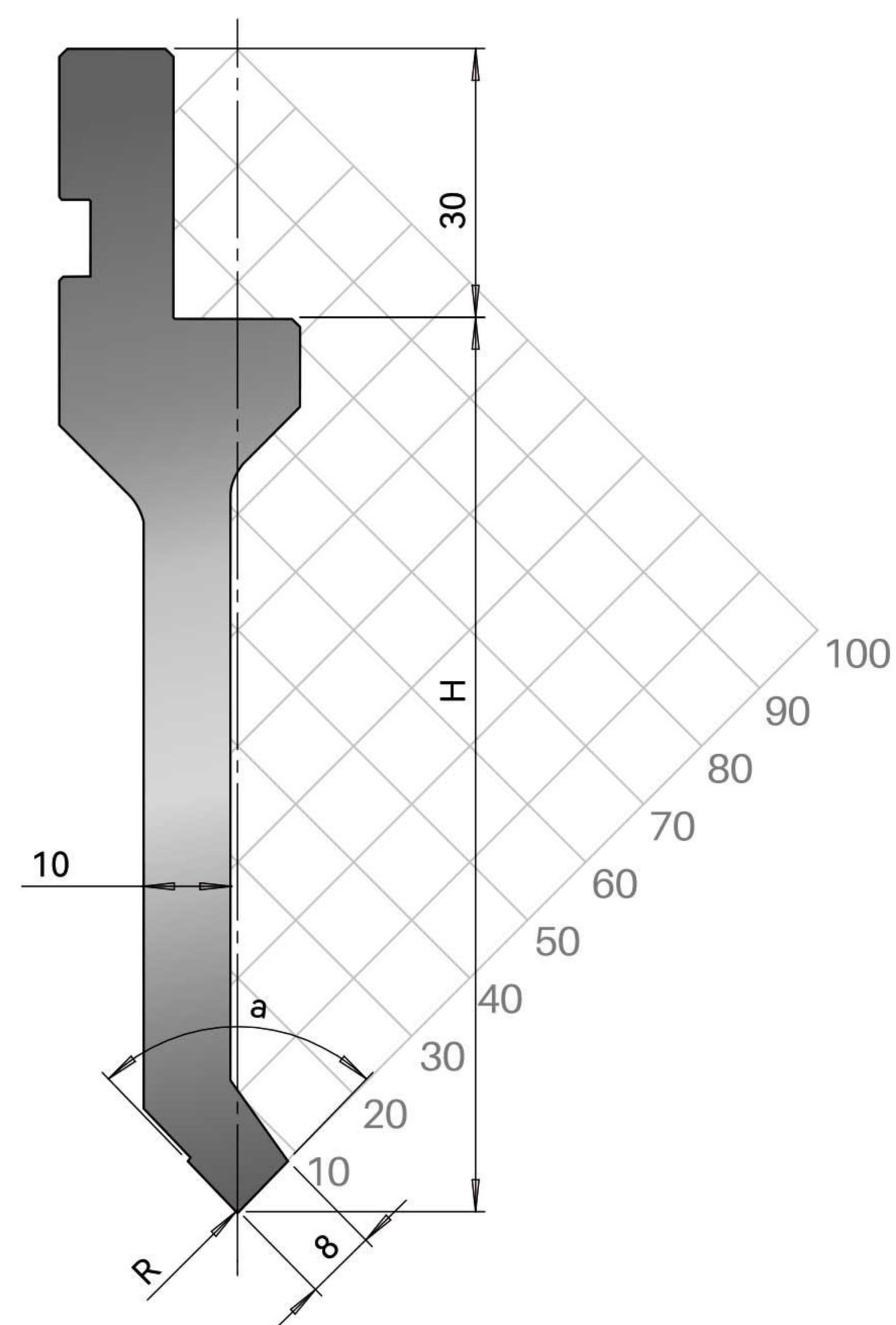

BENDMAX CAT.NO	R	a	H	Max Loading (t/m)	Weight(kg/m)
ZEP.SA8802T	0.2	88°	99.9	30	13



Sash Punches 88°&90°

PRESS BRAKE TOOLS-BENDMAX-EUROPEAN STYLE

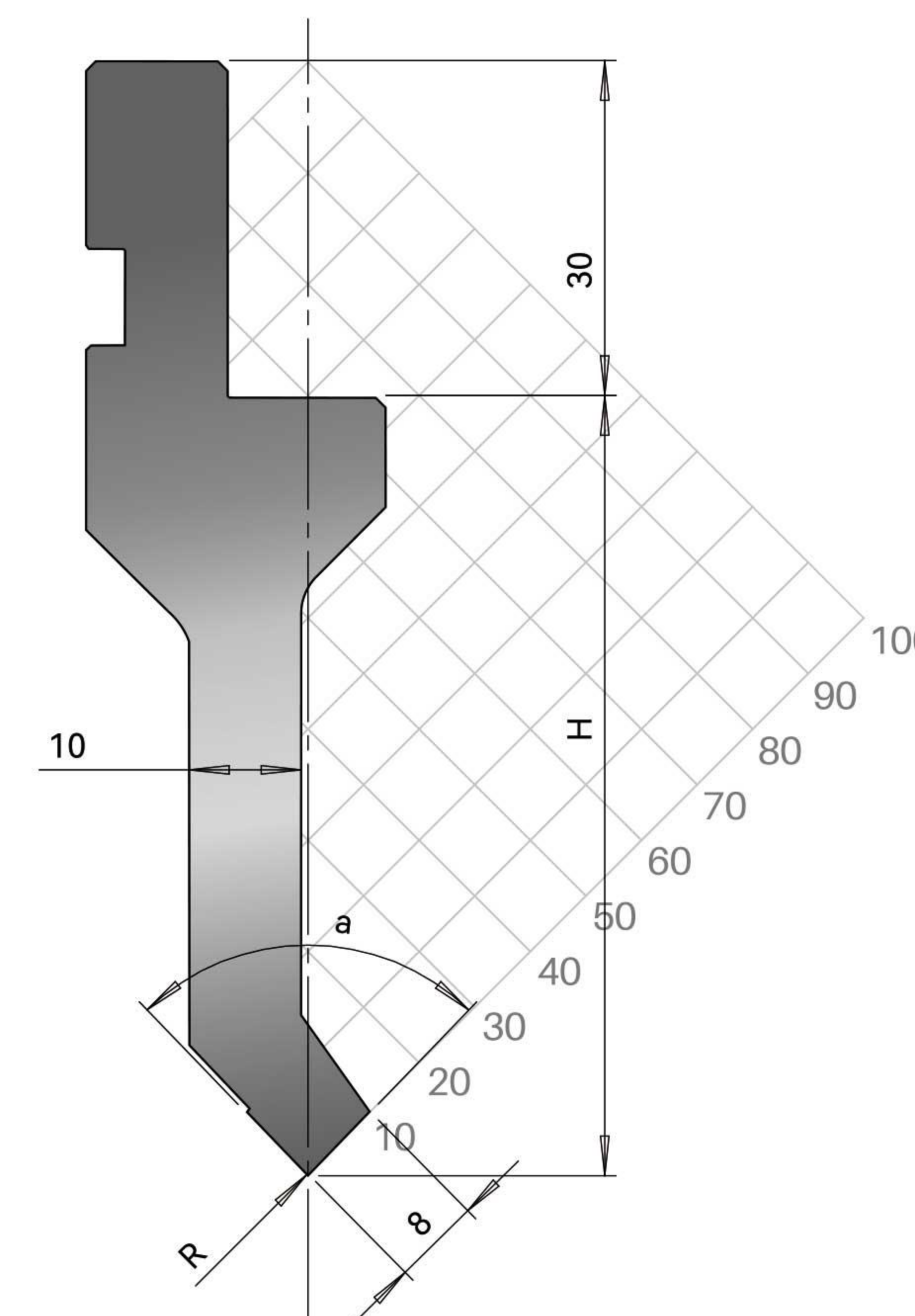

BENDMAX CAT.NO	R	a	H	Max Loading (t/m)	Weight(kg/m)
ZEP.SA8802	0.2	88°	69.9	30	11
ZEP.SA9002	0.2	90°	69.9	30	11



Acute Punches 30° Tall

PRESS BRAKE TOOLS-BENDMAX-EUROPEAN STYLE

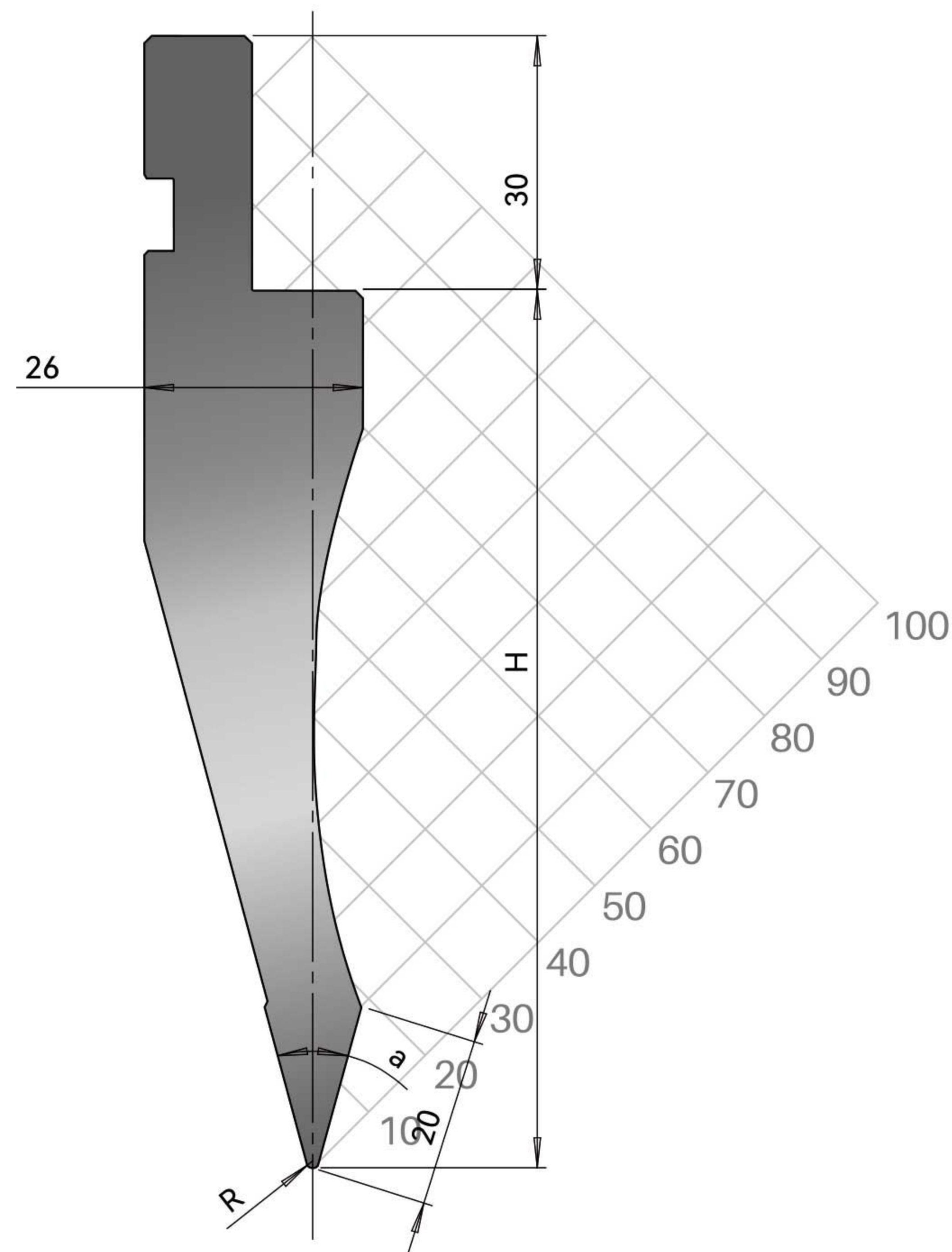

BENDMAX CAT.NO	R	a	H	Max Loading (t/m)	Weight(kg/m)
ZEP.A3008T	0.8	30°	104	100	16
ZEP.A3015T	1.5	30°	102	100	16
ZEP.A3023T	2.3	30°	99.7	100	16
ZEP.A3030T	3.0	30°	97.7	100	16
ZEP.A3048T	4.8	30°	92.7	100	16
ZEP.A3064T	6.35	30°	88.1	100	16



Acute Punches 35°

PRESS BRAKE TOOLS-BENDMAX-EUROPEAN STYLE

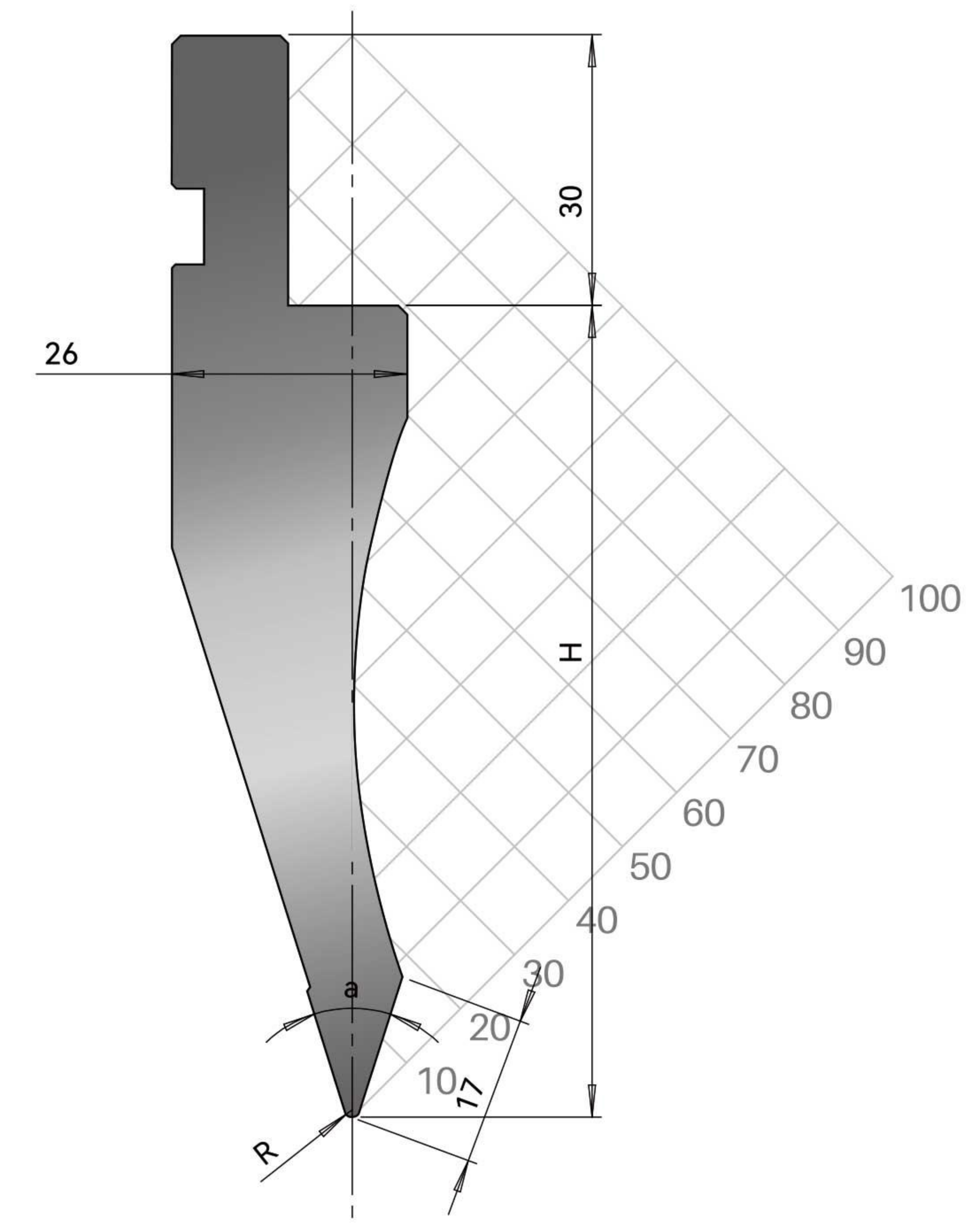

BENDMAX CAT.NO	R	a	H	Max Loading (t/m)	Weight(kg/m)
ZEP.A3508T	0.8	35°	90	70	14
ZEP.A3515T	1.5	35°	86	70	13.5



Acute Punches 30° Short

PRESS BRAKE TOOLS-BENDMAX-EUROPEAN STYLE

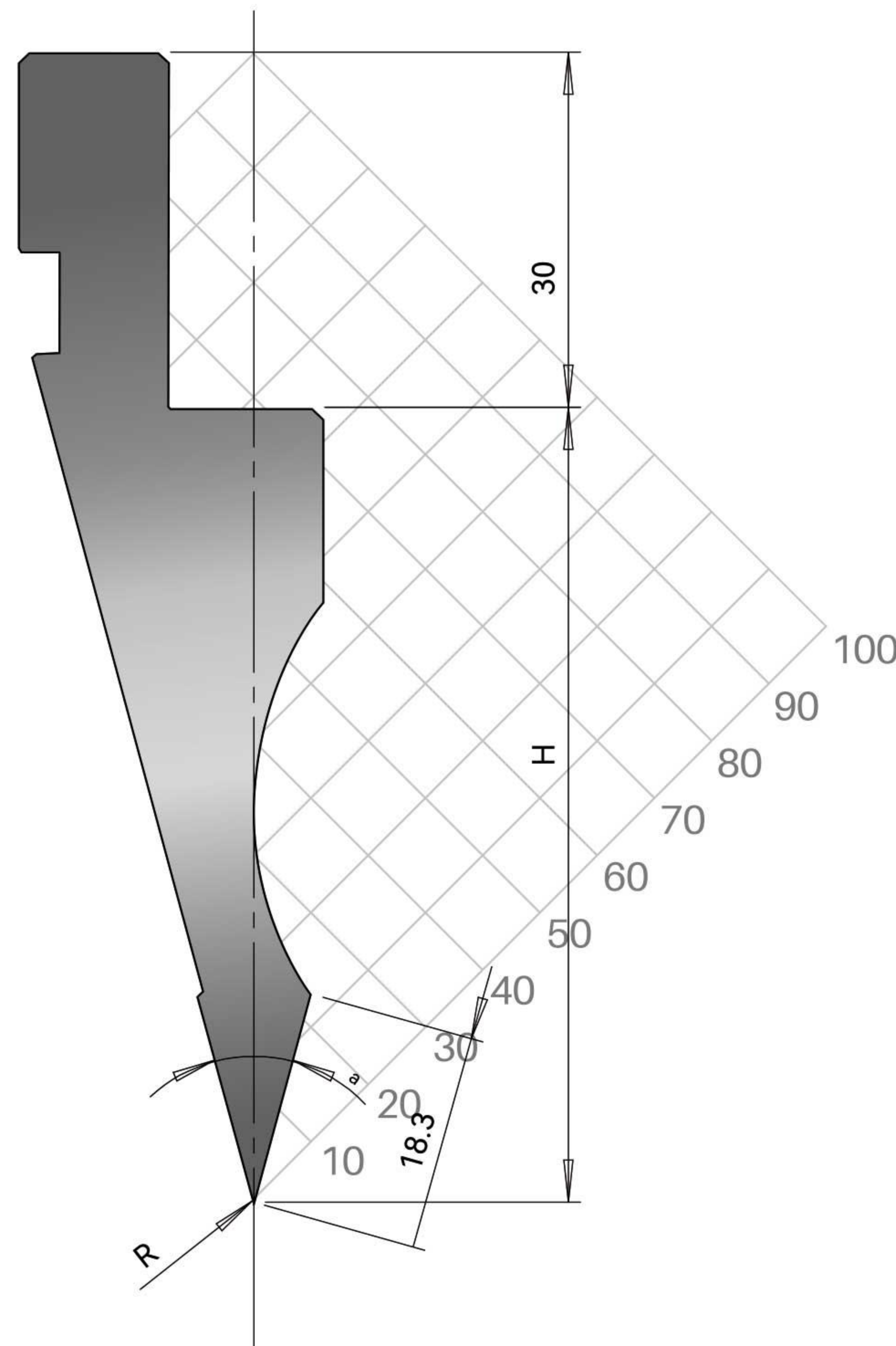

BENDMAX CAT.NO	R	a	H	Max Loading (t/m)	Weight(kg/m)
ZEP.A3002S	0.2	30°	67.2	100	9
ZEP.A3008S	0.8	30°	65.5	100	9



Acute Punches 60°

PRESS BRAKE TOOLS-BENDMAX-EUROPEAN STYLE

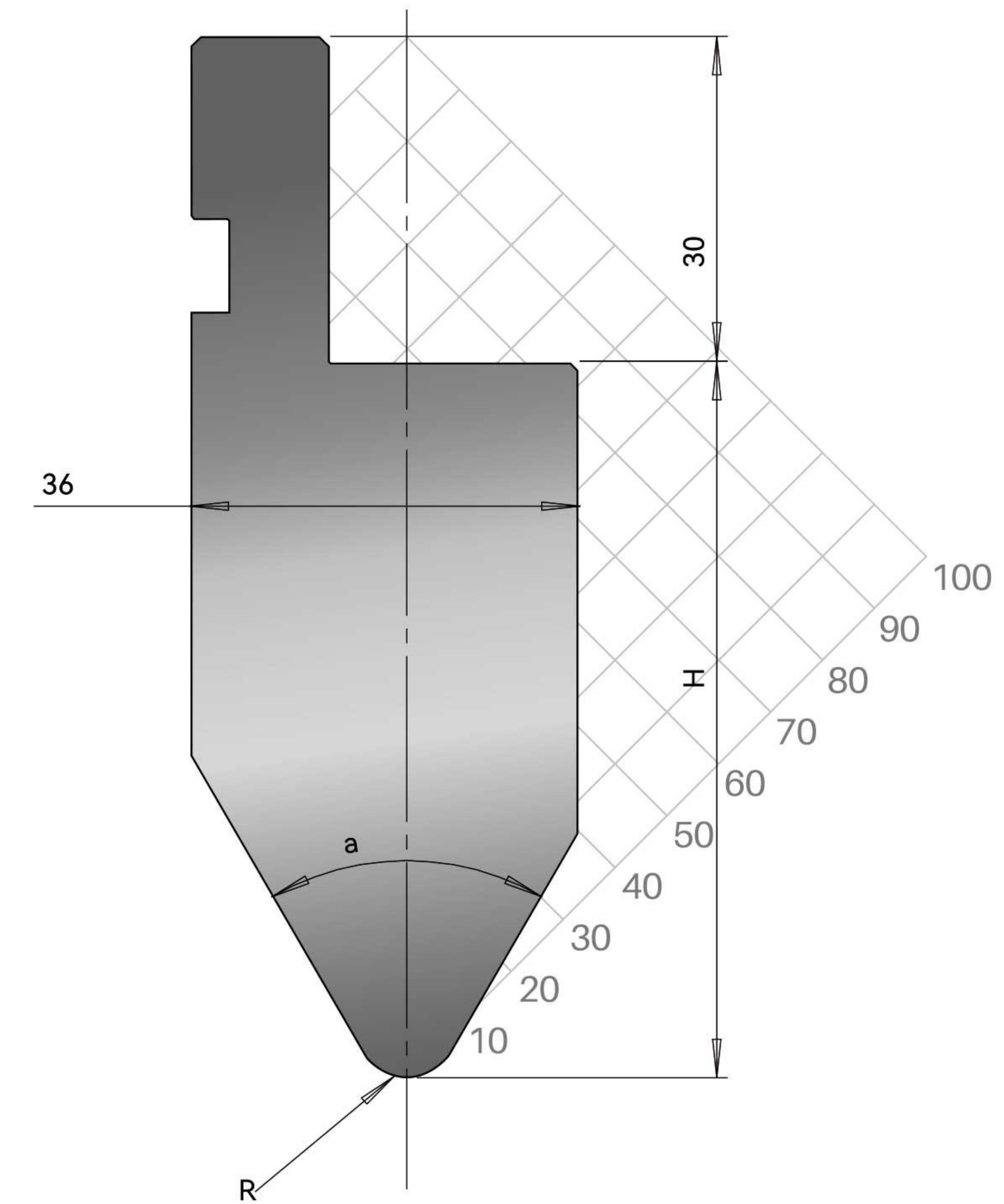

BENDMAX CAT.NO	R	a	H	Max Loading (t/m)	Weight(kg/m)
ZEP.A6048	4.8	60°	66.2	100	18
ZEP.A6060	6.0	60°	65	100	18

Dies Information

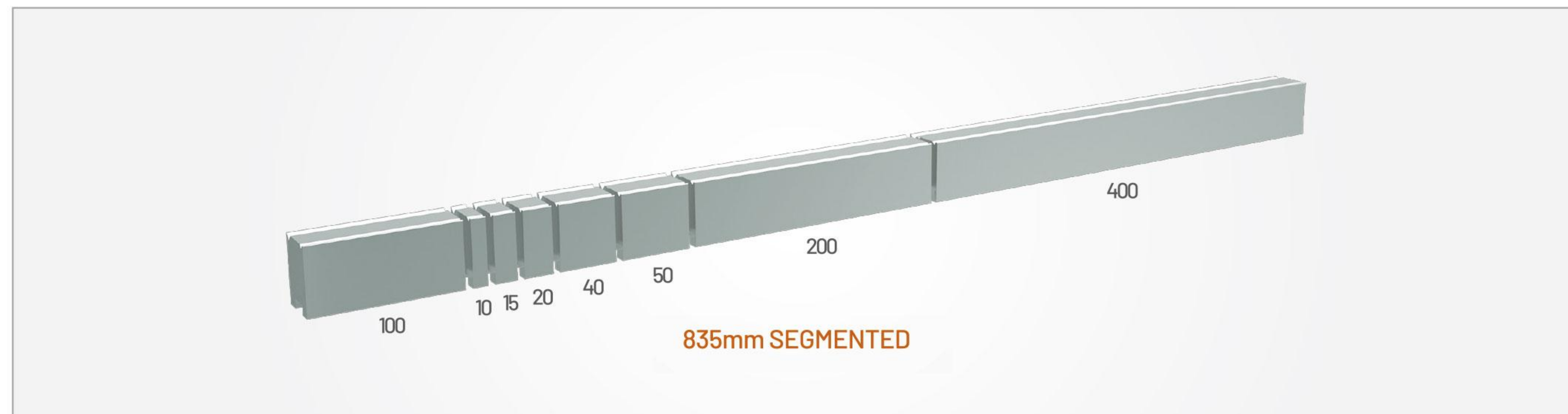
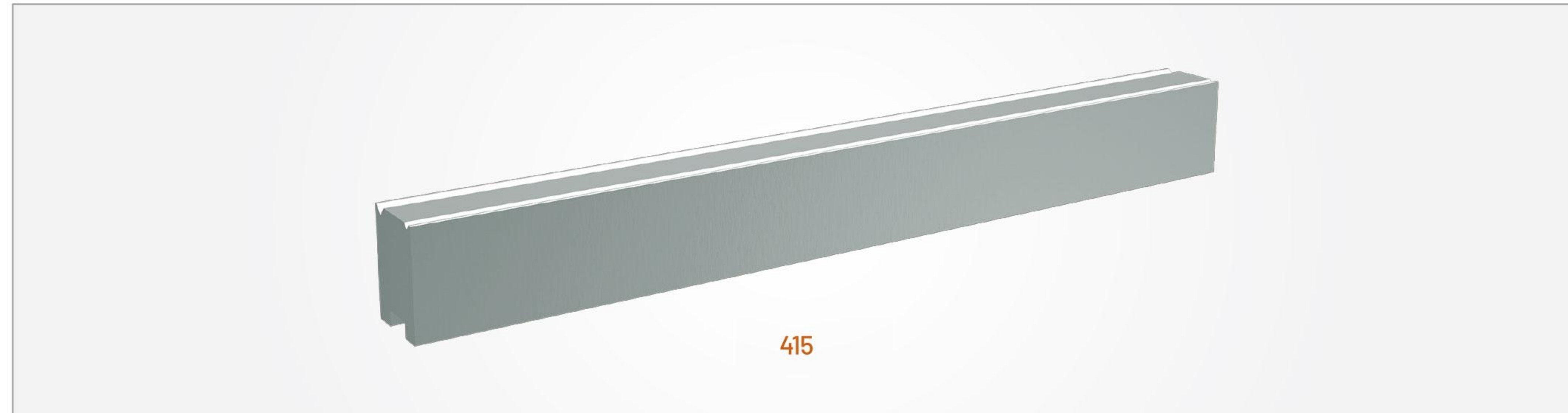

1VM14 Die

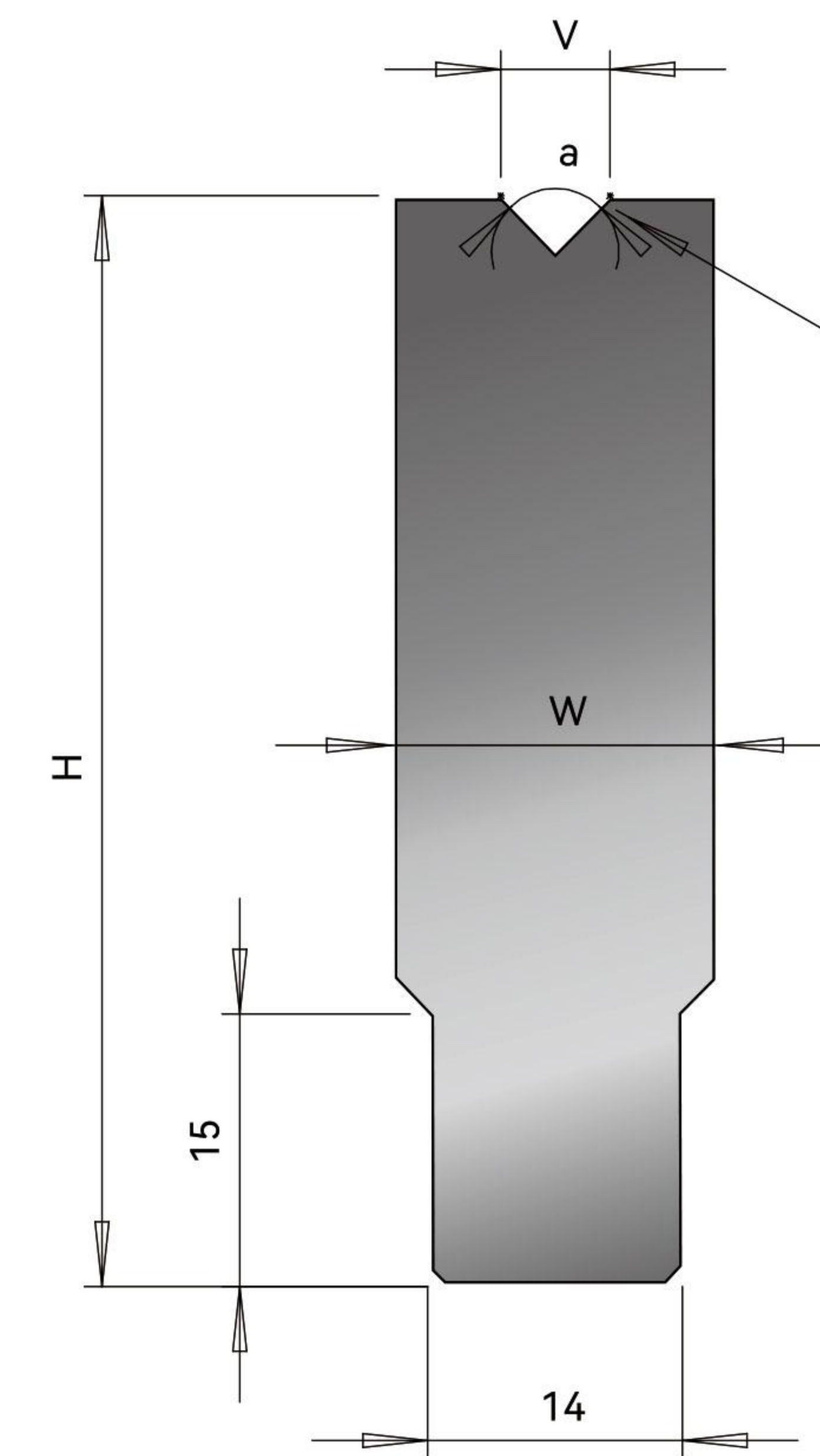

BENDMAX CAT.NO	V	a	R	W	H	Max Loading (t/m)	Weight(kg/m)
ZED.1VM14.88V4	4	88°	0.6	14	60	100	7
ZED.1VM14.88V6	6	88°	0.8	14	60	100	7
ZED.1VM14.88V8	8	88°	1.0	14	60	100	7
ZED.1VM14.88V10	10	88°	1.2	18	60	100	8
ZED.1VM14.88V12	12	88°	1.5	18	60	100	8
ZED.1VM14.88V16	16	88°	2.0	24	60	100	10
ZED.1VM14.88V20	20	88°	2.0	30	60	100	11
ZED.1VM14.88V25	25	88°	3.0	35	60	100	13

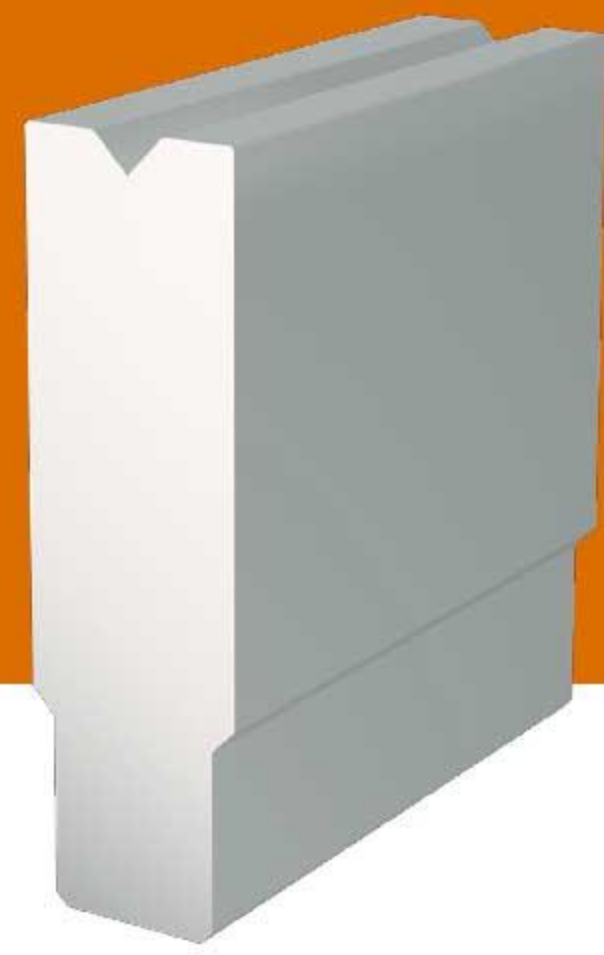

1VM14 Die

PRESS BRAKE TOOLS-BENDMAX-EUROPEAN STYLE

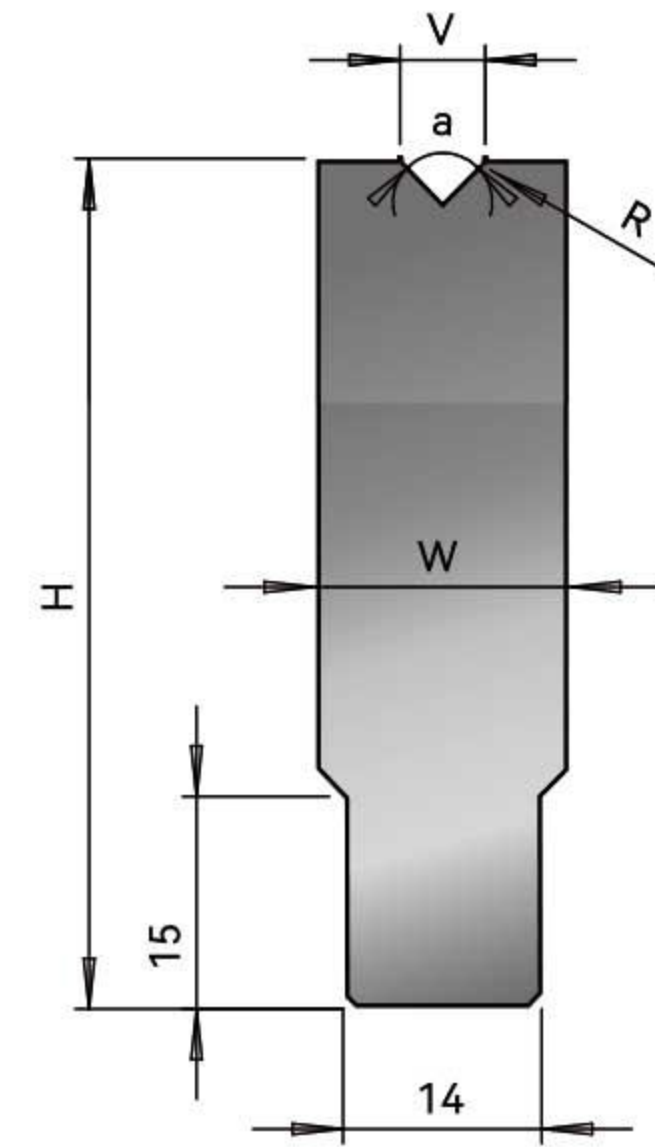

BENDMAX CAT.NO	V	a	R	B	W	H	Max Loading (t/m)	Weight(kg/m)
ZED.1VM14.30V6	6	30°	0.6	X	14	60	35	6
ZED.1VM14.30V8	8	30°	0.8	2	18	60	35	8
ZED.1VM14.30V10	10	30°	1.0	2	24	60	50	9
ZED.1VM14.30V12	12	30°	1.5	2	24	60	40	9
ZED.1VM14.30V16	16	30°	2.0	5	30	60	45	10
ZED.1VM14.30V20	20	30°	2.5	5	35	60	50	11
ZED.1VM14.30V25	25	30°	3.0	8	45	65	50	13

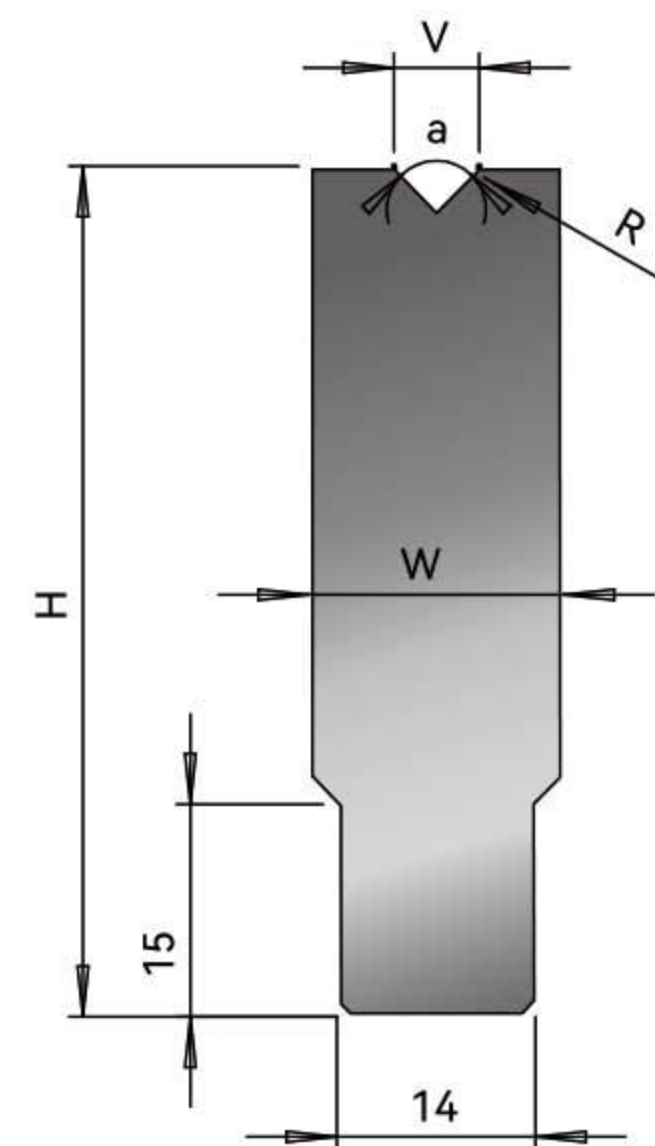

BENDMAX CAT.NO	V	a	R	W	H	Max Loading (t/m)	Weight(kg/m)
ZED.1VM14.75V3	3	75°	0.4	14	60	100	7
ZED.1VM14.75V6	6	75°	1.5	14	60	100	6
ZED.1VM14.75V10	10	75°	2.5	17	60	100	7
ZED.1VM14.75V12	12	75°	3.0	19	60	100	8
ZED.1VM14.75V16	16	75°	3.5	24	60	100	9
ZED.1VM14.75V20	20	75°	4.0	28	60	100	10
ZED.1VM14.88V22	22	75°	4.5	30	60	100	11
ZED.1VM14.88V25	25	75°	5.5	36	60	100	13

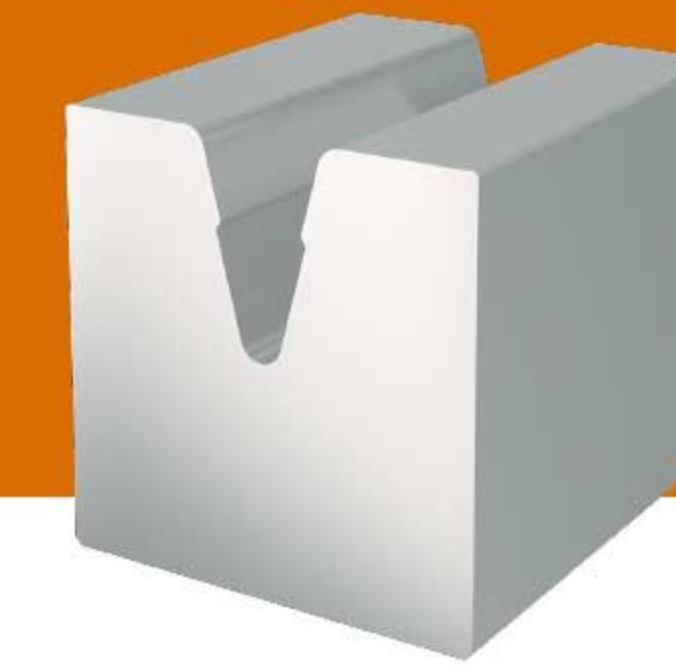

1VM60.30 Die

PRESS BRAKE TOOLS-BENDMAX-EUROPEAN STYLE

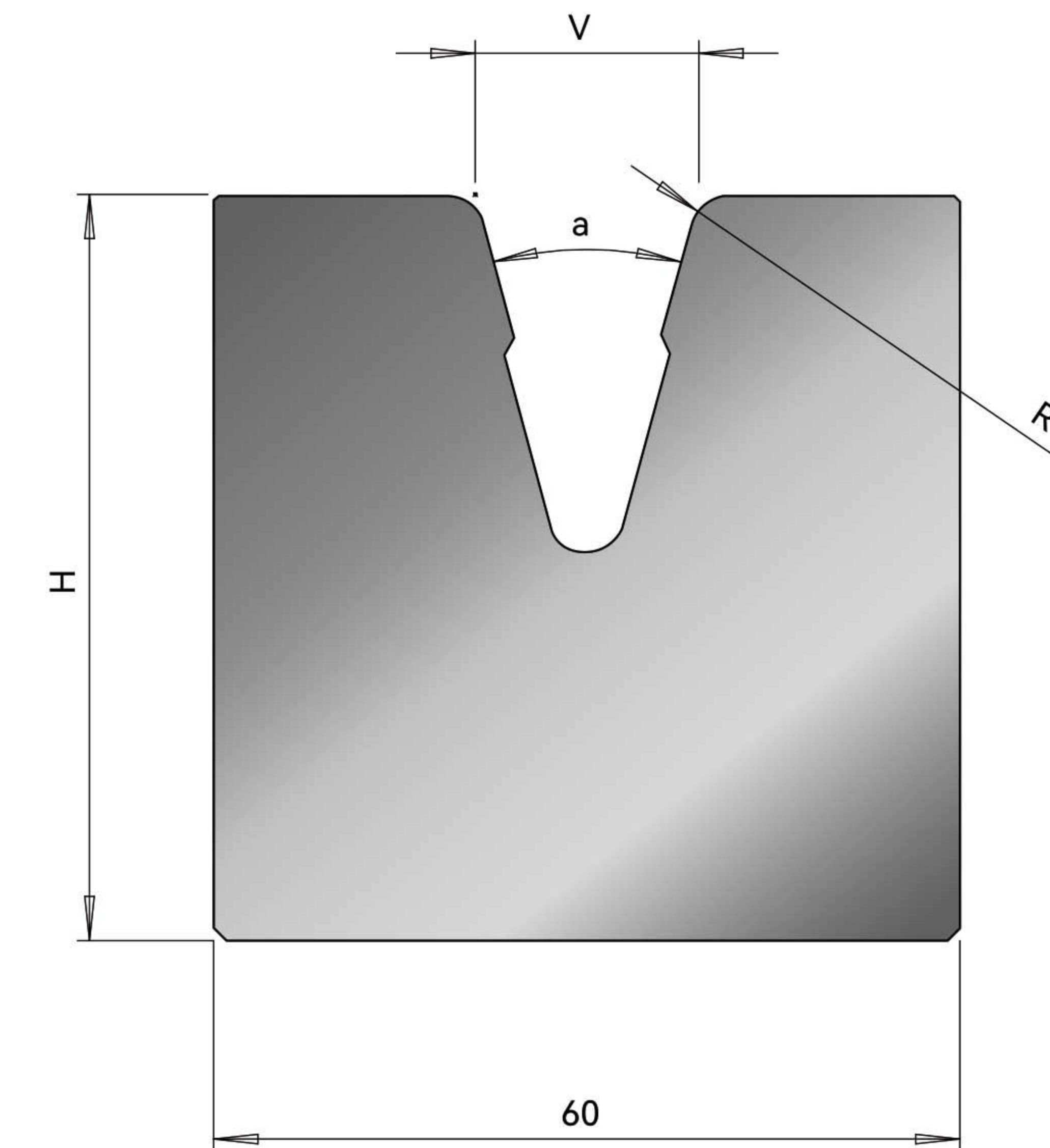

BENDMAX CAT.NO	V	a	R	W	Max Loading (t/m)	Weight(kg/m)
ZED.1VM60.30V18	18	30°	3.0	60	80	26
ZED.1VM60.30V25	25	30°	4.0	65	60	26

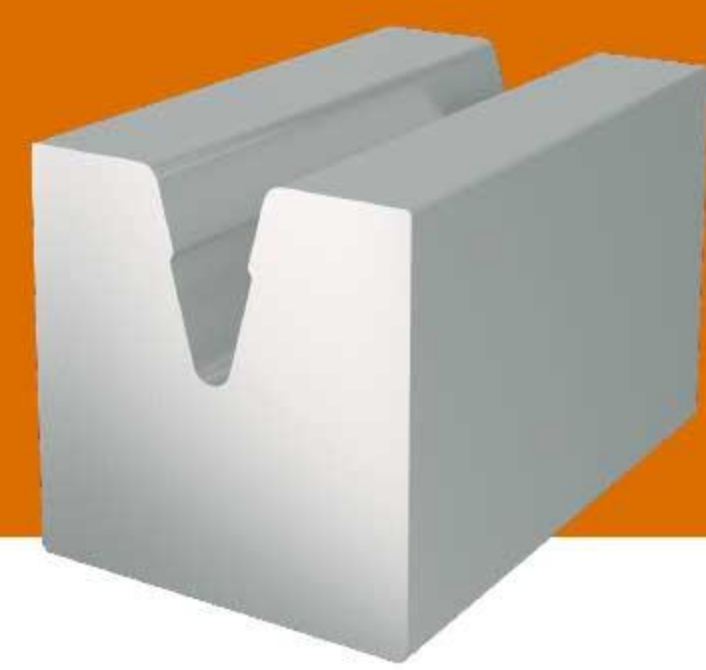

1VM60.45 Die

PRESS BRAKE TOOLS-BENDMAX-EUROPEAN STYLE

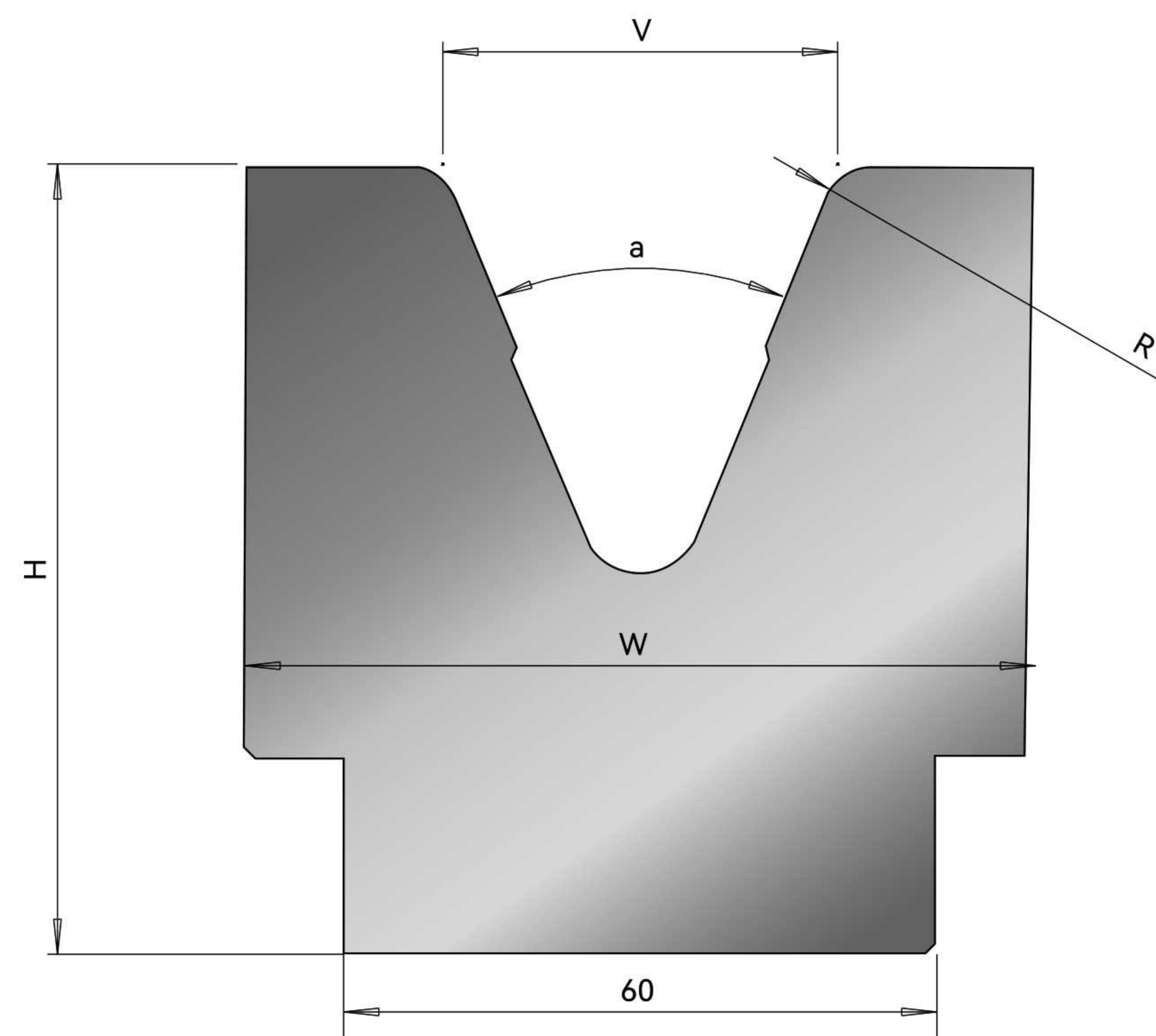

BENDMAX CAT.NO	V	a	R	W	H	Max Loading (t/m)	Weight(kg/m)
ZED.1VM60.45V32	32	45°	5.0	60	60	40	23
ZED.1VM60.45V40	40	45°	5.0	80	80	70	39
ZED.1VM60.45V50	50	45°	6.0	95	95	70	52



1VH80.26 Die

PRESS BRAKE TOOLS-BENDMAX-EUROPEAN STYLE

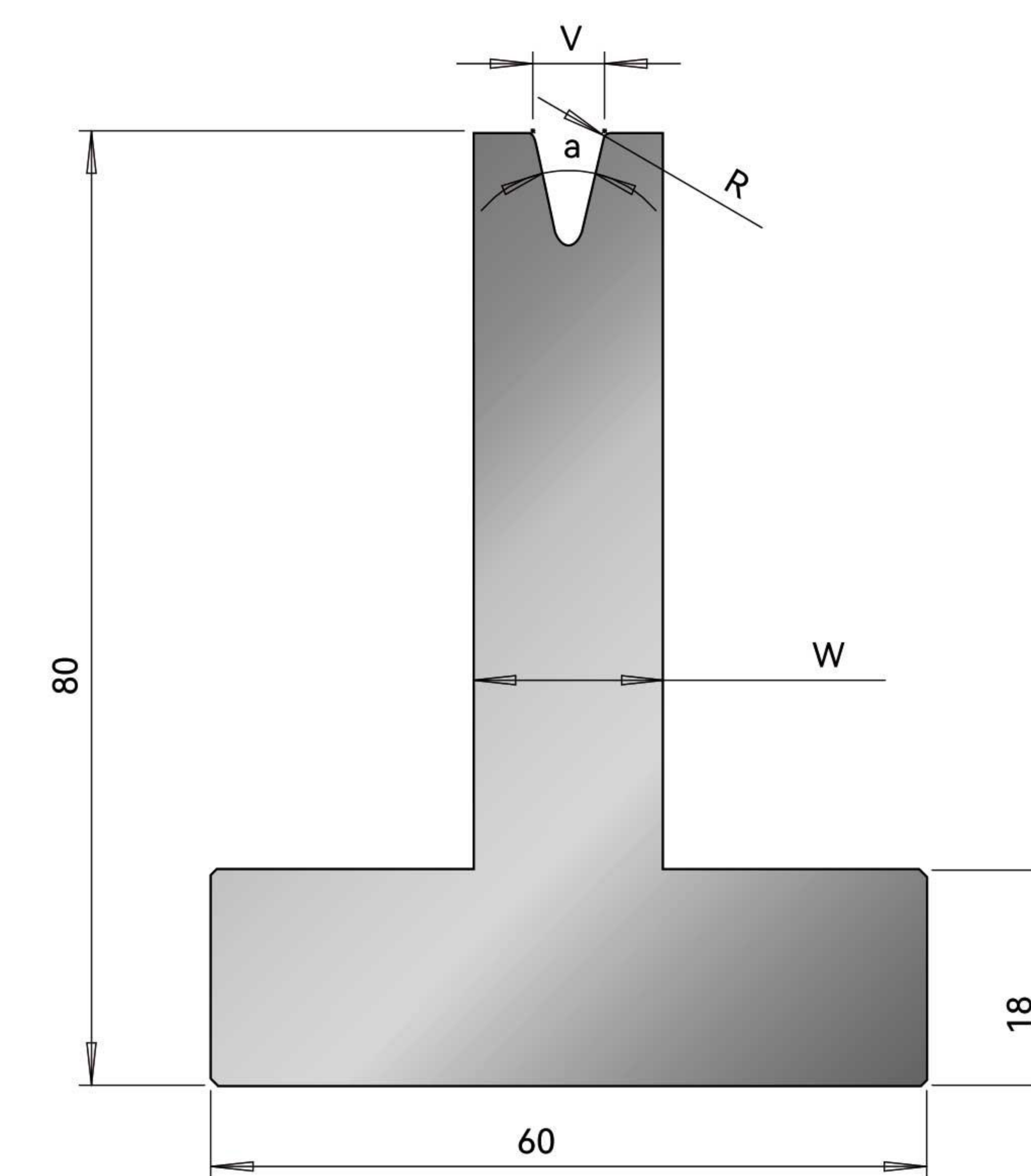

BENDMAX CAT.NO	V	a	R	W	Max Loading (t/m)	Weight(kg/m)
ZED.1VH80.26V6	6	26°	0.8	16	25	6
ZED.1VH80.26V8	8	26°	1.0	20	25	18
ZED.1VH80.26V10	10	26°	1.2	24	25	19
ZED.1VH80.26V12	12	26°	1.6	26	25	20

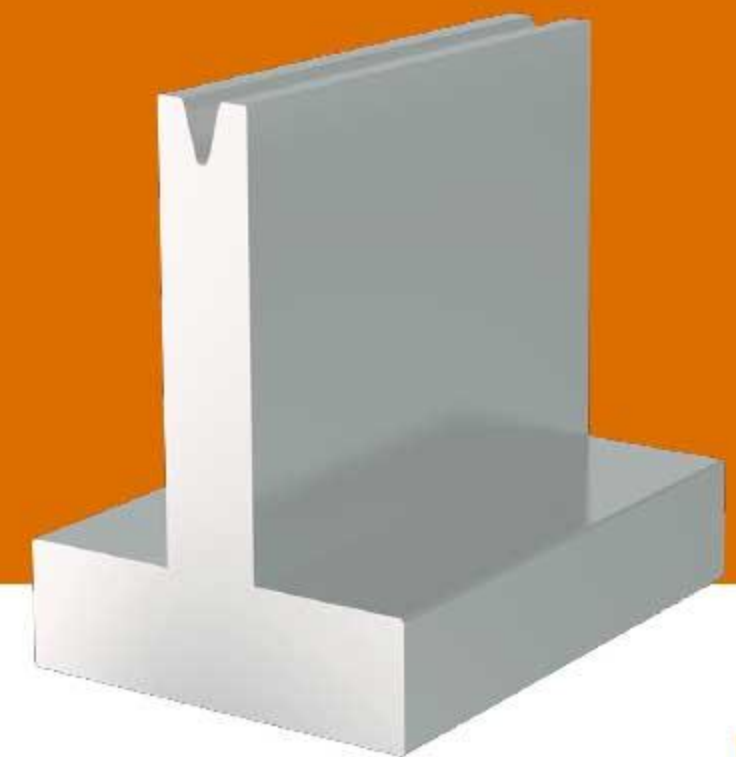

1VH80.30 Die

PRESS BRAKE TOOLS-BENDMAX-EUROPEAN STYLE

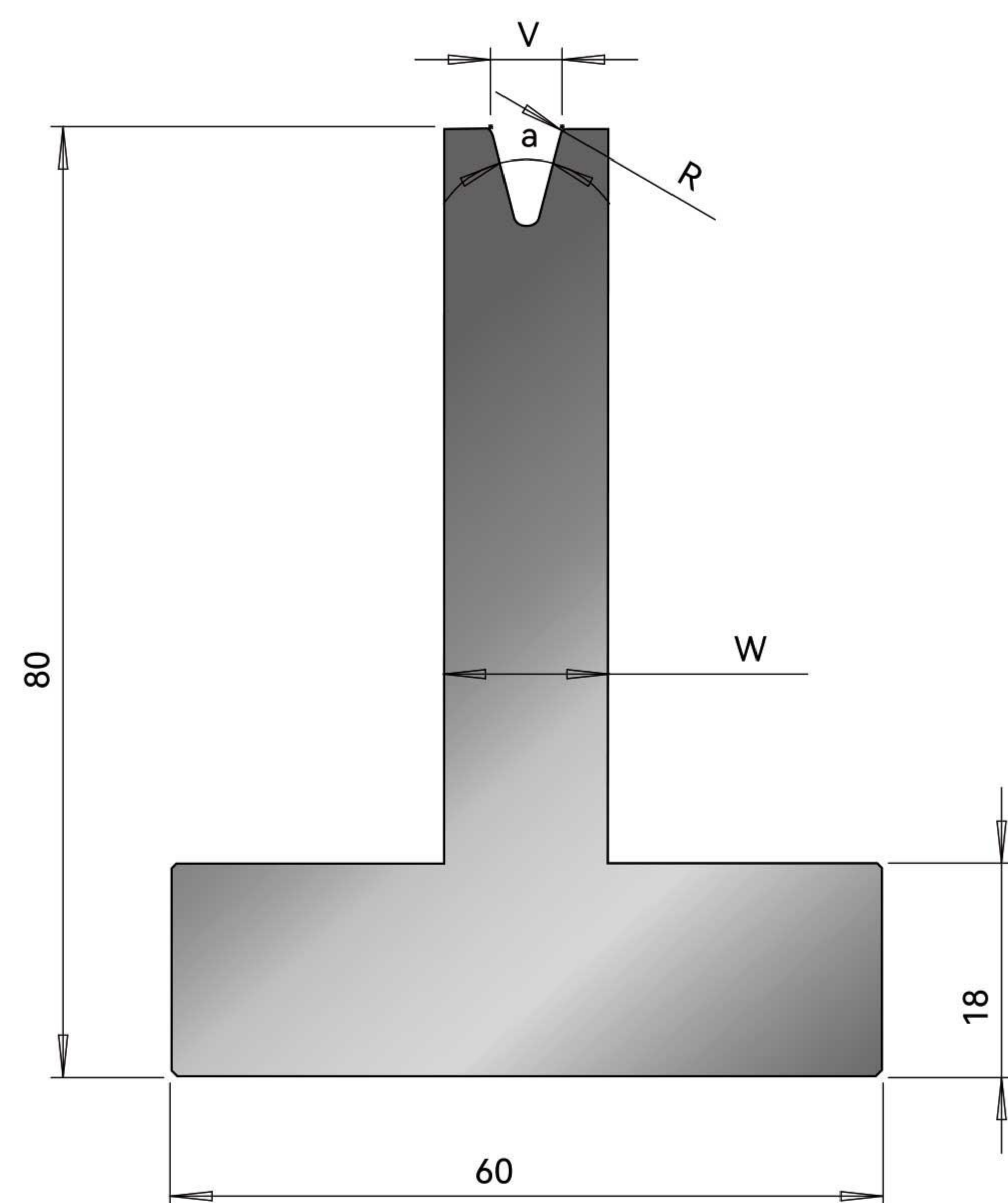

BENDMAX CAT.NO	V	a	R	W	Max Loading (t/m)	Weight(kg/m)
ZED.1VH80.30V6	6	30°	0.6	14	35	15
ZED.1VH80.30V8	8	30°	0.8	18	35	17
ZED.1VH80.30V10	10	30°	1.0	24	50	19
ZED.1VH80.30V12	12	30°	1.5	24	40	19
ZED.1VH80.30V16	16	30°	2.0	30	45	21
ZED.1VH80.30V20	20	30°	2.5	35	50	23
ZED.1VH80.30V25	25	30°	3.0	40	50	24

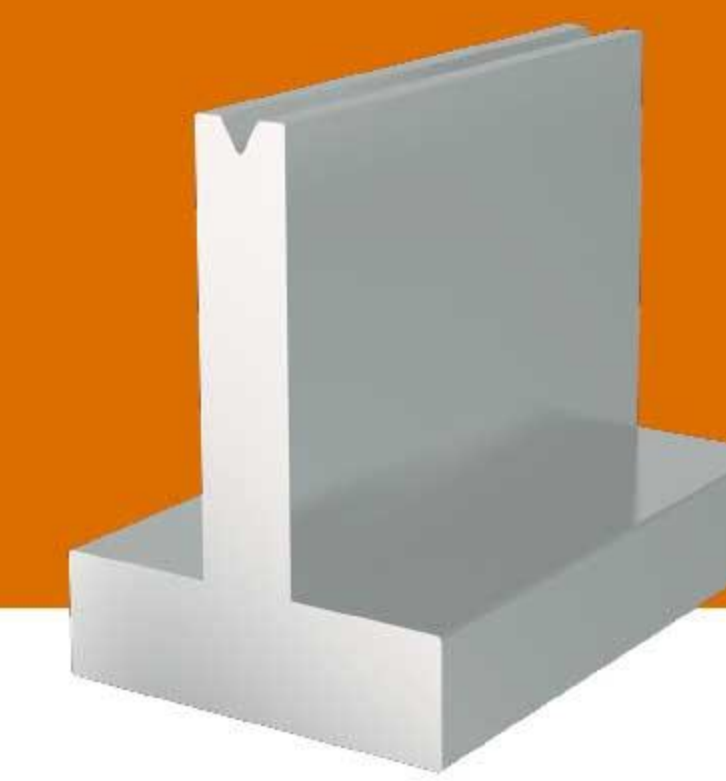

1VH80.60 Die

PRESS BRAKE TOOLS-BENDMAX-EUROPEAN STYLE

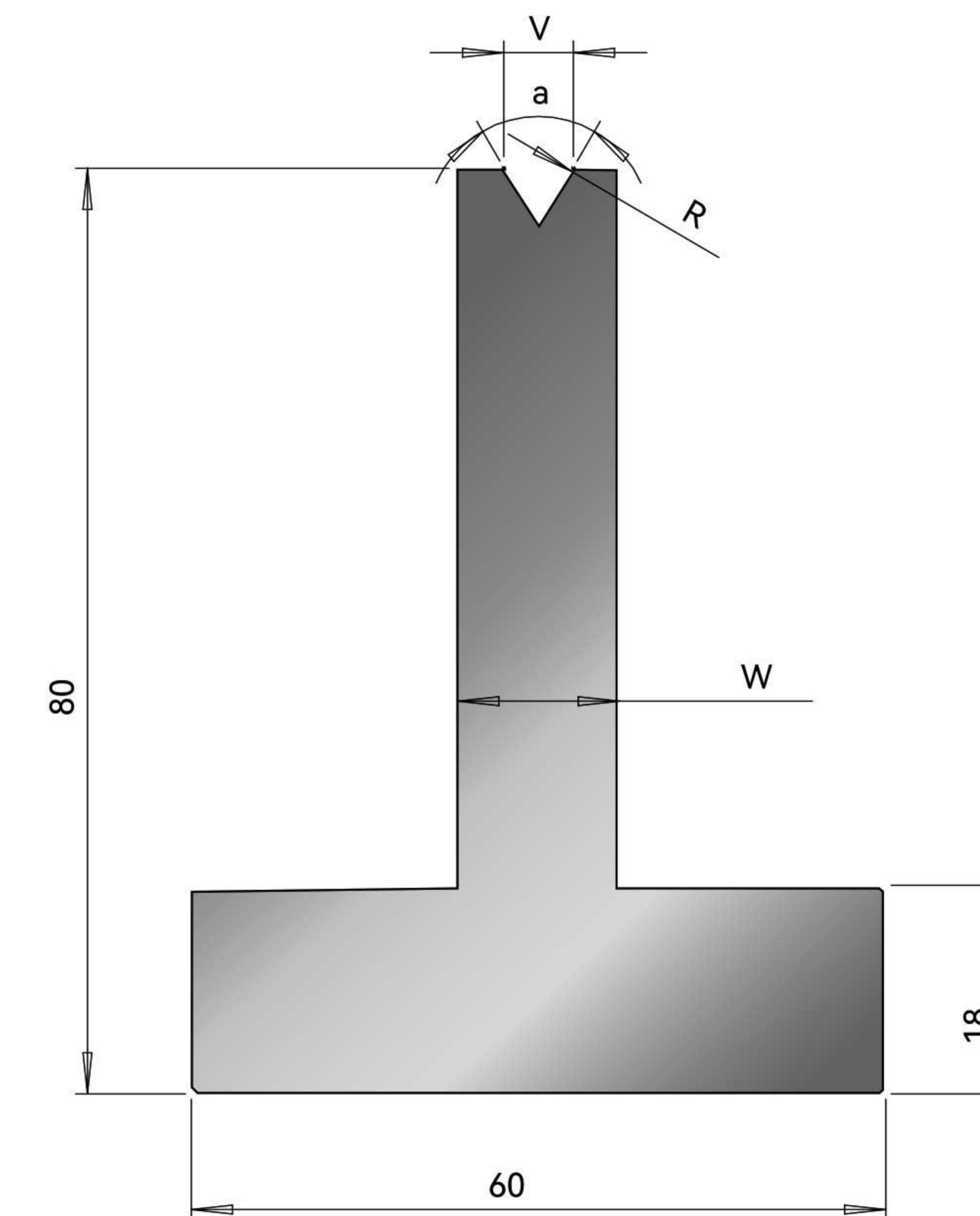

BENDMAX CAT.NO	V	a	R	W	Max Loading (t/m)	Weight(kg/m)
ZED.1VH80.60V6	6	60°	0.5	14	80	15
ZED.1VH80.60V8	8	60°	0.8	14	70	15
ZED.1VH80.60V10	10	60°	0.8	18	80	17
ZED.1VH80.60V12	12	60°	0.8	18	70	17
ZED.1VH80.60V16	16	60°	2.75	24	100	19
ZED.1VH80.60V20	20	60°	3.0	30	100	22
ZED.1VH80.60V25	25	60°	3.0	35	100	23

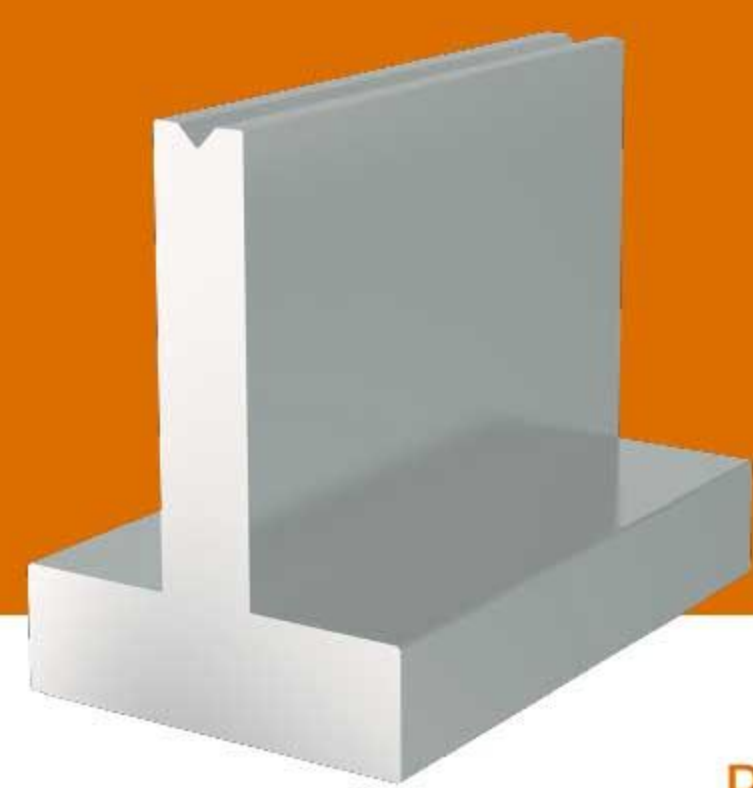

1VH80.88 Die

PRESS BRAKE TOOLS-BENDMAX-EUROPEAN STYLE

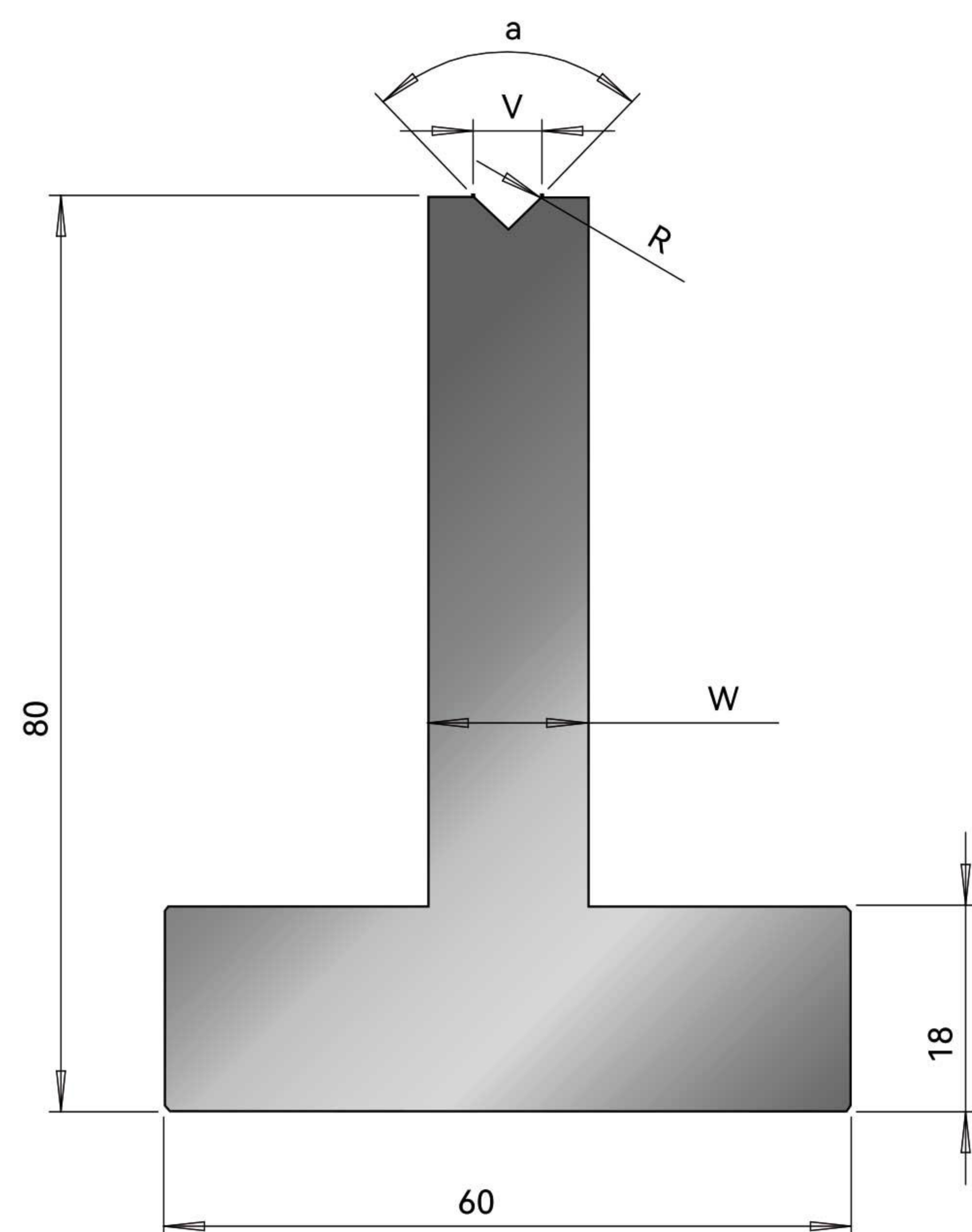

GUNNARPRESS CAT.NO	V	a	R	W	Max Loading (t/m)	Weight(kg/m)
ZED.1VH80.88V6	6	88°	0.4	14	100	15
ZED.1VH80.88V8	8	88°	0.5	14	100	15
ZED.1VH80.88V10	10	88°	0.8	18	100	17
ZED.1VH80.88V12	12	88°	2.75	18	100	17
ZED.1VH80.88V16	16	88°	2.75	24	100	20
ZED.1VH80.88V20	20	88°	3.0	30	100	22
ZED.1VH80.88V25	25	88°	3.0	35	100	24

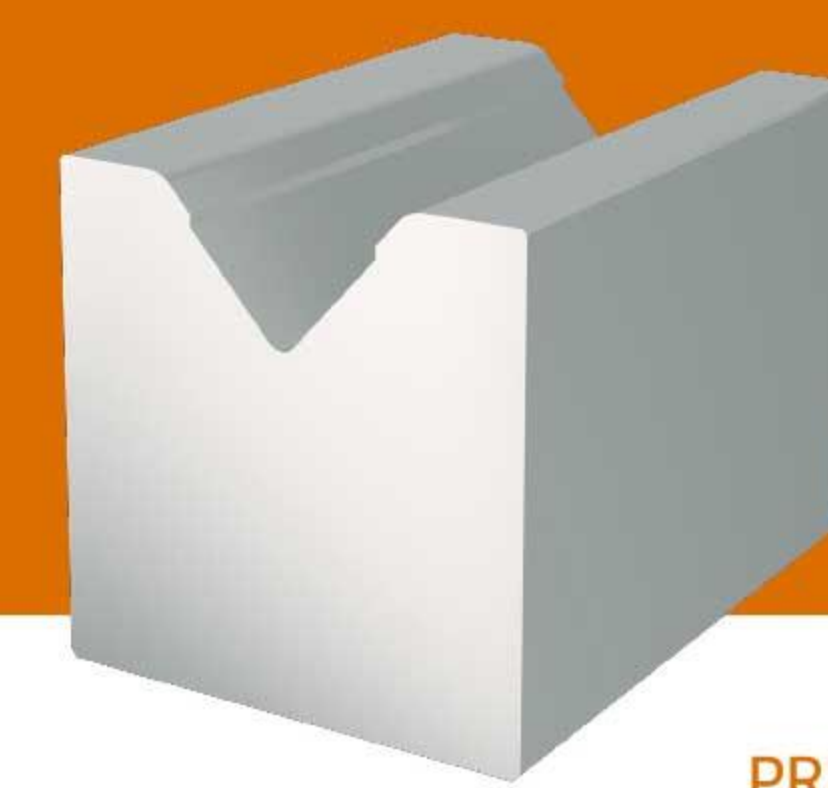

1VLarge Die

PRESS BRAKE TOOLS-BENDMAX-EUROPEAN STYLE

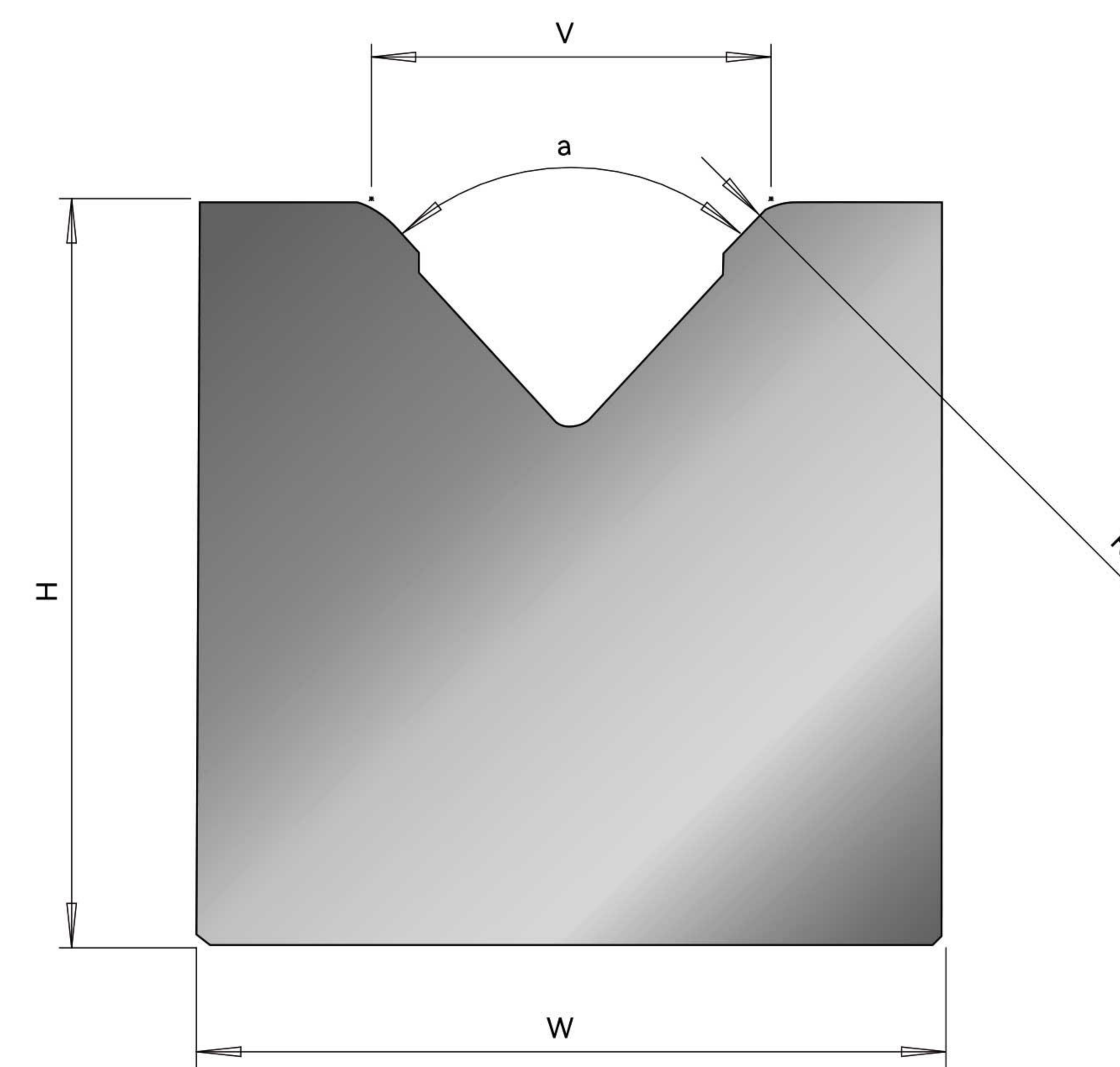

GUNNARPRESS CAT.NO	V	a	R	W	H	Max Loading (t/m)	Weight(kg/m)
ZED.1V.LG.85V32	32	85°	4.0	60	60	100	27
ZED.1V.LG.85V40	40	85°	4.0	60	60	100	23
ZED.1V.LG.85V50	50	85°	4.0	60	60	100	23
ZED.1V.LG.85V63	63	85°	5.0	75	80	100	34
ZED.1V.LG.85V80	80	85°	6.0	95	95	100	49
ZED.1V.LG.85V100	100	85°	7.0	110	120	100	69



2VH46.0407 Die

PRESS BRAKE TOOLS-BENDMAX-EUROPEAN STYLE

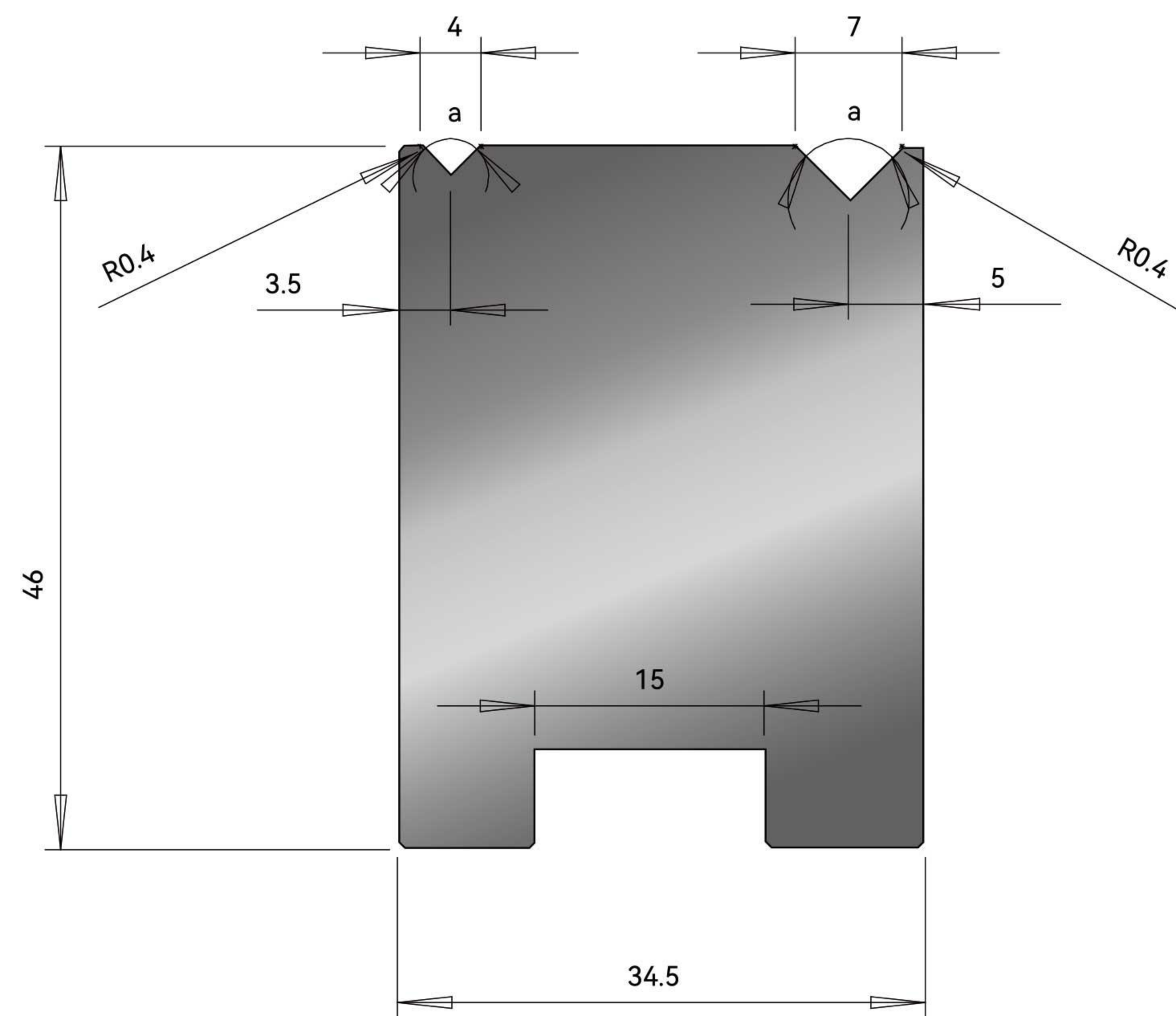

2VH46.0610 Die

PRESS BRAKE TOOLS-BENDMAX-EUROPEAN STYLE

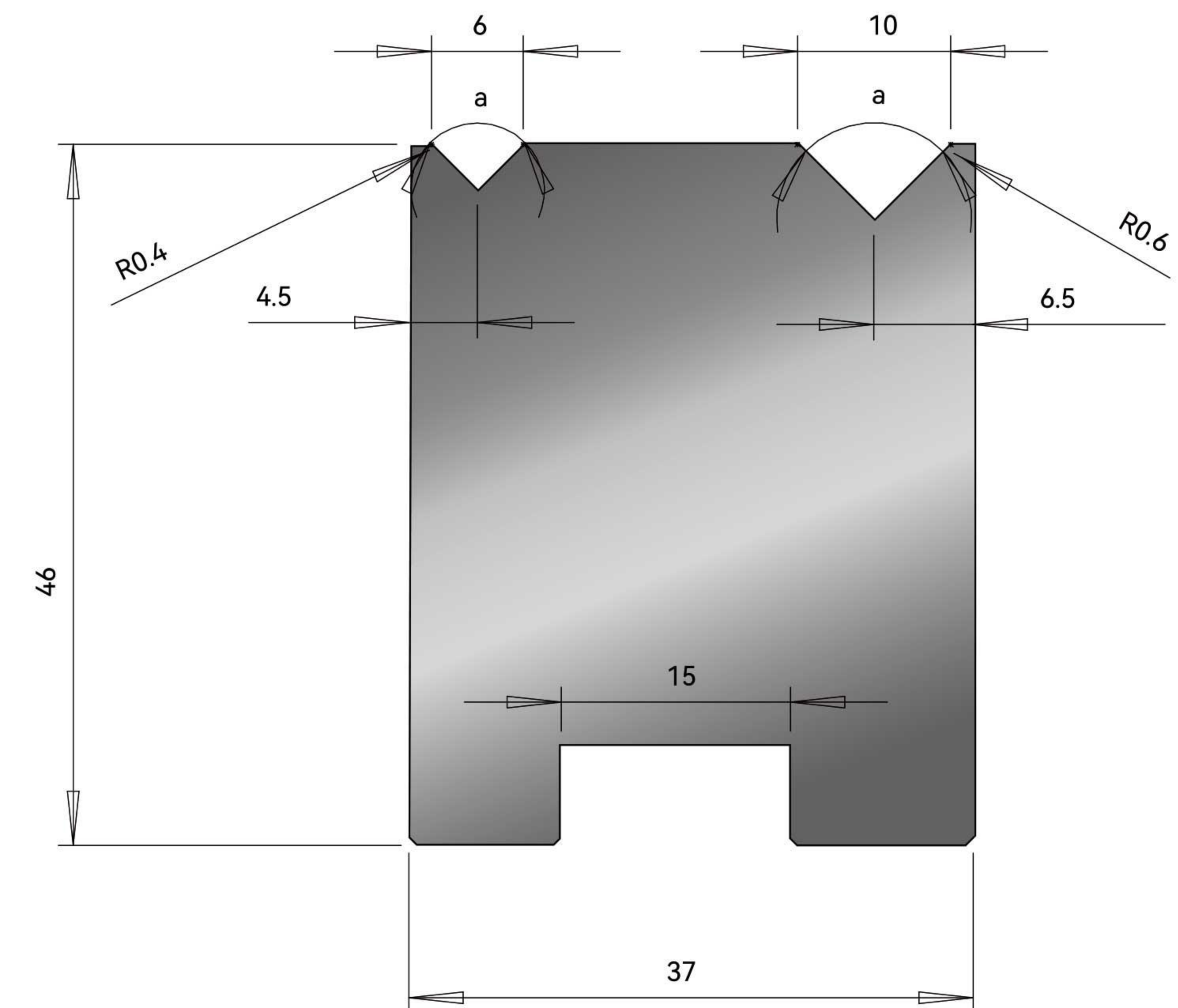

BENDMAX CAT.NO	a	Max Loading (t/m)	Weight(kg/m)
ZED.2VH46.880407	88°	60	12
ZED.2VH46.900407	90°	60	12

BENDMAX CAT.NO	a	Max Loading (t/m)	Weight(kg/m)
ZED.2VH46.880610	88°	70	12
ZED.2VH46.900610	90°	70	12

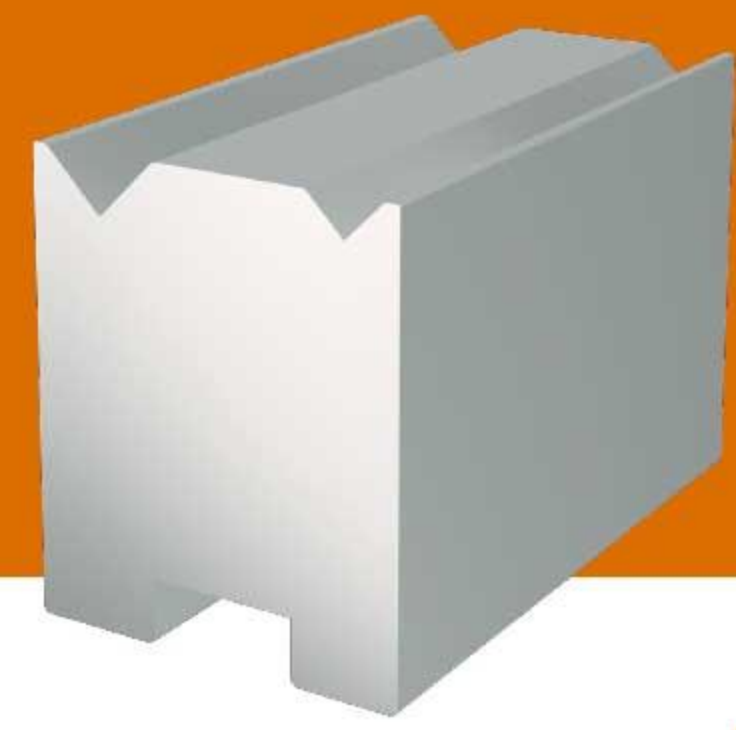

2VH46.0812 Die

PRESS BRAKE TOOLS-BENDMAX-EUROPEAN STYLE

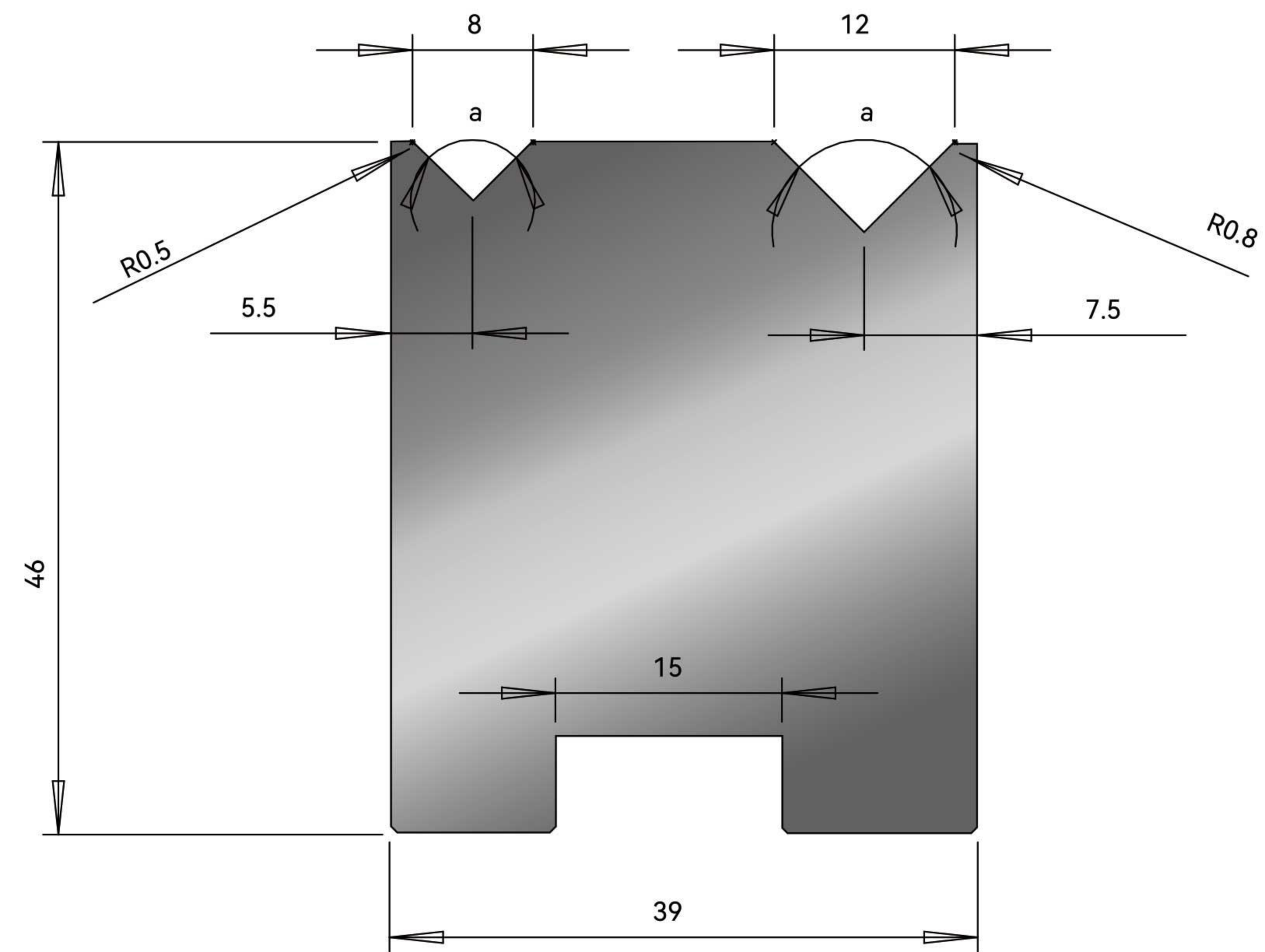

BENDMAX CAT.NO	a	Max Loading (t/m)	Weight(kg/m)
ZED.2VH46.880812	88°	80	13
ZED.2VH46.900812	90°	80	13

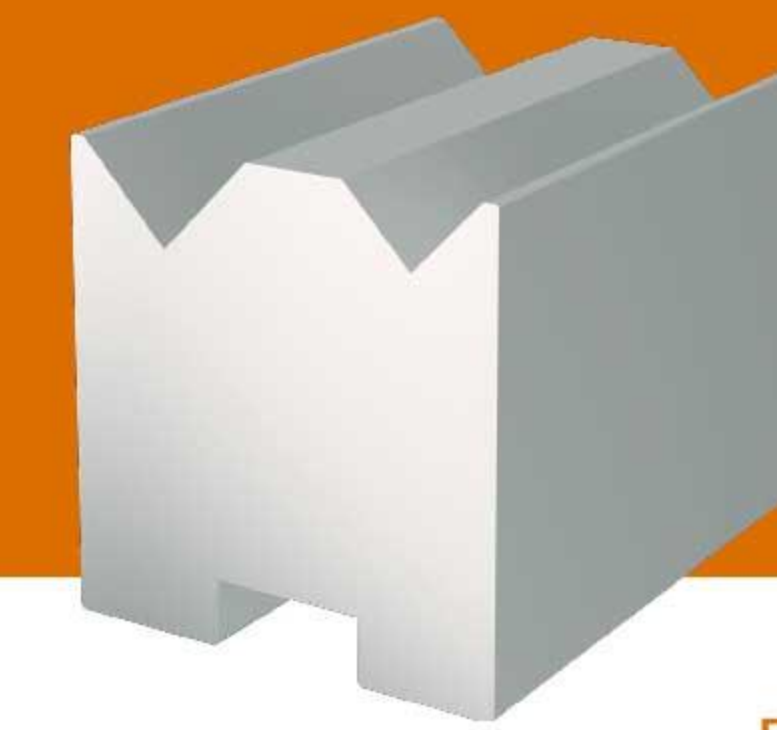

2VH46.1418 Die

PRESS BRAKE TOOLS-BENDMAX-EUROPEAN STYLE

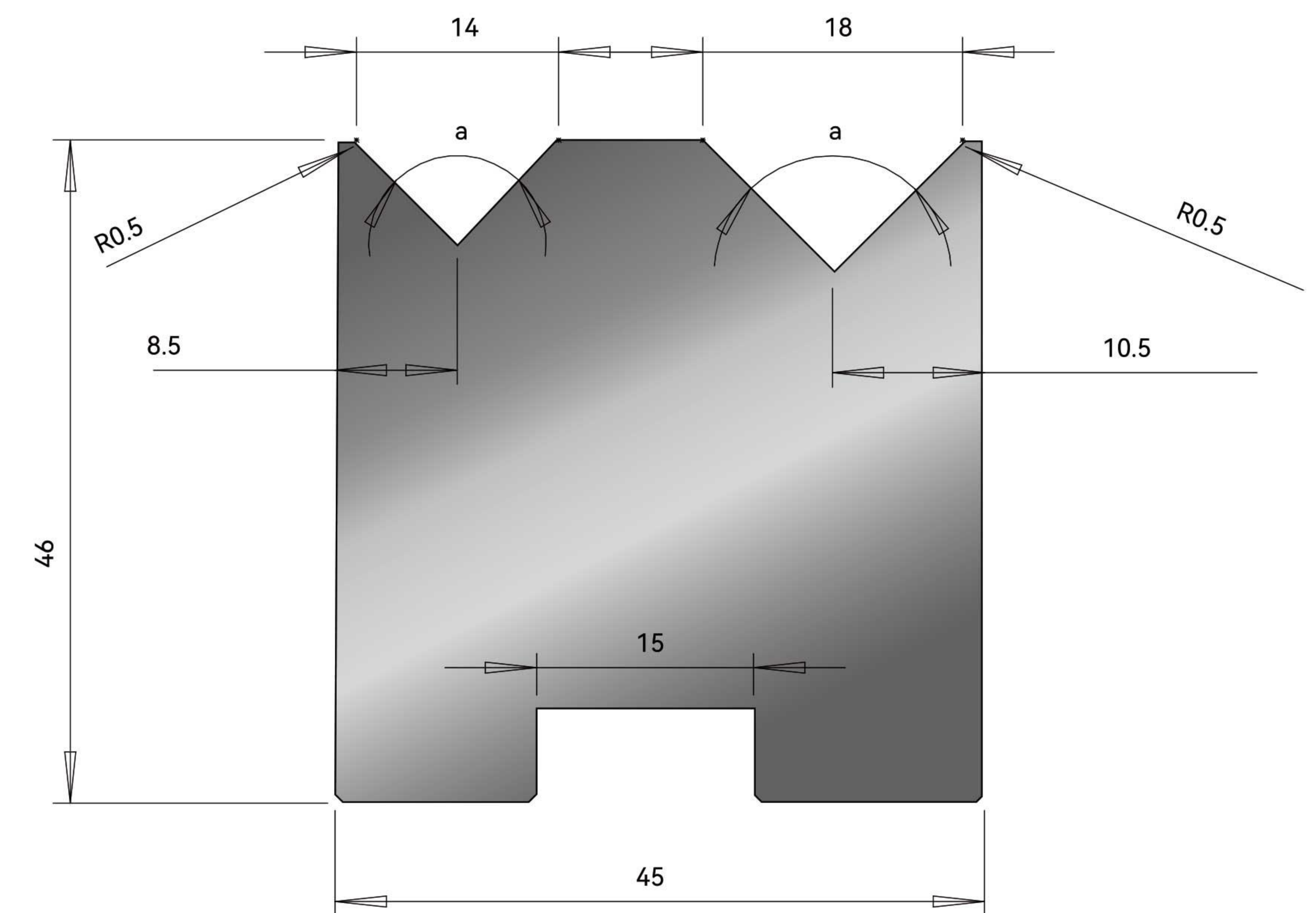

BENDMAX CAT.NO	a	Max Loading (t/m)	Weight(kg/m)
ZED.2VH46.881416	88°	100	15
ZED.2VH46.901416	90°	100	15



2VH46.1220 Die

PRESS BRAKE TOOLS-BENDMAX-EUROPEAN STYLE

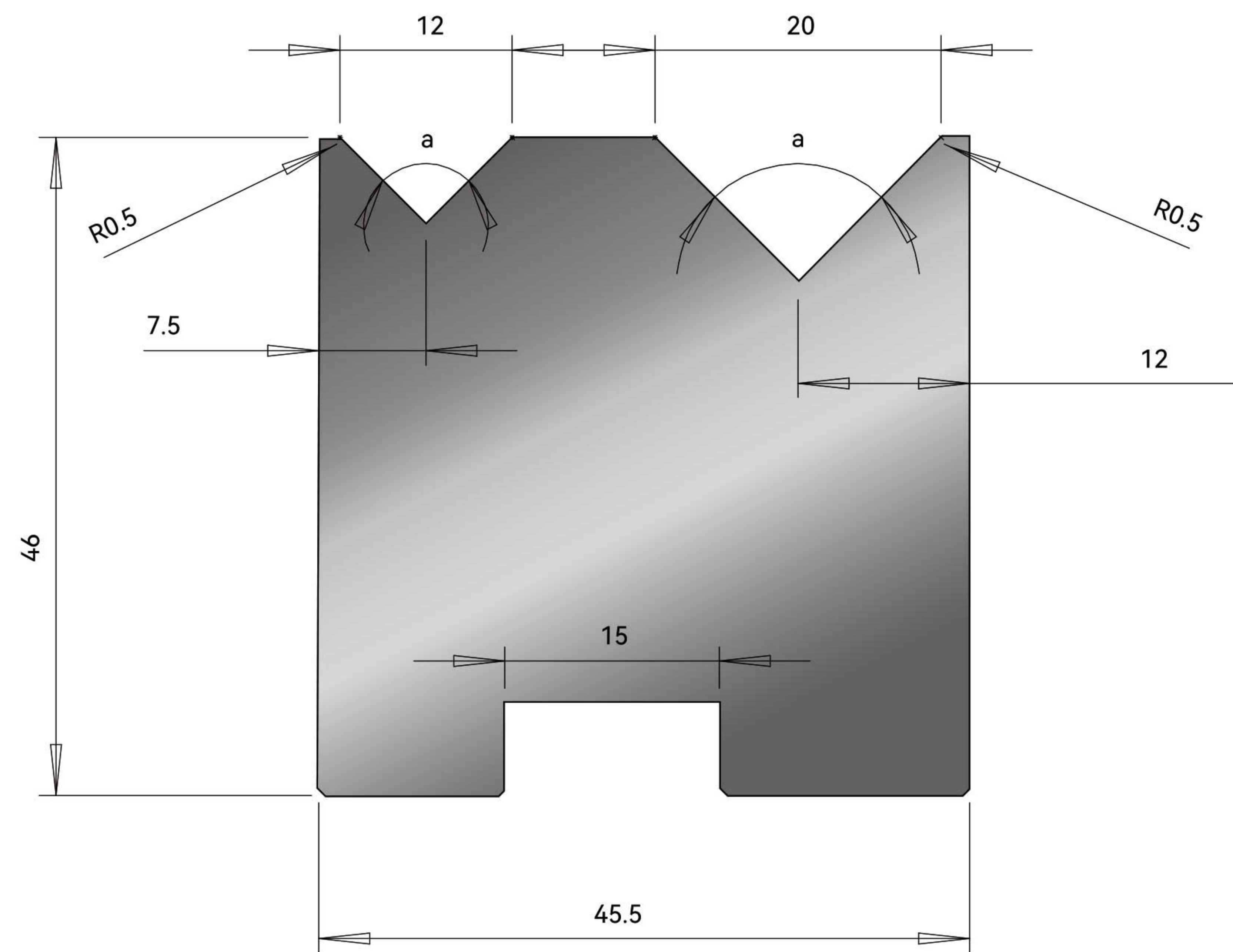

2VH46.1625 Die

PRESS BRAKE TOOLS-BENDMAX-EUROPEAN STYLE

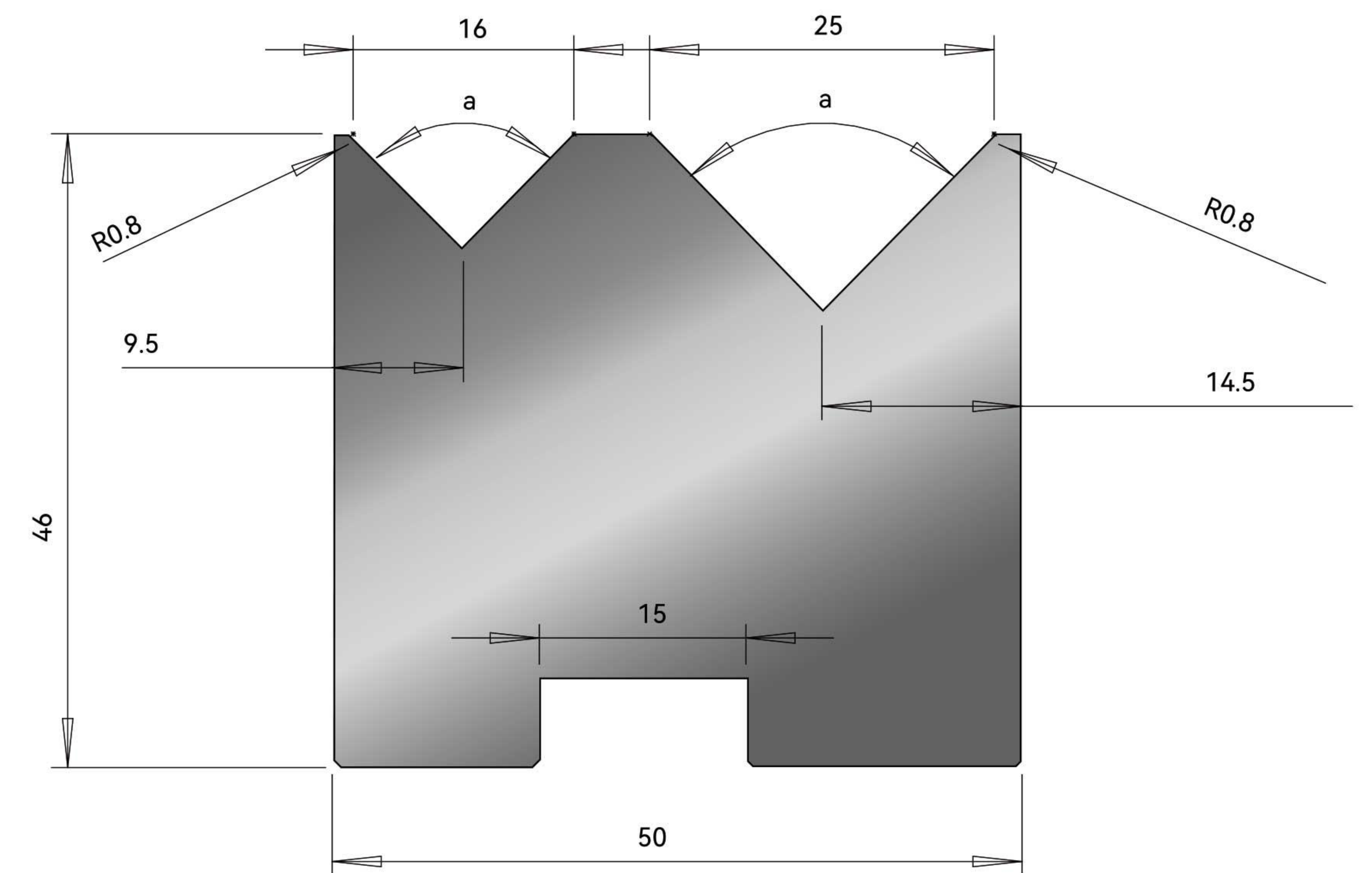

BENDMAX CAT.NO	a	Max Loading (t/m)	Weight(kg/m)
ZED.2VH46.881220	88°	100	15

BENDMAX CAT.NO	a	Max Loading (t/m)	Weight(kg/m)
ZED.2VH46.881625	88°	100	15



2VH46.750620 Die

PRESS BRAKE TOOLS-BENDMAX-EUROPEAN STYLE

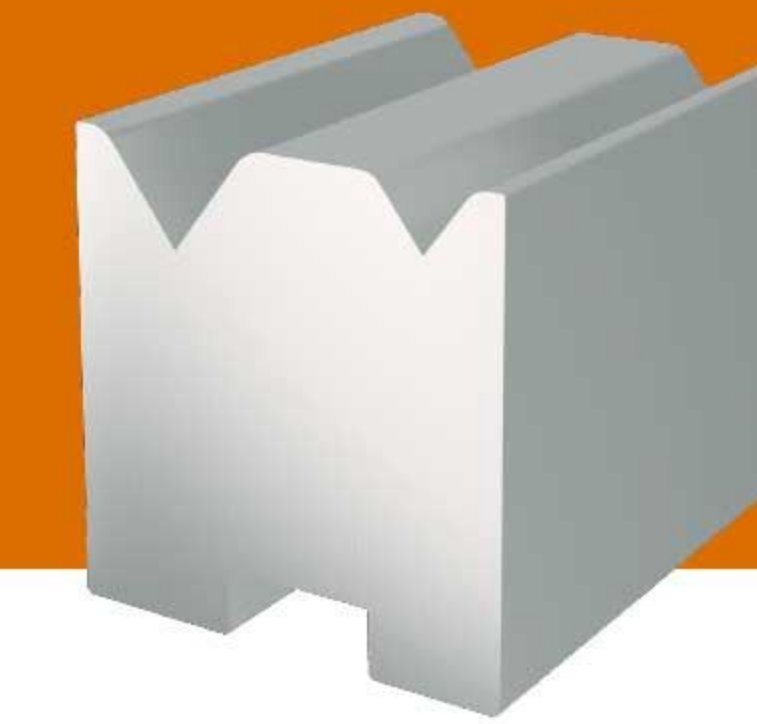
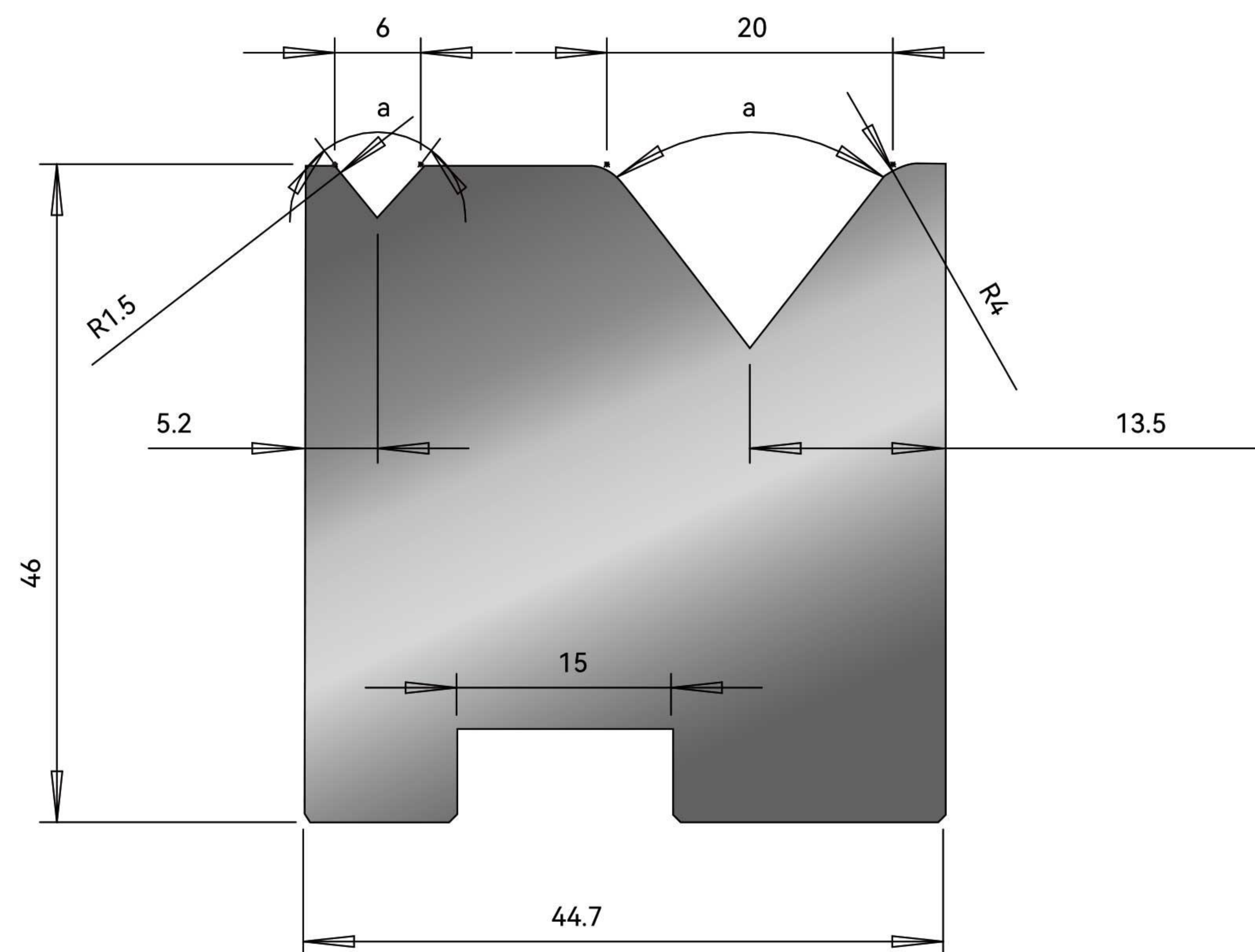

2VH46.751016 Die

PRESS BRAKE TOOLS-BENDMAX-EUROPEAN STYLE

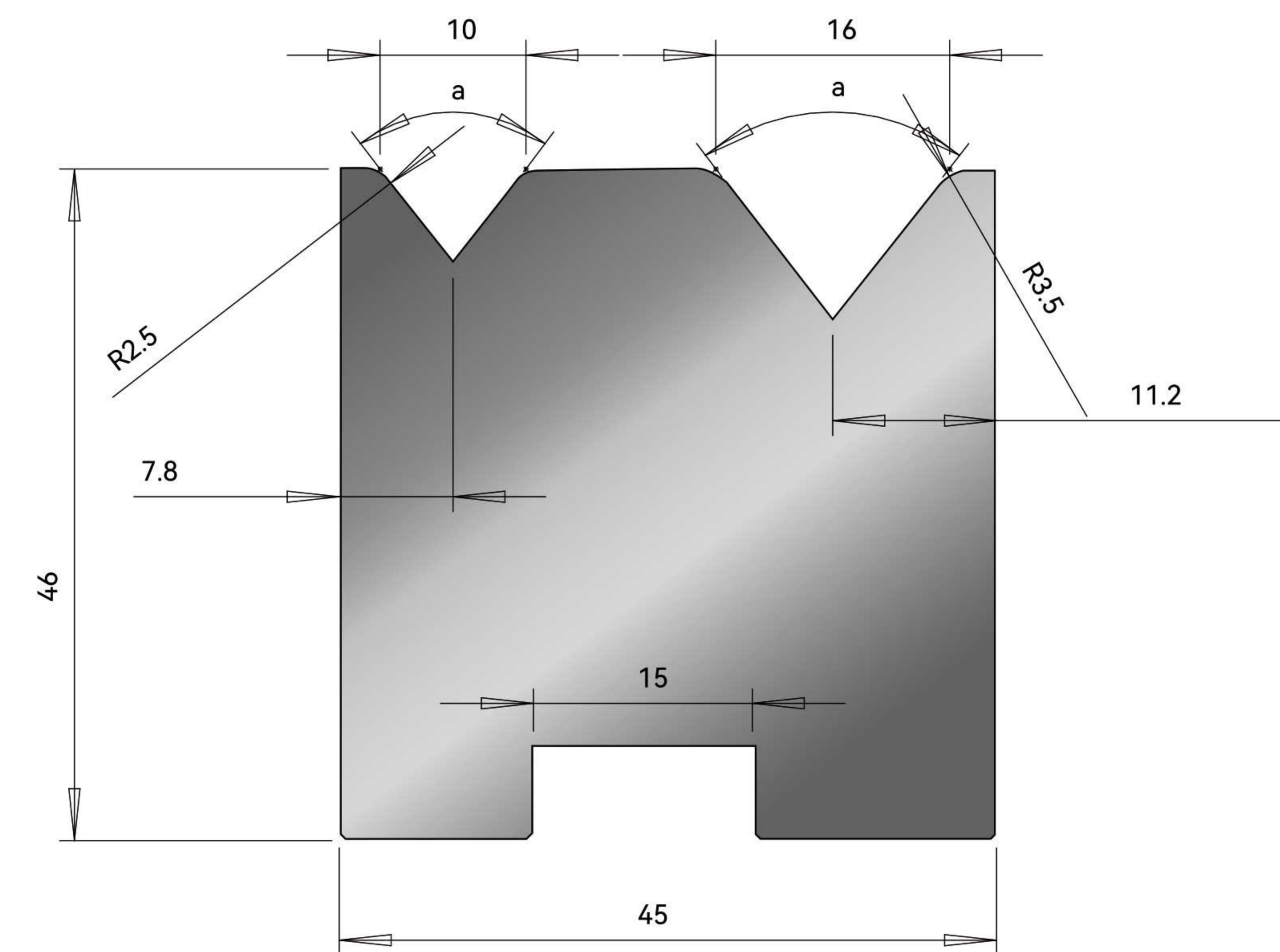

BENDMAX CAT.NO	a	Max Loading (t/m)	Weight(kg/m)
ZED.2VH46.750620	75°	100	15

BENDMAX CAT.NO	a	Max Loading (t/m)	Weight(kg/m)
ZED.2VH46.751016	75°	100	15



2VH46.751022 Die

PRESS BRAKE TOOLS-BENDMAX-EUROPEAN STYLE

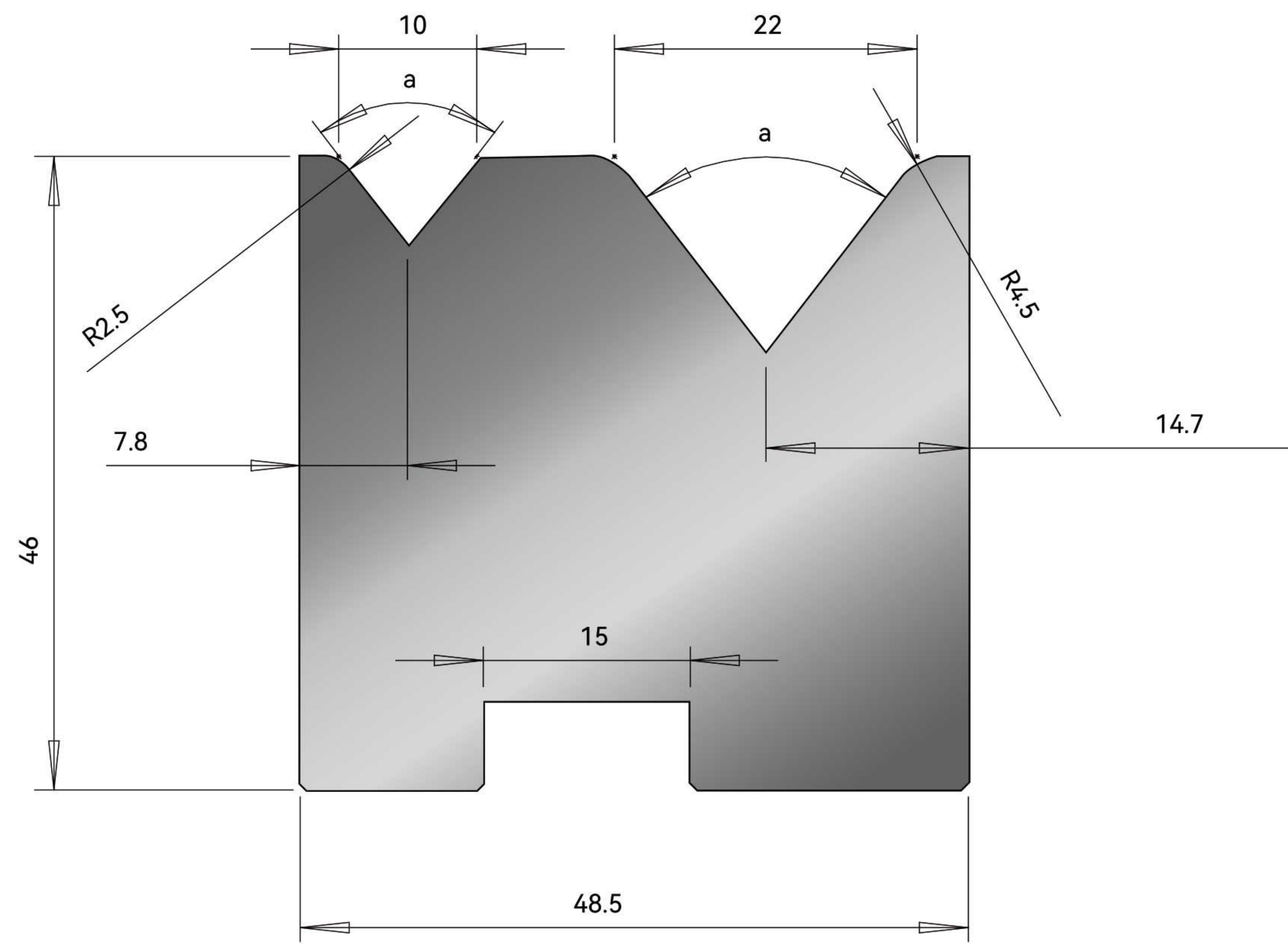

BENDMAX CAT.NO	a	Max Loading (t/m)	Weight(kg/m)
ZED.2VH46.751022	75°	100	15



2VH46.300610 Die

PRESS BRAKE TOOLS-BENDMAX-EUROPEAN STYLE

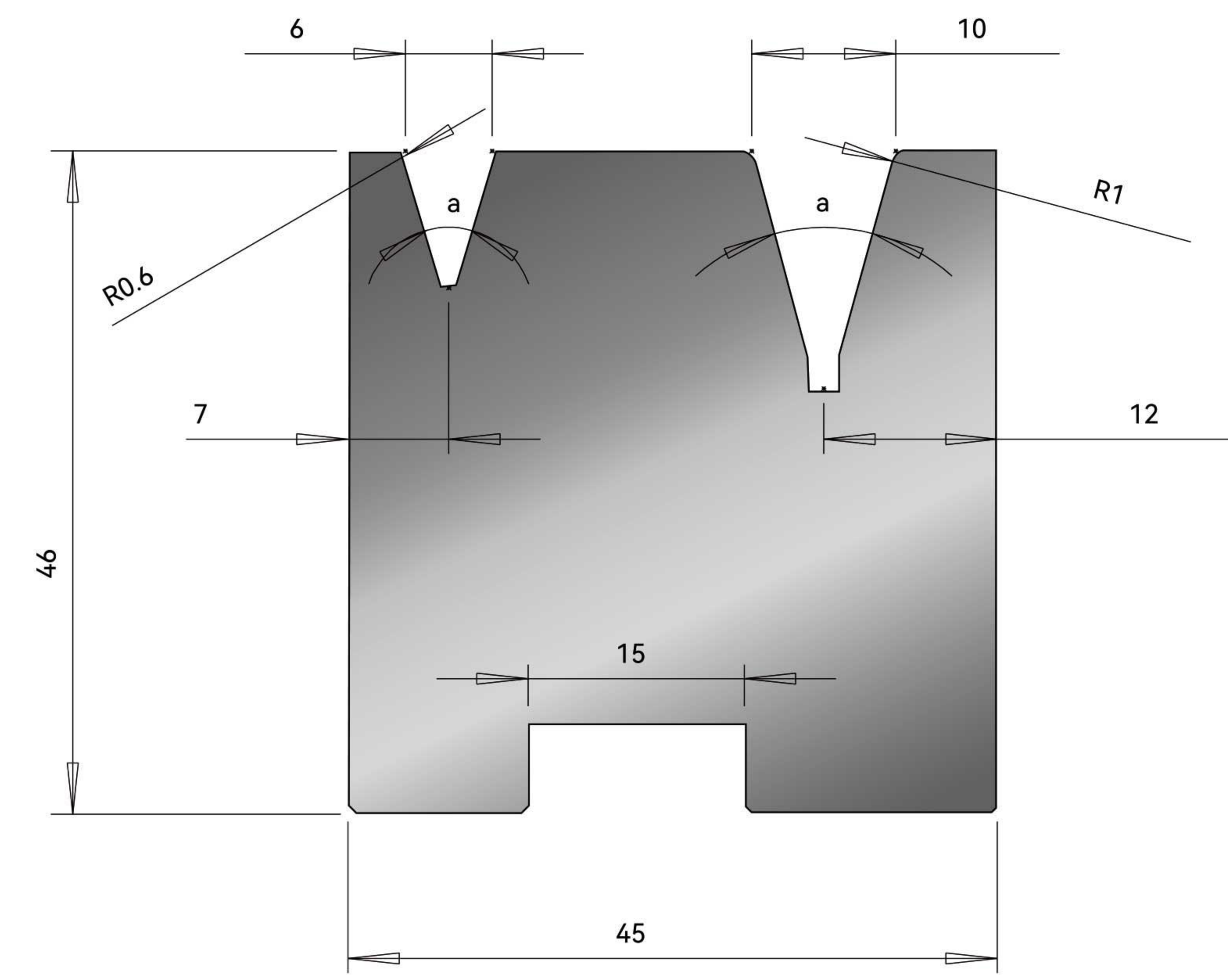

BENDMAX CAT.NO	a	Max Loading (t/m)	Weight(kg/m)
ZED.2VH46.300610	30°	40	15

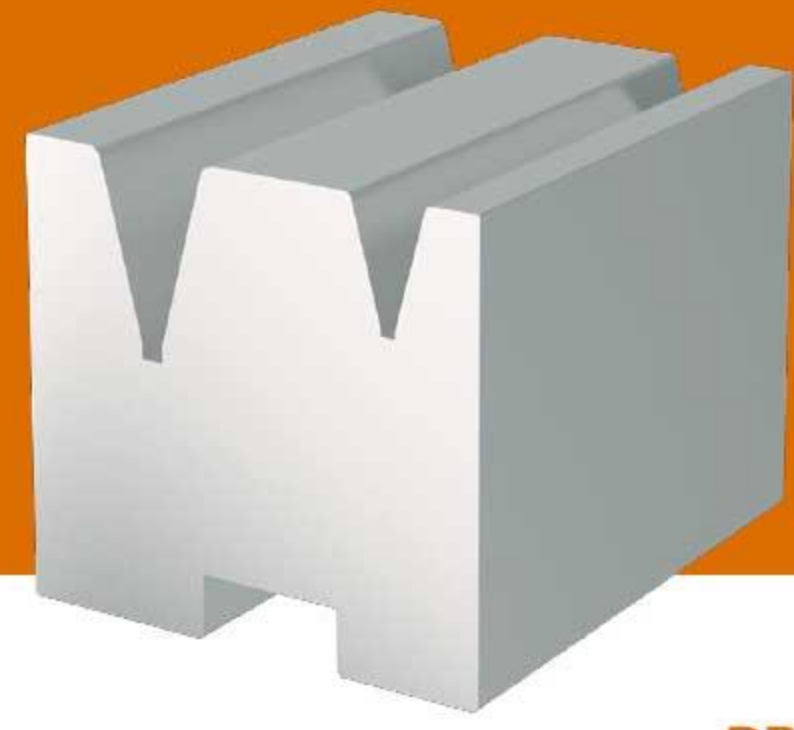

2VH46.300812 Die

PRESS BRAKE TOOLS-BENDMAX-EUROPEAN STYLE

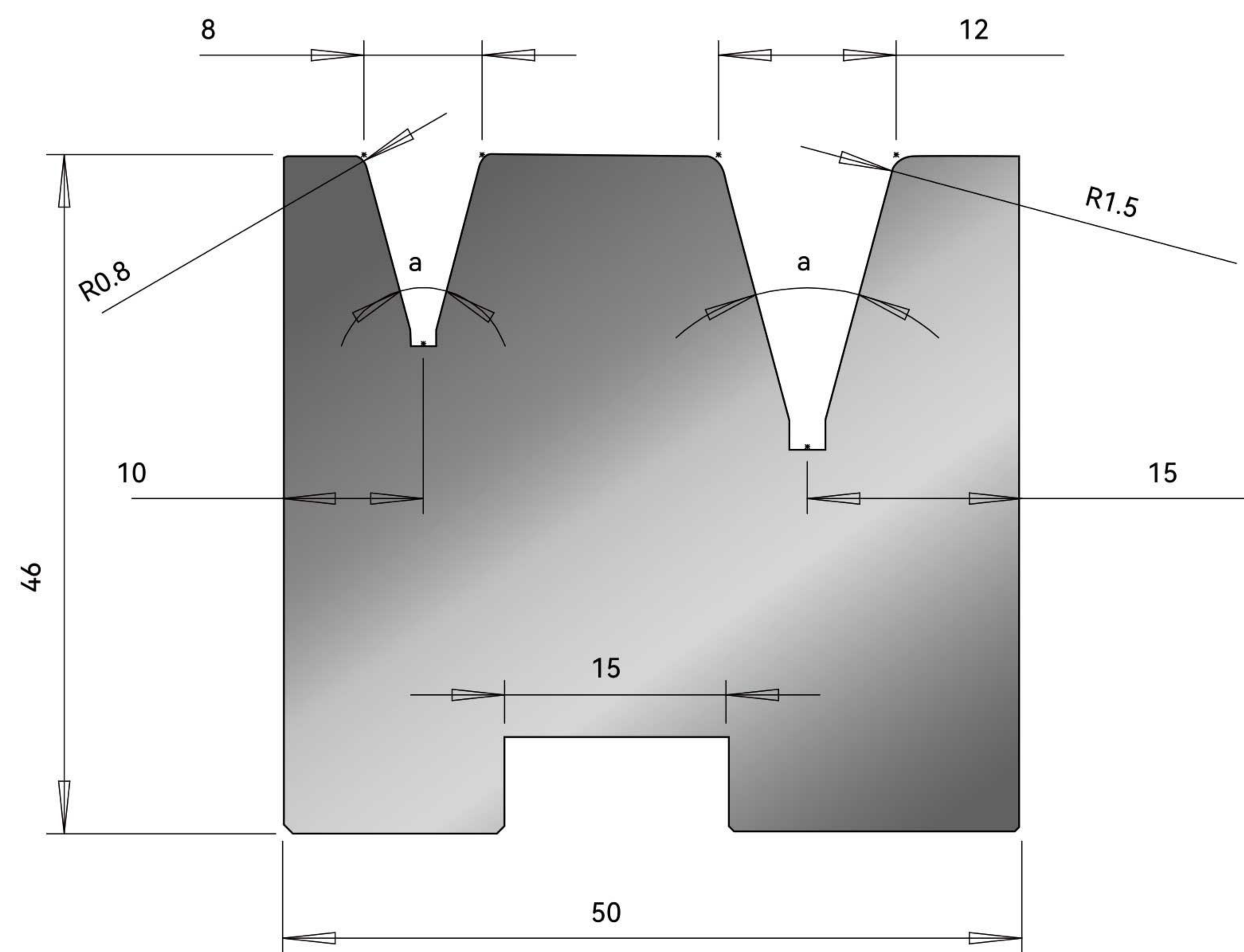

BENDMAX CAT.NO	a	Max Loading (t/m)	Weight(kg/m)
ZED.2VH46.300812	30°	40	16



Die AP

PRESS BRAKE TOOLS-BENDMAX-EUROPEAN STYLE

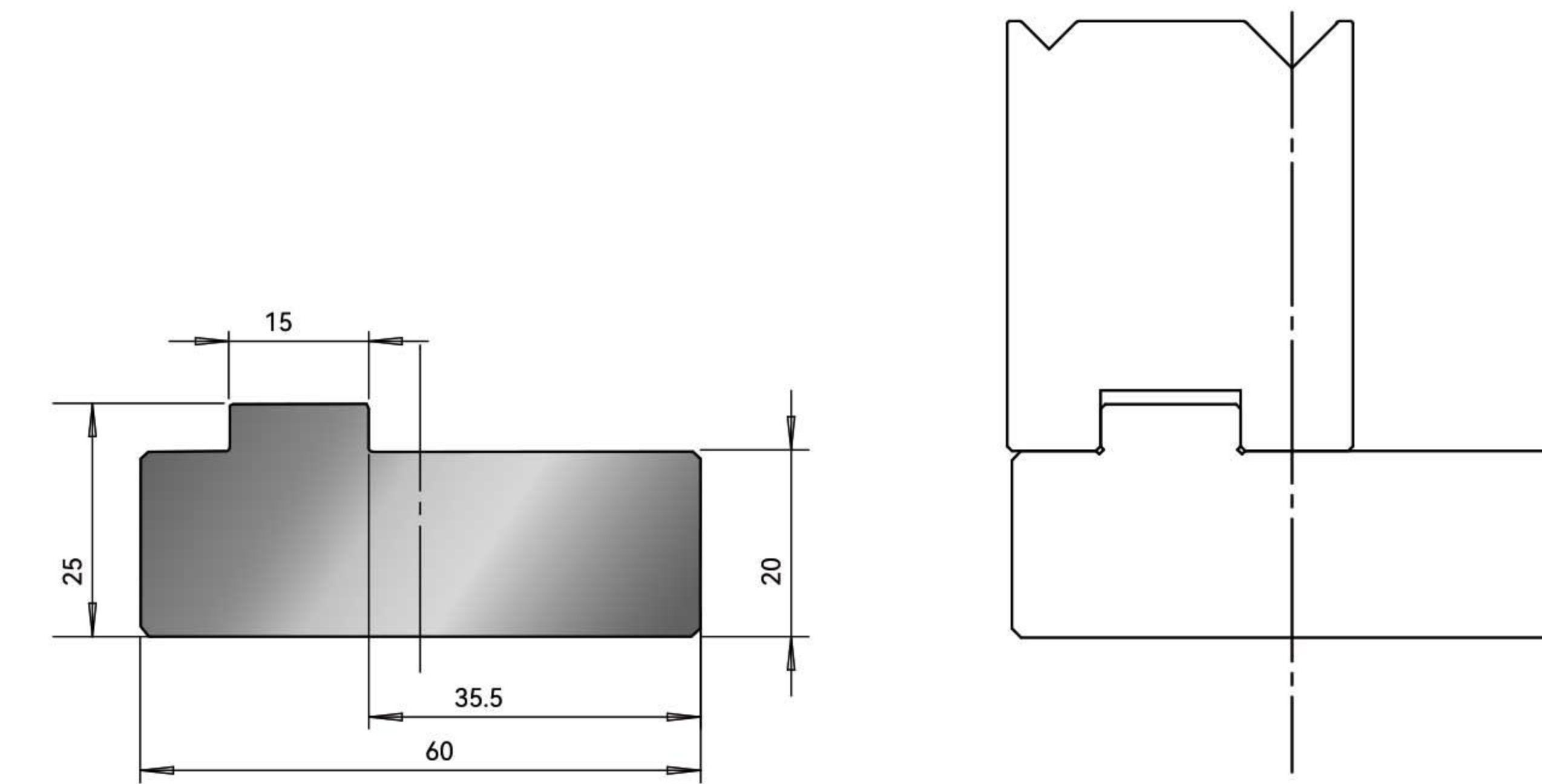

BENDMAX CAT.NO	Max Loading (t/m)	Weight(kg/m)
Die AP60	100	10

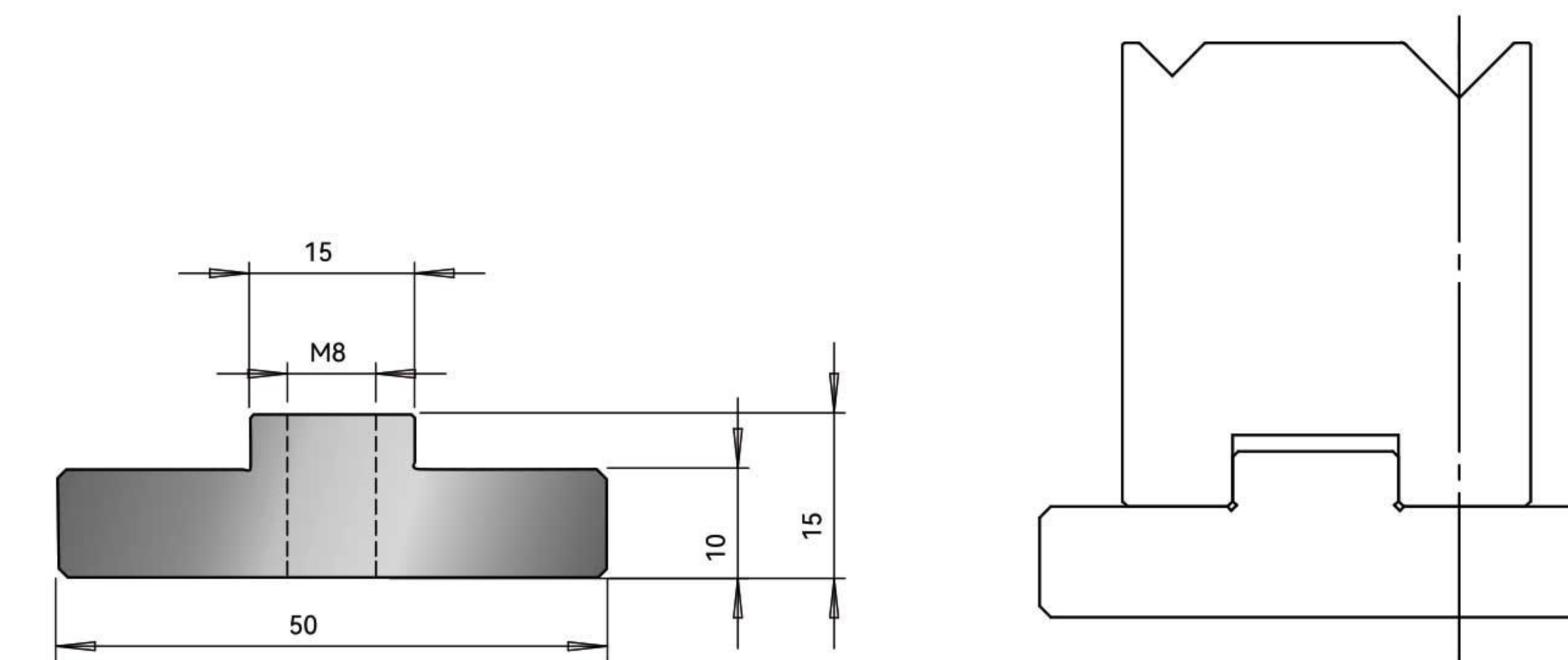

BENDMAX CAT.NO	Max Loading (t/m)	Weight(kg/m)
Die AP50	100	10

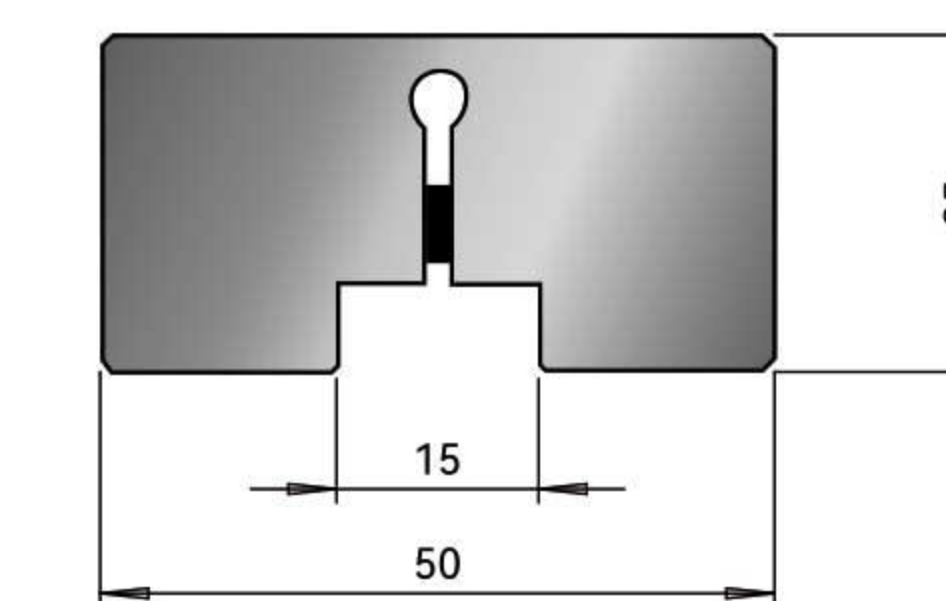

BENDMAX CAT.NO	Weight(kg/m)
RAIL CLAMP	0.2

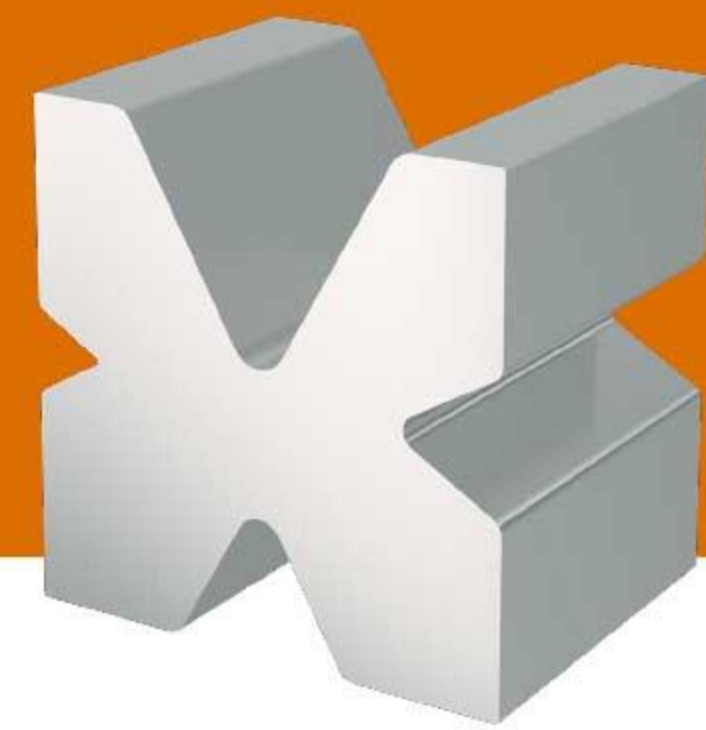

4VM60 Die

PRESS BRAKE TOOLS-BENDMAX-EUROPEAN STYLE

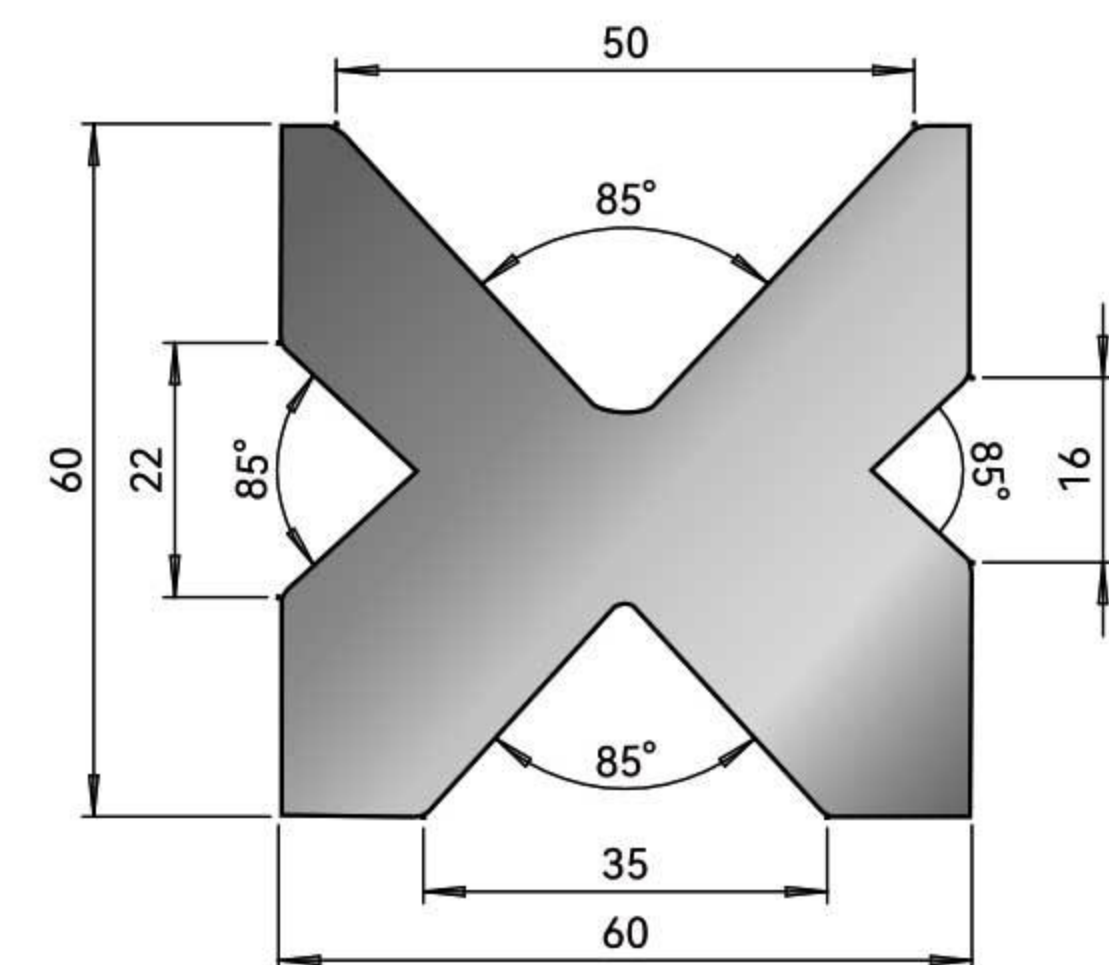

BENDMAX CAT.NO	V16	V22	V35	V50	Max Loading (t/m)	Weight(kg/m)
ZED.4VM60.85	R2	R2	R2	R3	100	19

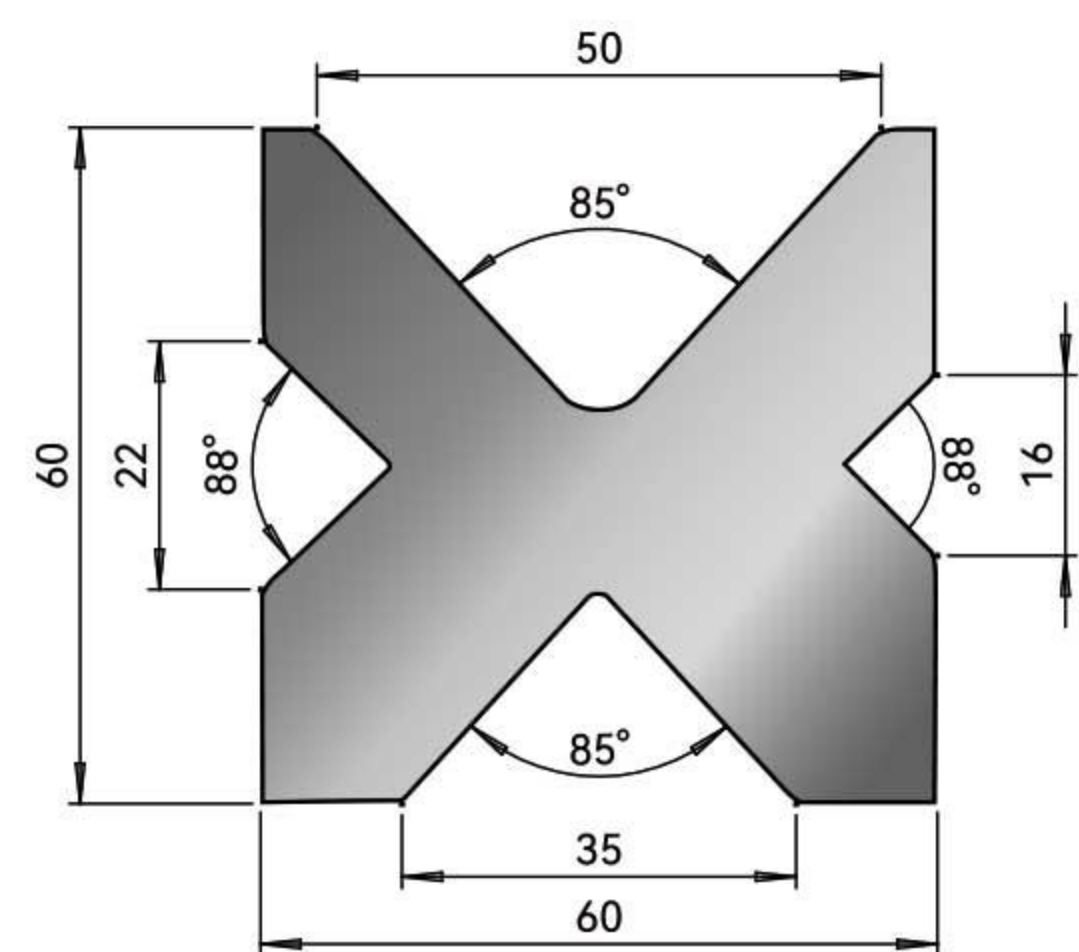

BENDMAX CAT.NO	V16	V22	V35	V50	Max Loading (t/m)	Weight(kg/m)
ZED.4VM60.8588	R2	R2	R2	R3	100	19

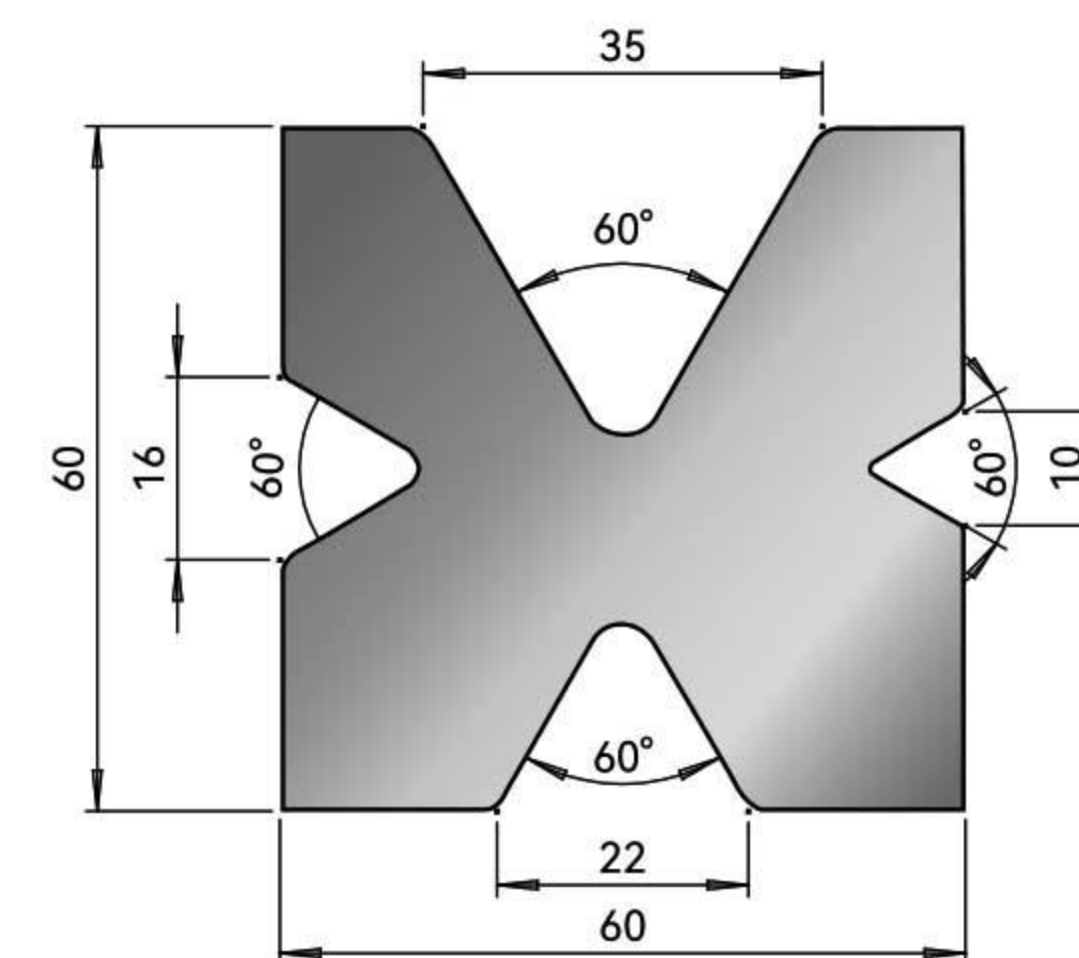

BENDMAX CAT.NO	V16	V22	V35	V50	Max Loading (t/m)	Weight(kg/m)
ZED.4VM60.60	R2	R2	R2	R3	60	21

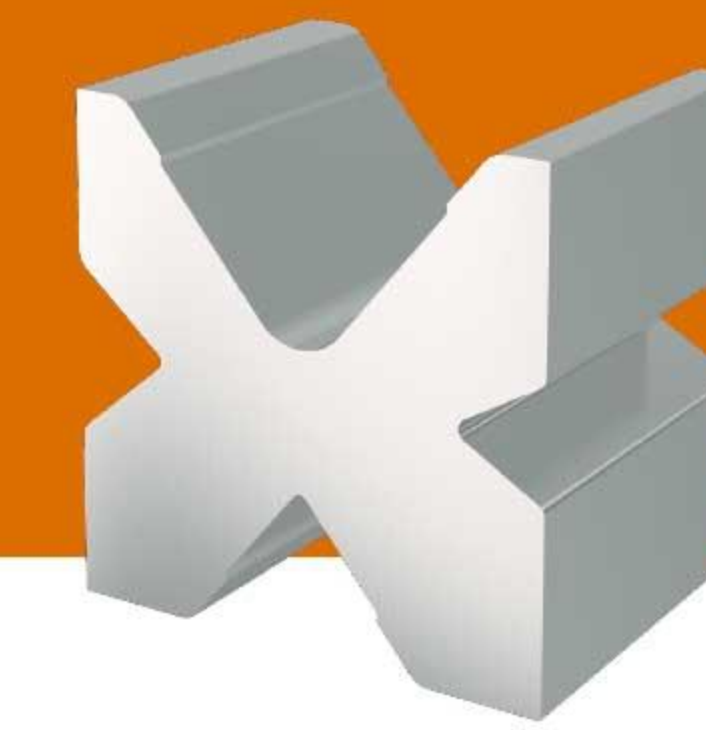

4VM90 Die

PRESS BRAKE TOOLS-BENDMAX-EUROPEAN STYLE

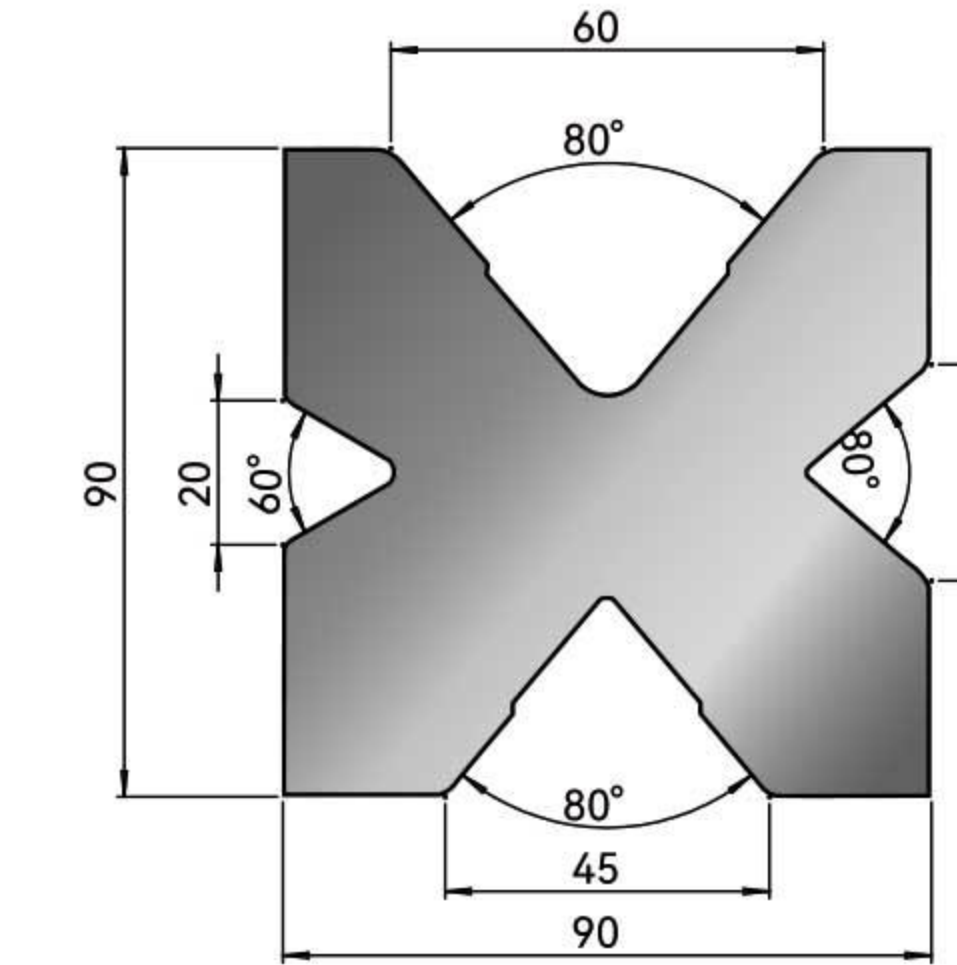

BENDMAX CAT.NO	V16	V22	V35	V50	Max Loading (t/m)	Weight(kg/m)
ZED.4VM90.6080	R2	R4	R4	R5	60	43

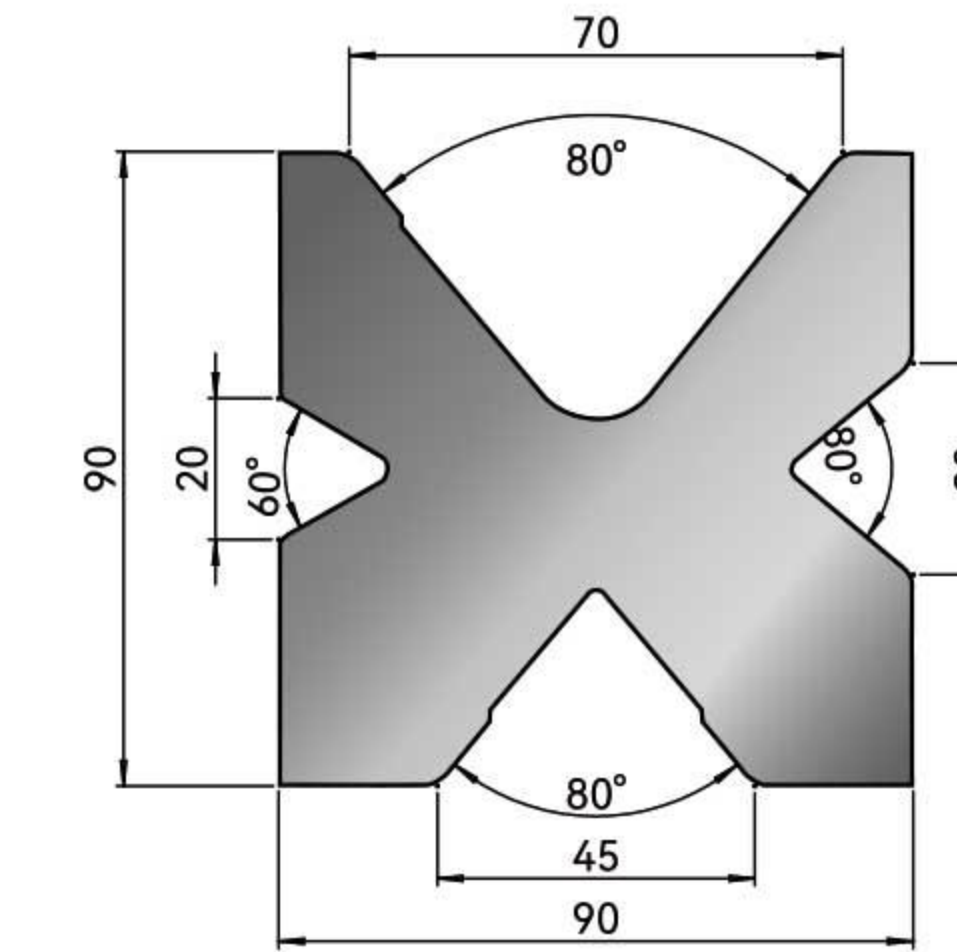

BENDMAX CAT.NO	V16	V22	V35	V50	Max Loading (t/m)	Weight(kg/m)
ZED.4VM90.6080	R2	R4	R4	R5	100	46



Offest Z Bending

PRESS BRAKE TOOLS-BENDMAX-EUROPEAN STYLE

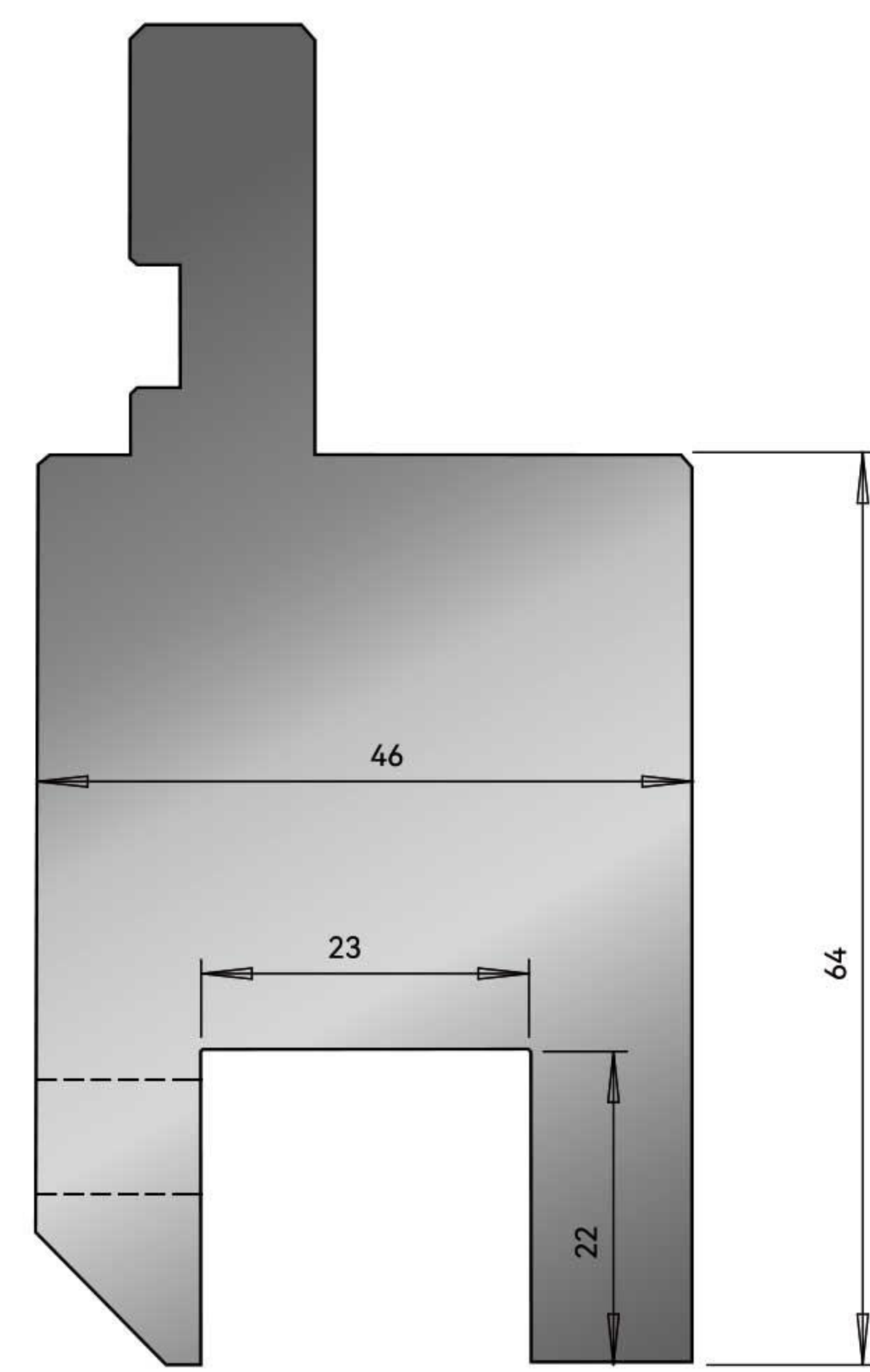

ZEZPH

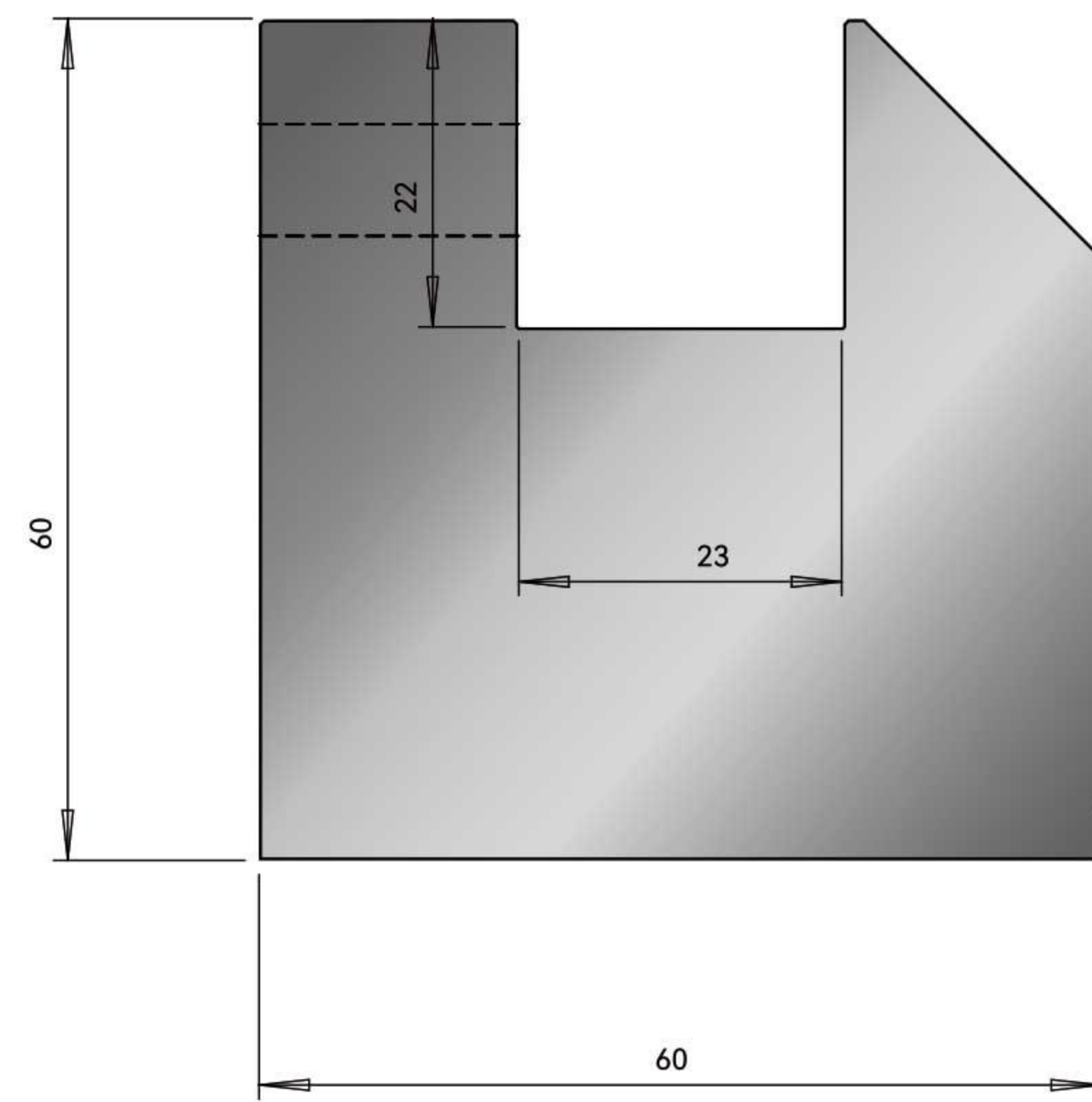

ZEZDH

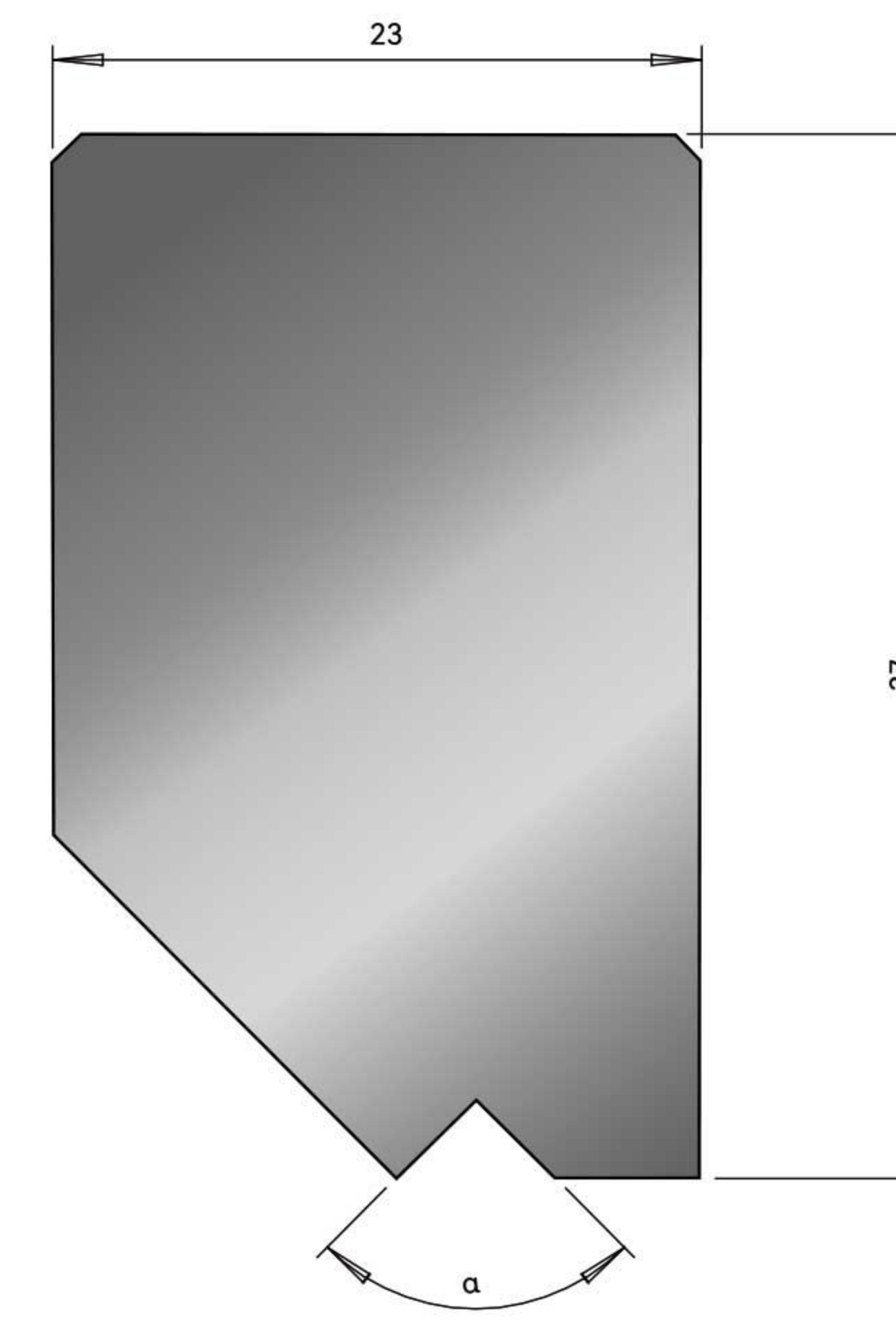

ZEZIN-90

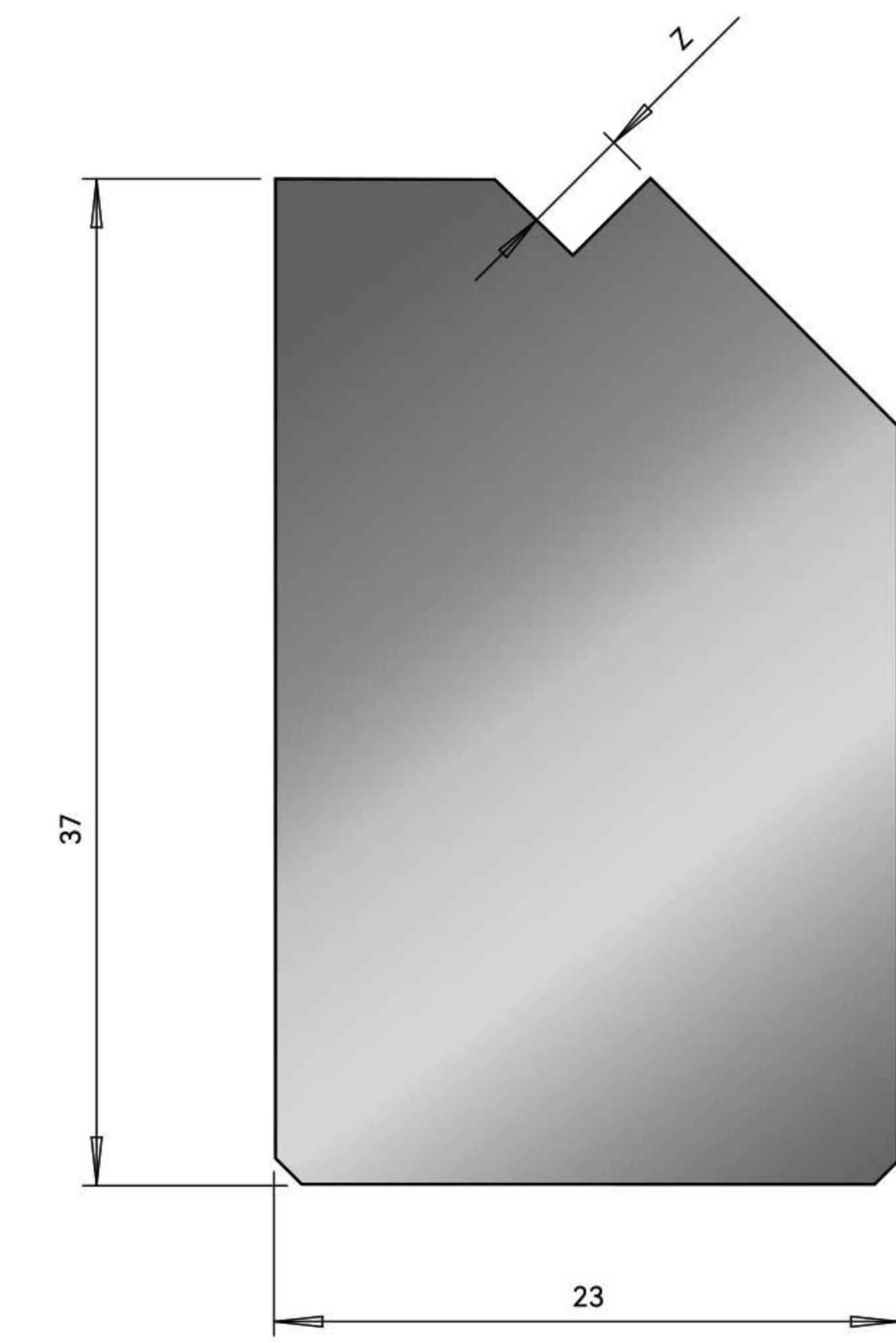

ZEZIN-90

BENDMAX CAT.NO	Length	Max Loading (t/m)	Weight(kg/m)
ZEZPH	835	100	22
ZEZDH	835	100	23

BENDMAX CAT.NO	Length	a	Z	Max Loading (t/m)	Weight(kg/m)
ZEZIN-90/Z3	835	90°	3	100 (α=90°)	13
ZEZIN-90/Z4	835	90°	4	100 (α=90°)	13
ZEZIN-90/Z5	835	90°	5	100 (α=90°)	13
ZEZIN-90/Z6	835	90°	6	100 (α=90°)	13
ZEZIN-90/Z7	835	90°	7	100 (α=90°)	13
ZEZIN-90/Z8	835	90°	8	100 (α=90°)	13



Radius Tool

PRESS BRAKE TOOLS-BENDMAX-EUROPEAN STYLE



Hemming Tool

PRESS BRAKE TOOLS-BENDMAX-EUROPEAN STYLE

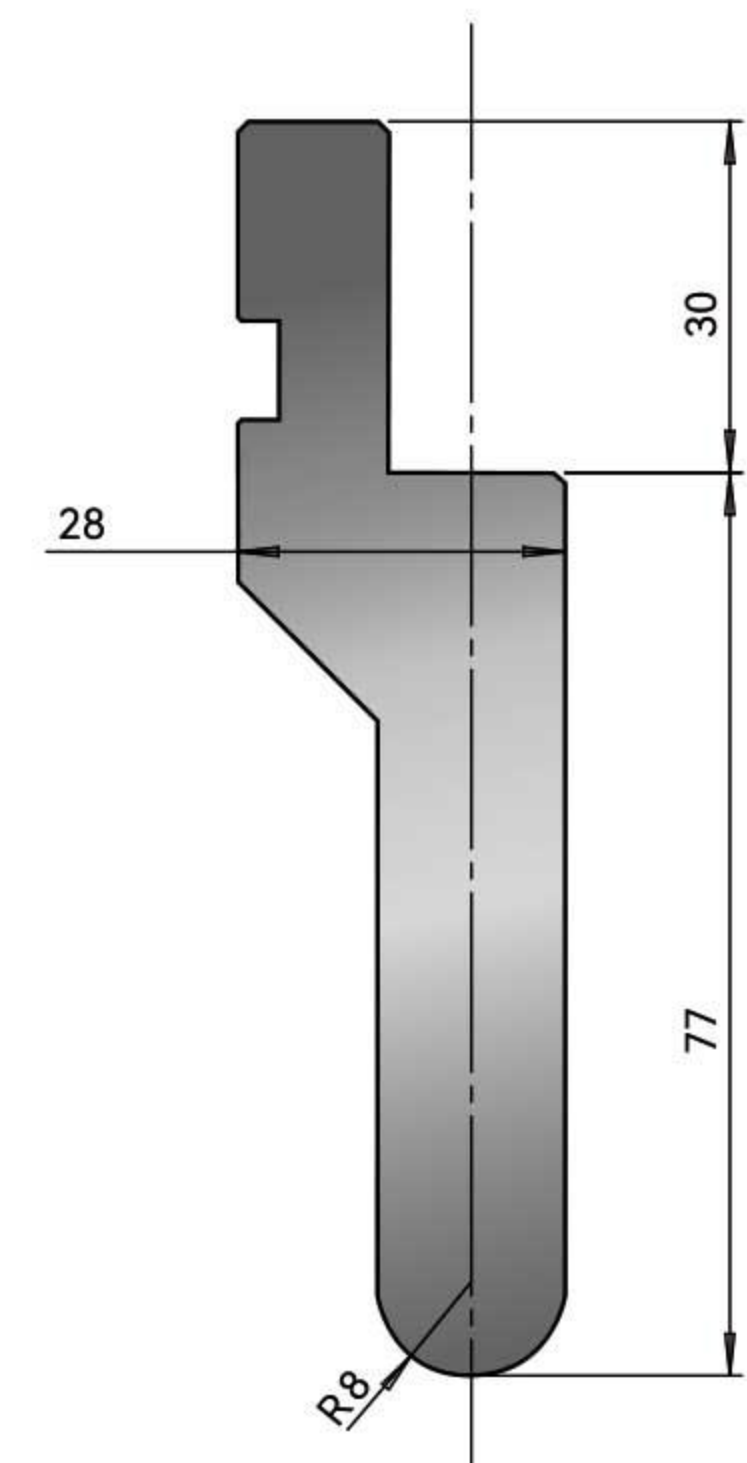

ZEP.RD08

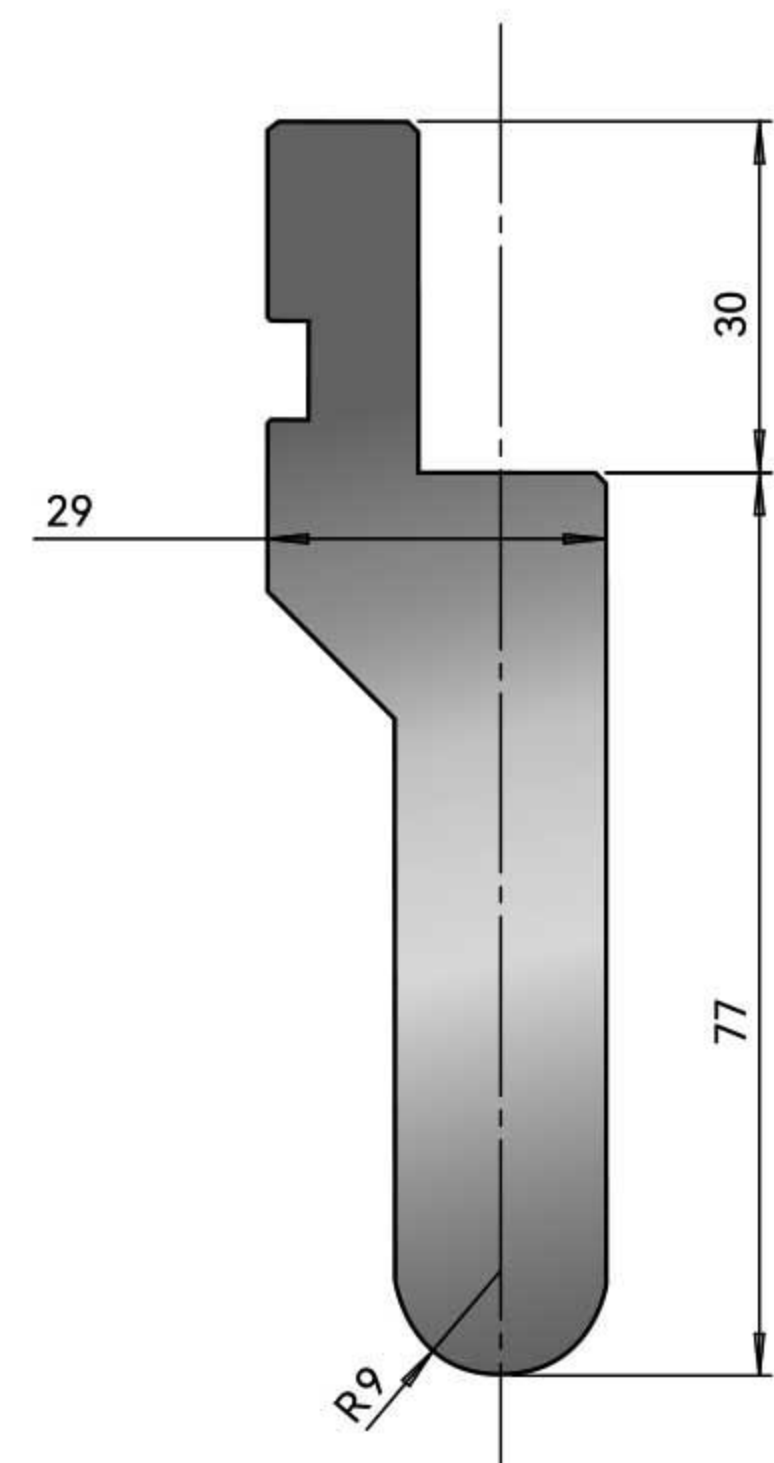

ZEP.RD09

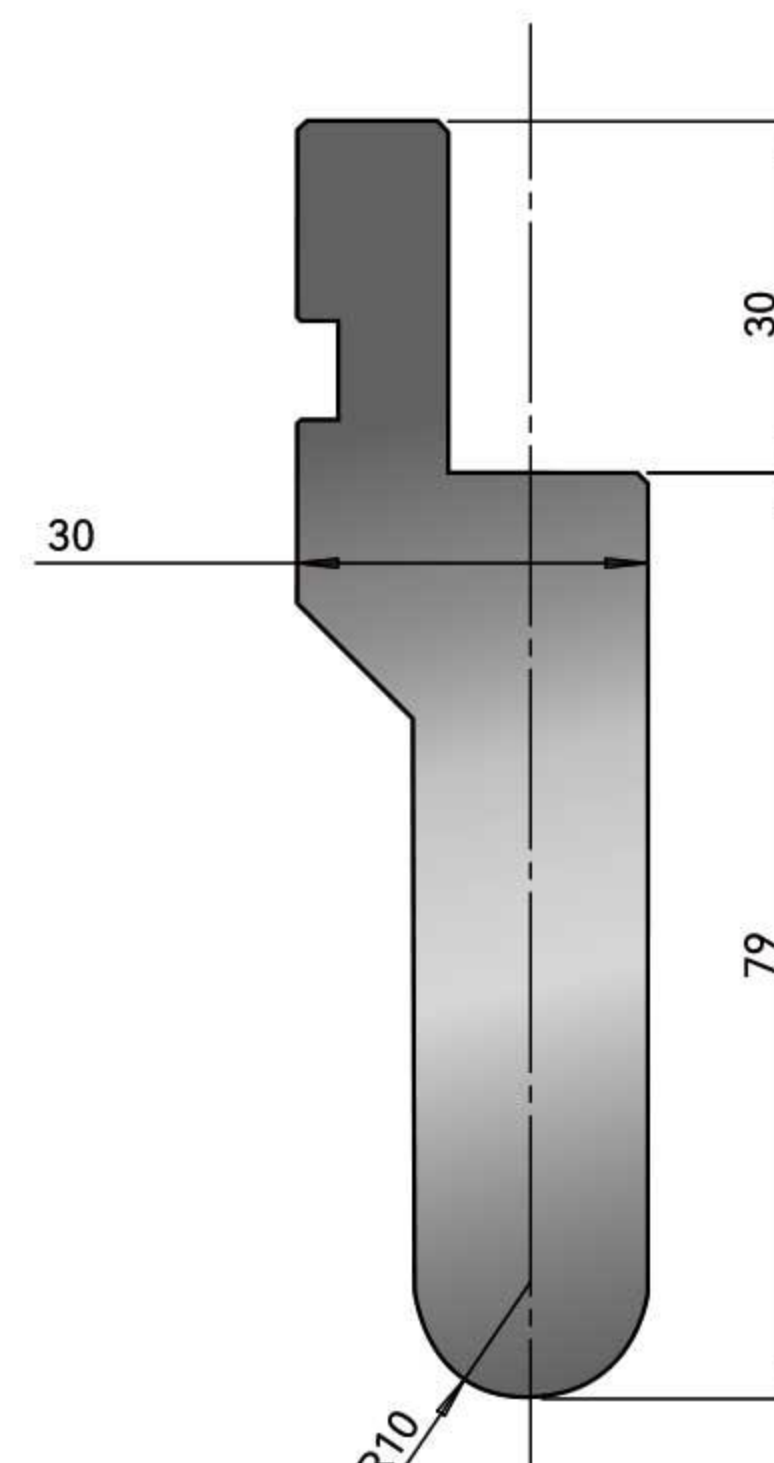

ZEP.RD10

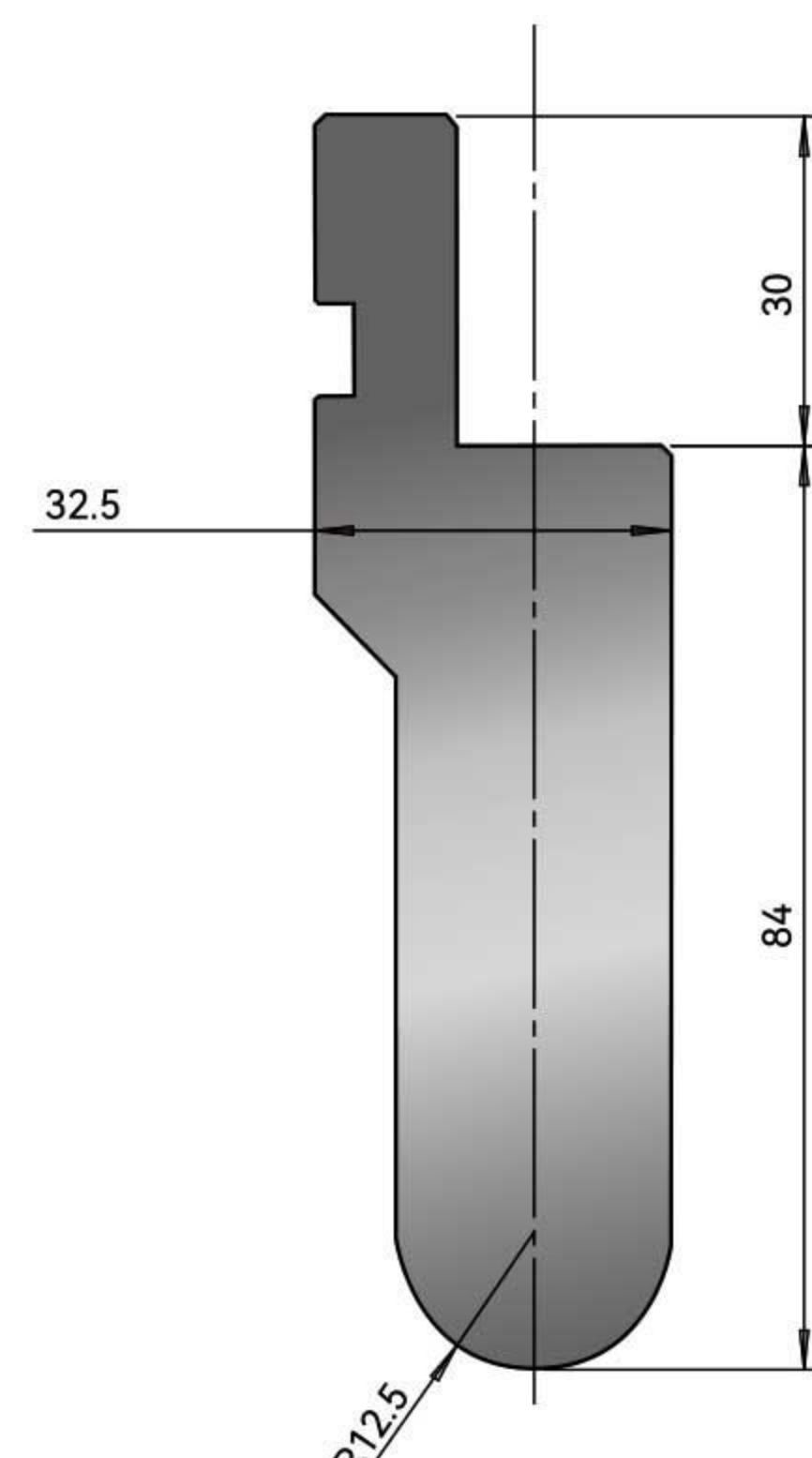

ZEP.RD13

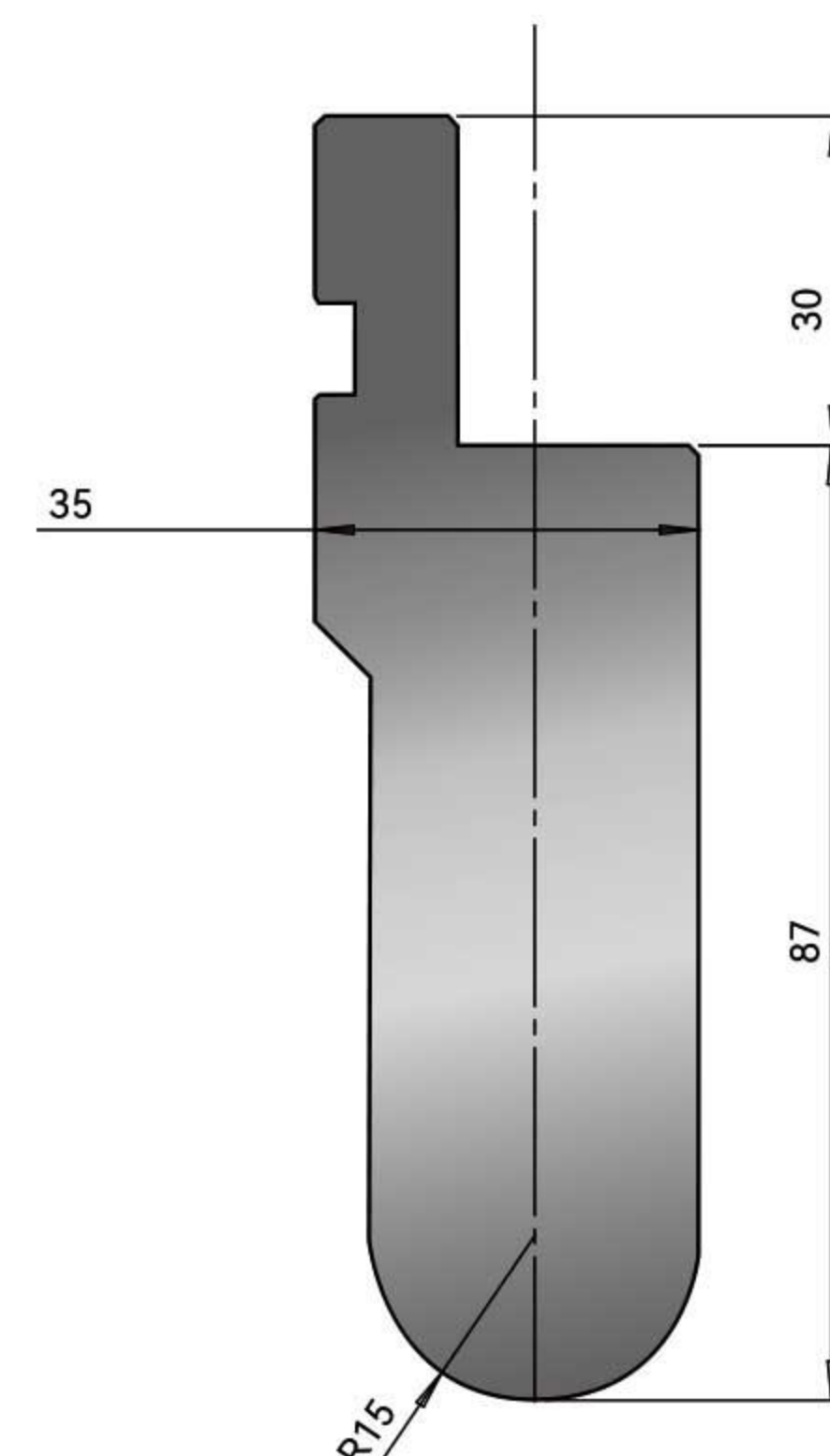

ZEP.RD15

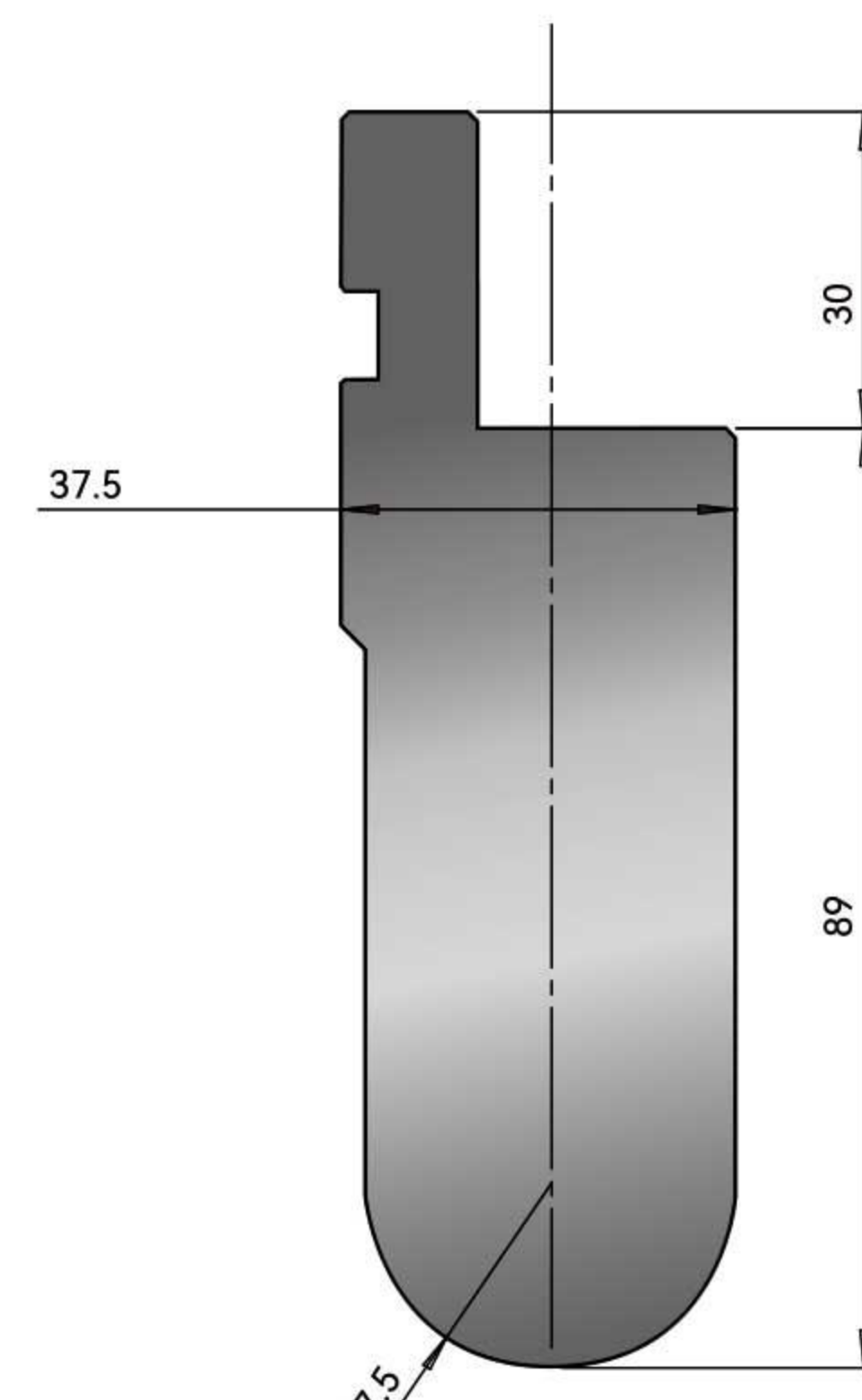

ZEP.RD18

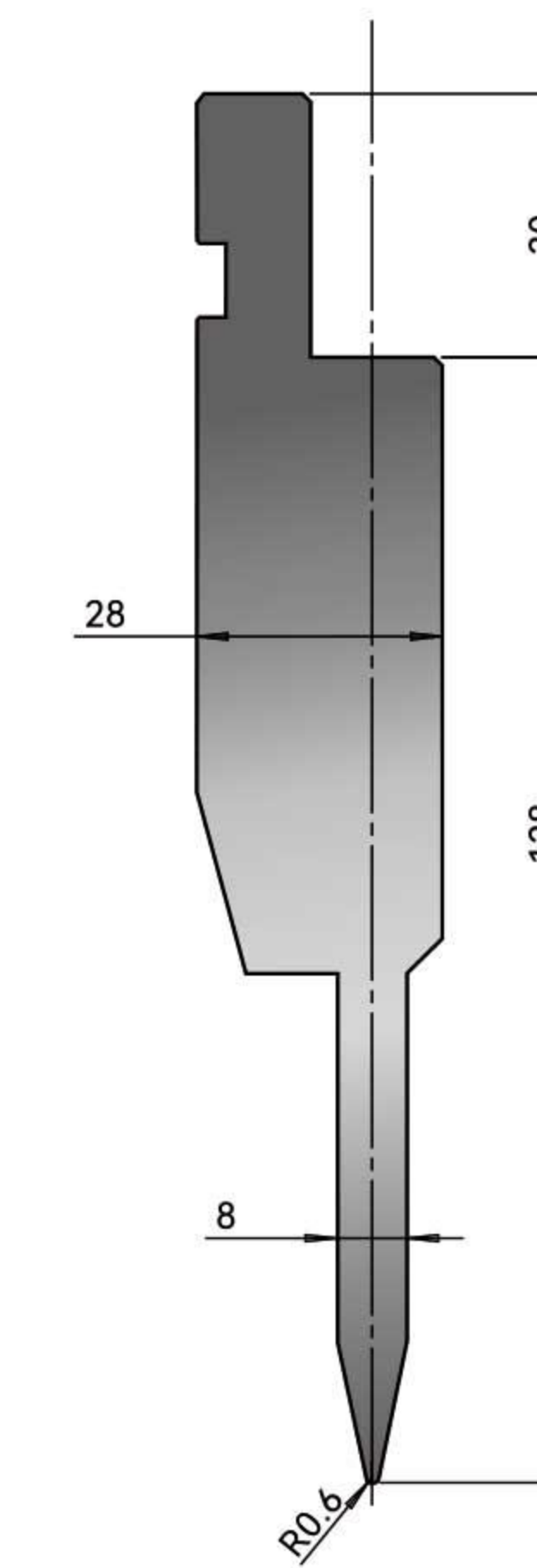

ZEP.HP08

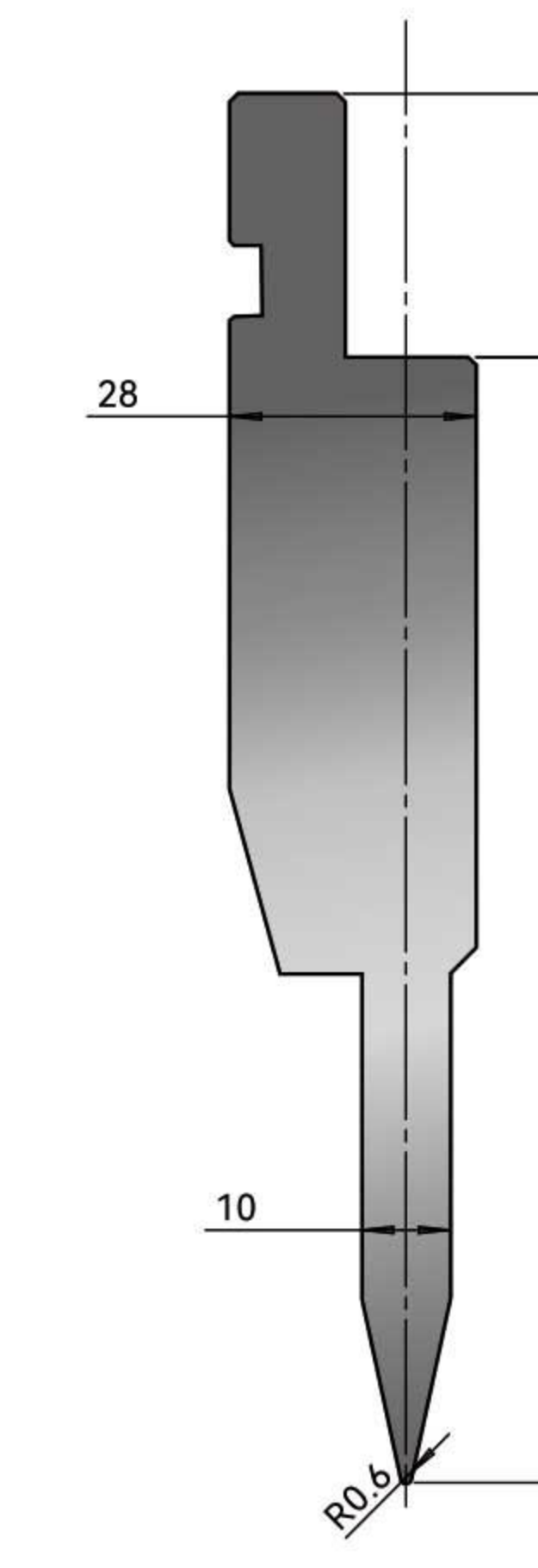

ZEP.HP10

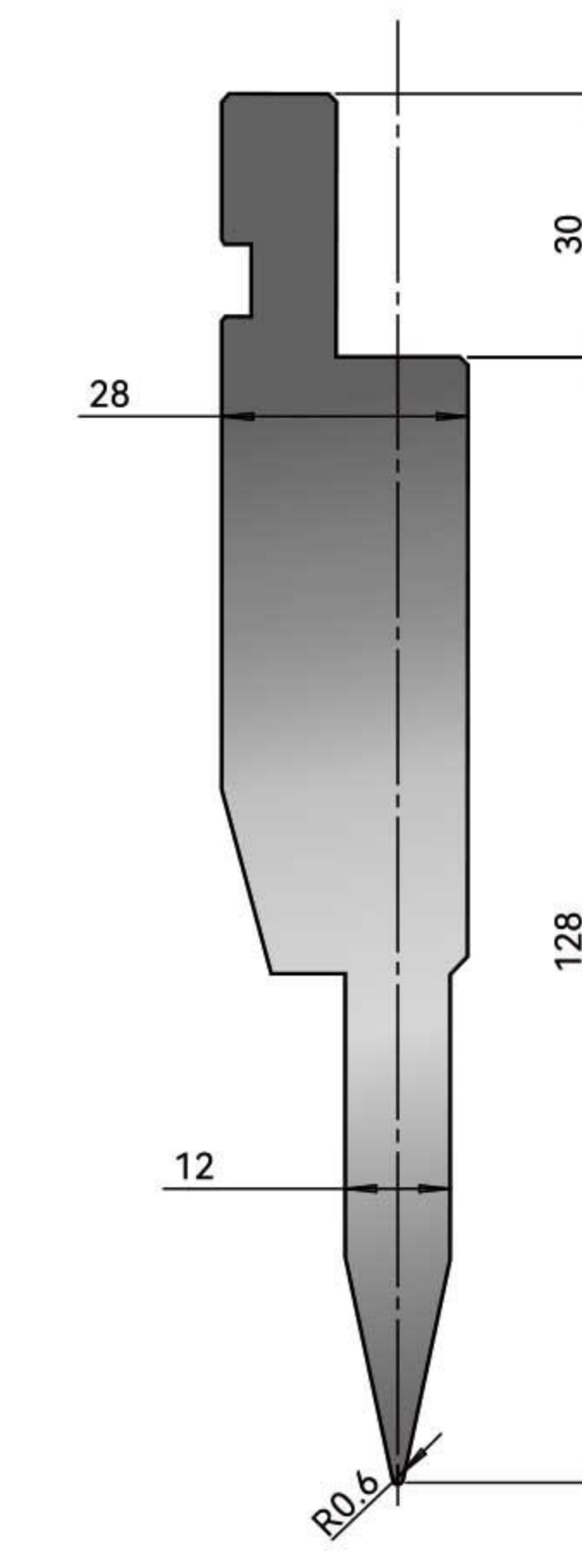

ZEP.HP12

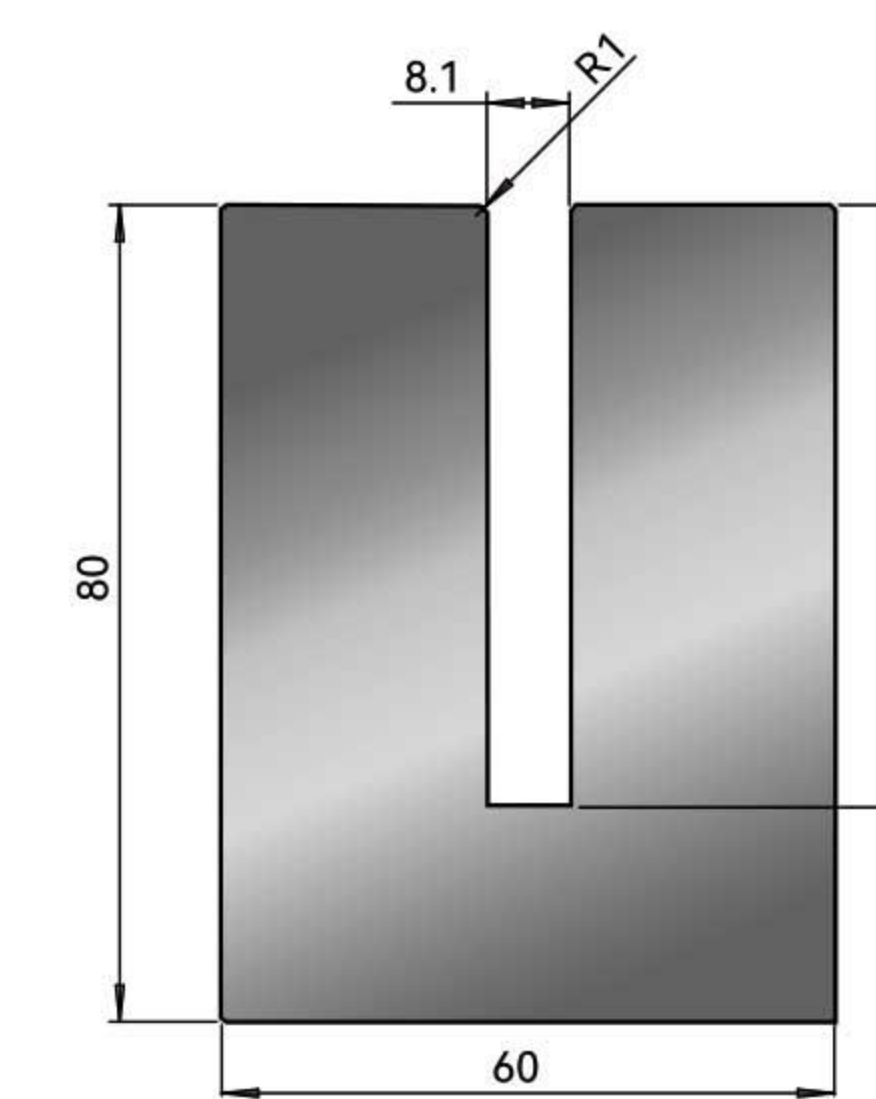

ZED.HD08

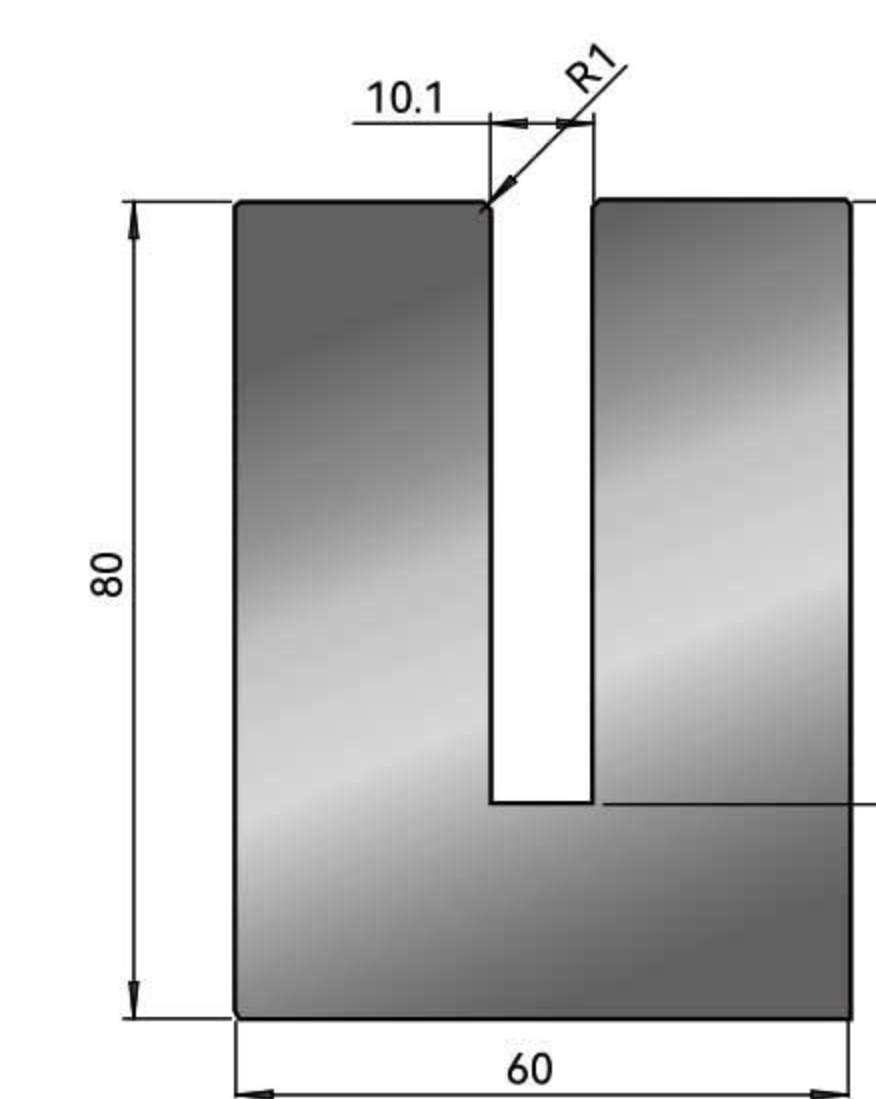

ZED.HD10

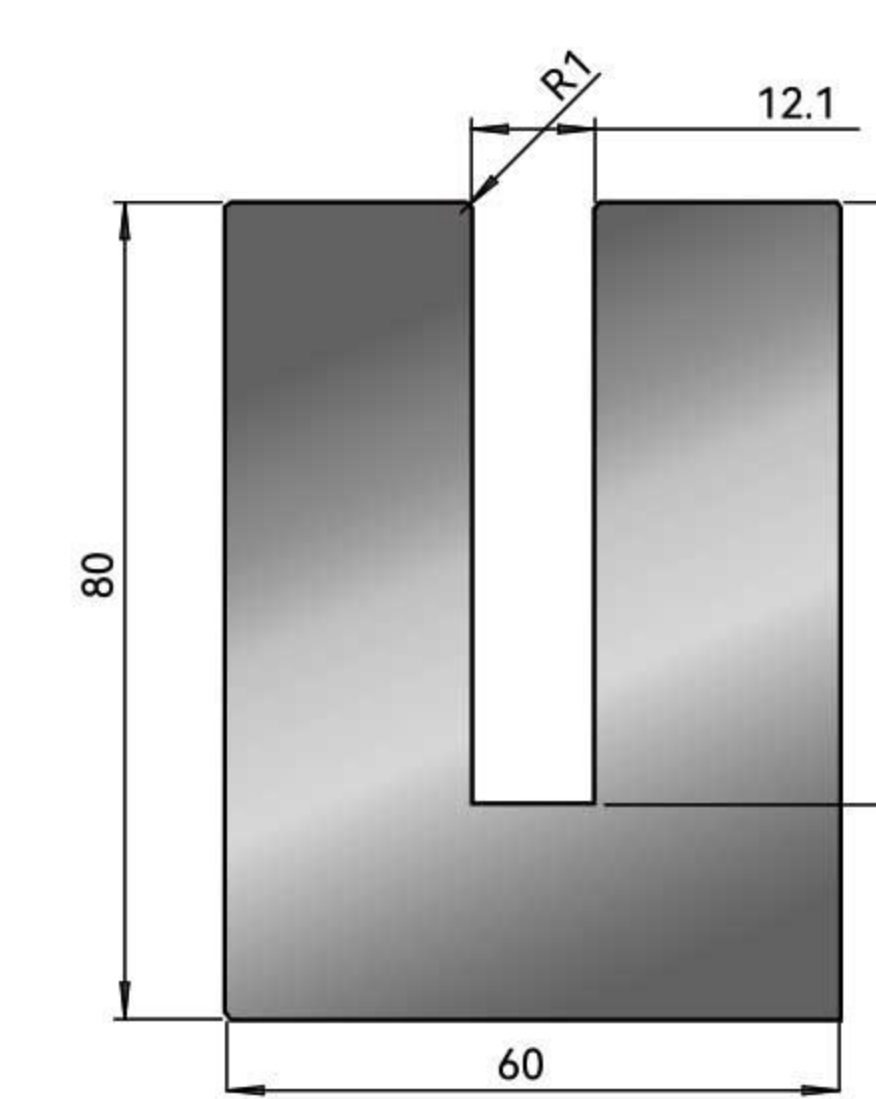

ZED.HD12

GUNNARPRESS CAT.NO	Radius	H	Max Loading (t/m)	Weight(kg/m)
ZEP.RD08	8	77	100	14
ZEP.RD09	9	77	100	15
ZEP.RD10	10	79	100	16
ZEP.RD13	12.5	84	100	20
ZEP.RD15	15	87	100	23
ZEP.RD18	17.5	89	100	27

GUNNARPRESS CAT.NO	Radius	H	Max Loading (t/m)	Weight(kg/m)
ZEP.HP08	0.6	128	80	21
ZEP.HP10	0.6	128	80	22
ZEP.HP12	0.6	128	80	23
ZED.HD08	1	59	50	34
ZED.HD10	1	59	50	33
ZED.HD12	1	59	50	32



Hemming Spring Load Die

PRESS BRAKE TOOLS-BENDMAX-EUROPEAN STYLE

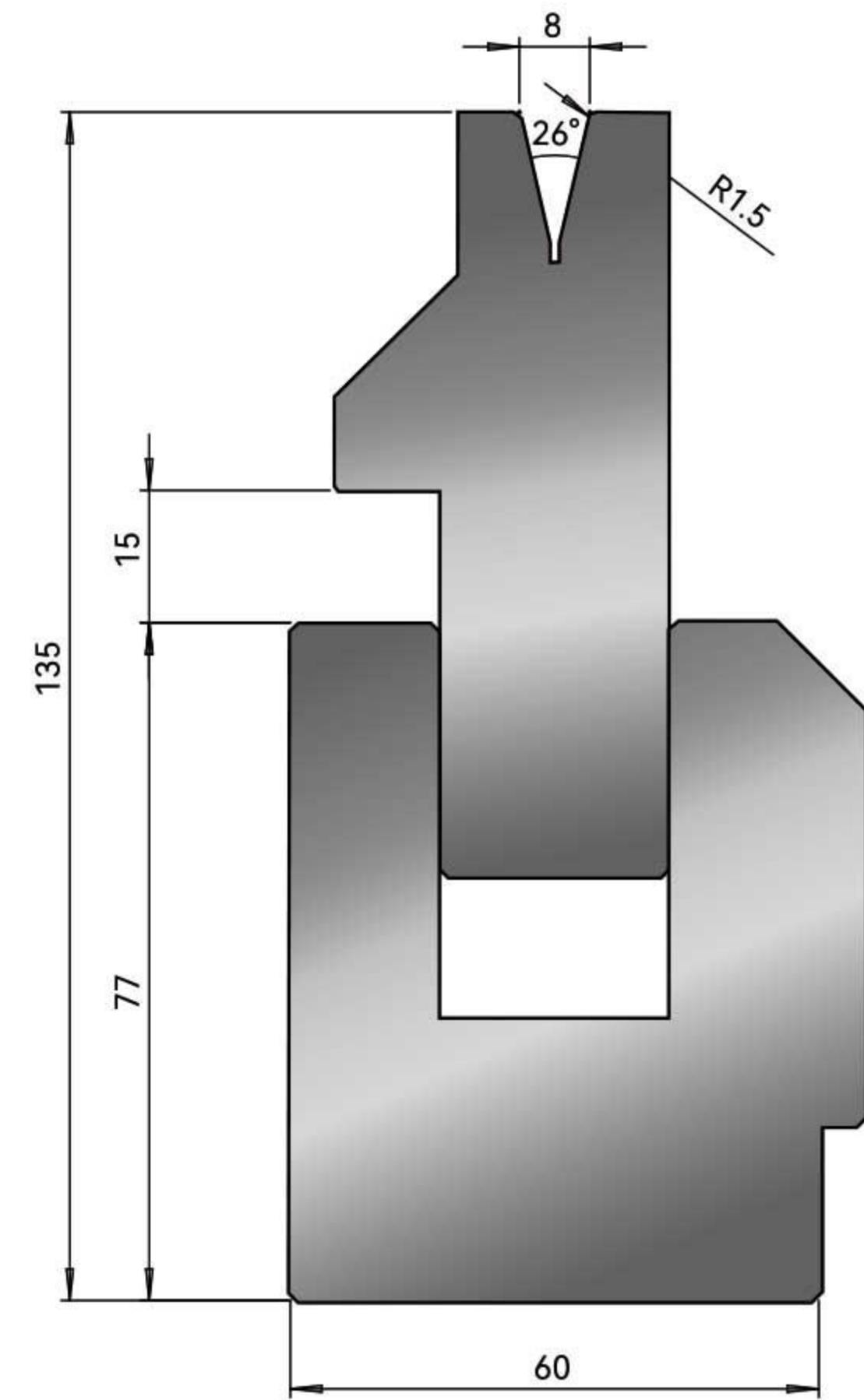

BENDMAX CAT.NO	Max Loading (t/m)	Weight(kg/m)
ZED.HD.SL26V8	100	18

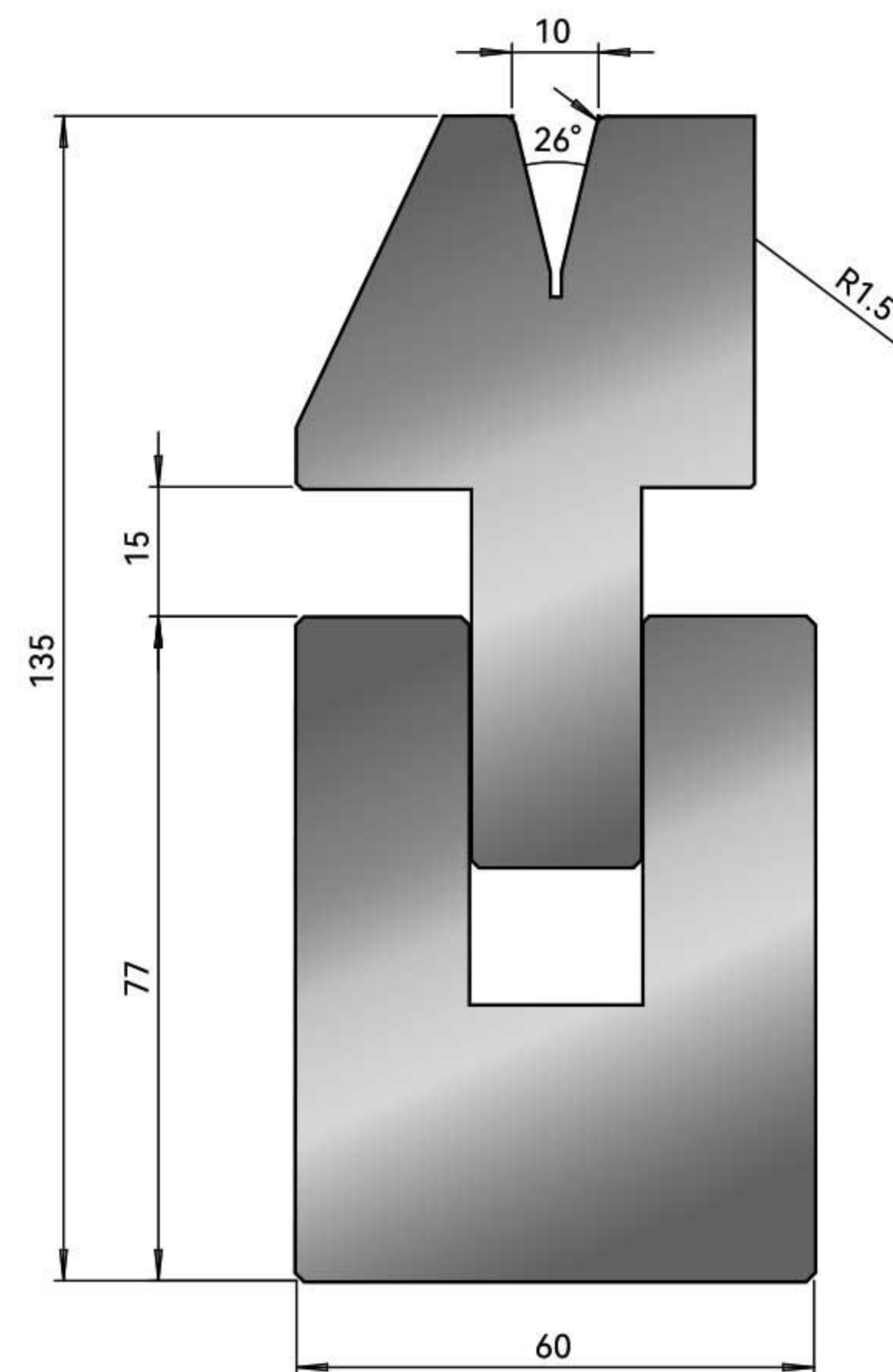

BENDMAX CAT.NO	Max Loading (t/m)	Weight(kg/m)
ZED.HD.SL26V10	100	19.5

PRESS BRAKE TOOLS-BENDMAX-EUROPEAN STYLE

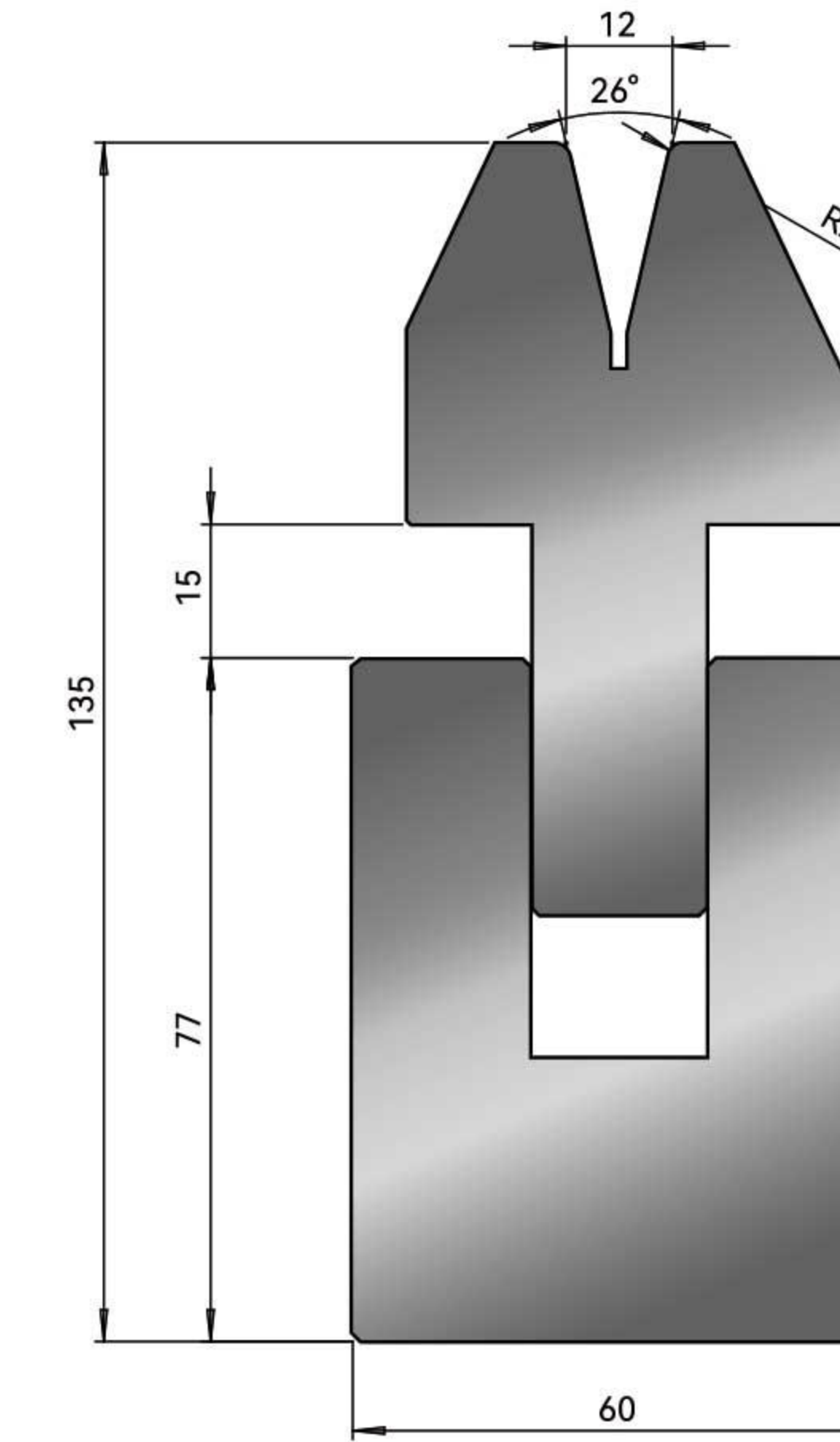

BENDMAX CAT.NO	Max Loading (t/m)	Weight(kg/m)
ZED.HD.SL26V12	100	19

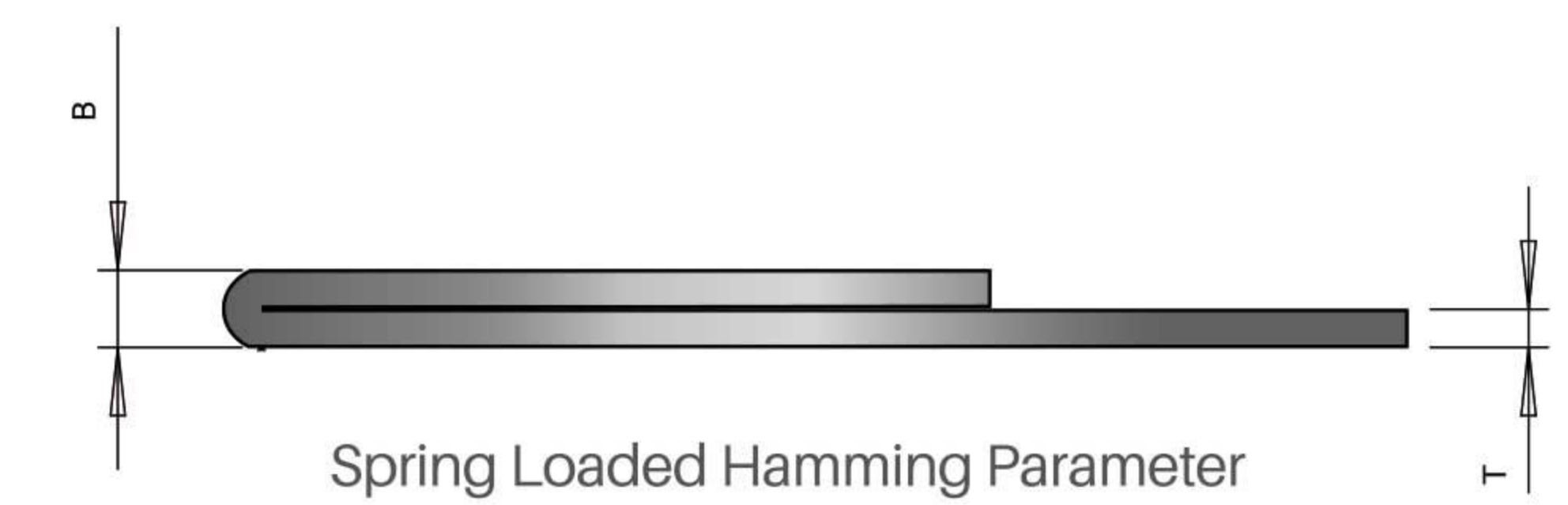
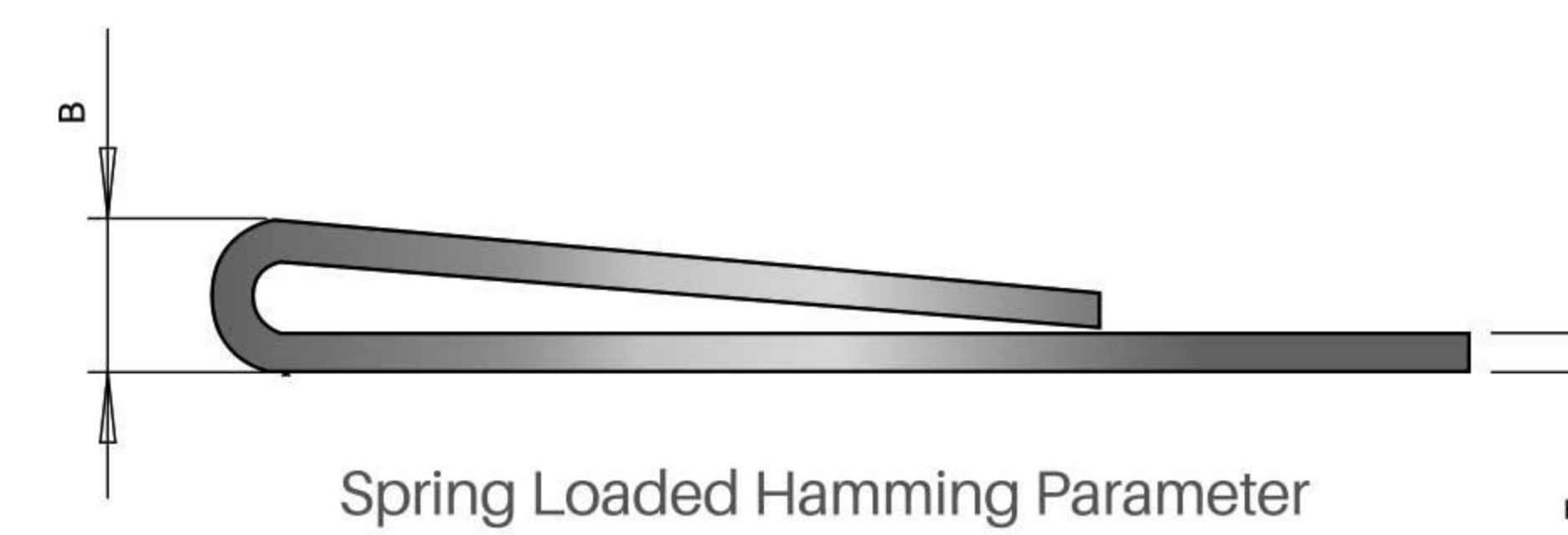

T(mm)	B	Rm450 n/mm ² t/m	Rm700 n/mm ² t/m
0.6	3.0	90	150
0.8	3.0	120	200
1.0	3.5	150	250
1.2	3.5	170	300
1.5	4.6	220	380
2.0	5.5	300	500
2.5	6.5	550	900
3.0	8.0	700	1000

T(mm)	B	Rm450 n/mm ² t/m	Rm700 n/mm ² t/m
0.6	1.2	230	350
0.8	1.6	320	500
1.0	2.0	400	600
1.2	2.4	500	800
1.5	2.0	630	950
2.0	4.0	800	1300
2.5	5.0	900	1800
3.0	6.0	1000	2100

Air Bending Force Table

AIR BENDING FORCE TABLE

Bending force at required 90° air press

AIR BENDING V OPENING CALCULATION RULE

Aluminium	=0.5*F
Stainless steel	=1.5*F

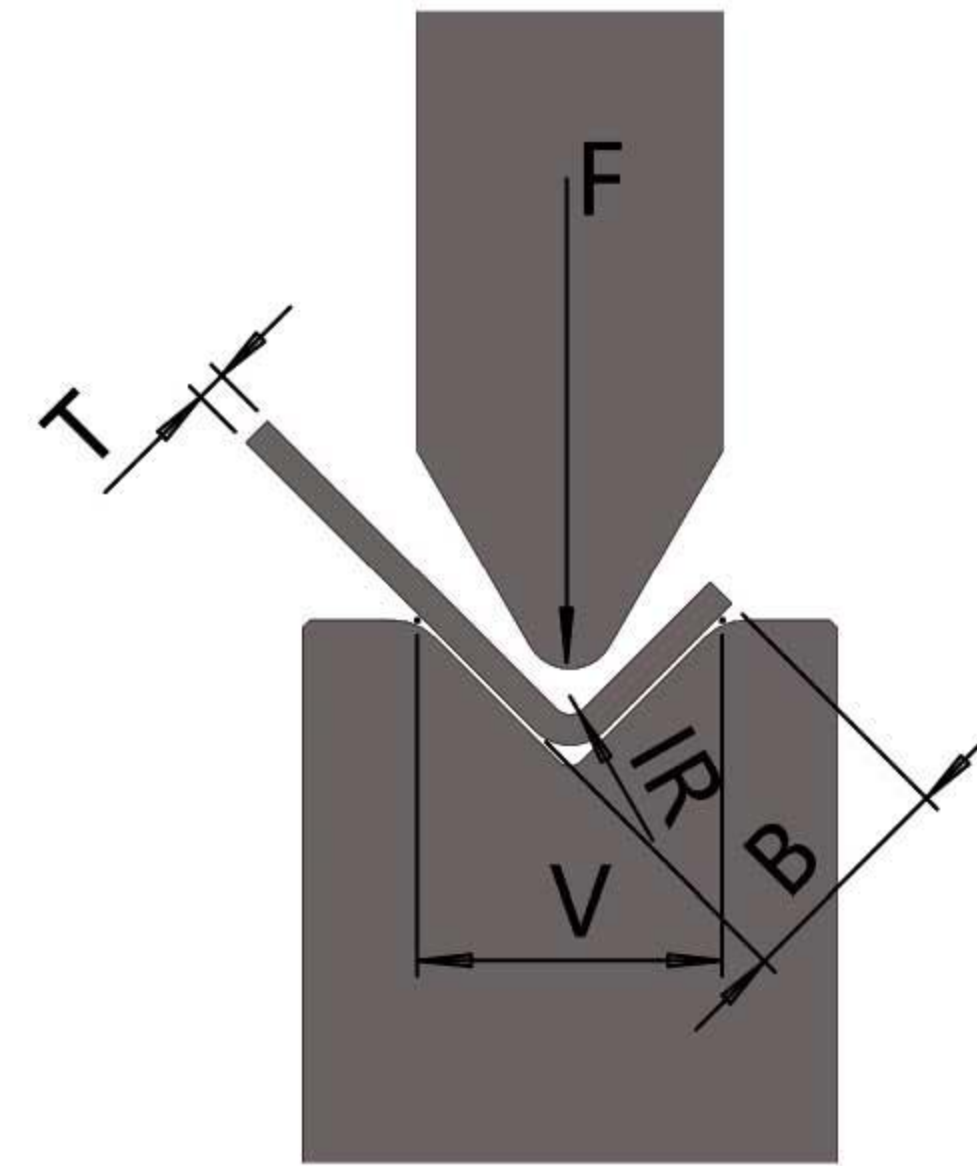

- T=Material thickness
- B=Minimum flange
- IR=Inside radius
- F=Bend force per meter (kN/m)
- V=Die V opening

AIR BENDING V OPENING CALCULATION RULE

Recommended Die V opening

Material thickness	0.75-2.5mm	3-8mm	9-10mm	>12mm
Die V opening	6*T	8*T	10*T	12-15*T

Material: 450N/mm² (Mild Steel)

V(mm)	6	68	10	12	16	20	24	30	40	50	60	70	80	90	100	120	
B(mm)	4.5	6	7.5	9	12	15	18	22.5	30	37.5	45	52.5	60	67.5	75	90	
IR(mm)	1	1.3	1.6	1.9	2.6	3.2	3.8	4.8	6.4	8	9.6	11	13	14	16	19	
0.75	52	39	31	26													
1	93	70	56	47	35												
1.25	145	109	87	73	55	44											
1.5	209	157	126	105	79	63											
1.75		214	171	143	107	86	71										
2			223	186	140	112	93										
2.5				291	218	175	145	116									
3					314	251	209	168	126								
3.5					428	342	285	228	171	137							
4						447	372	298	223	179	149						
4.5						566	471	377	283	226	189	162					
5								466	349	279	233	200	175				
6								670	503	402	335	287	251	223			
7									684	547	456	391	342	304	274		
8										715	596	511	447	397	358		
10												798	698	621	559	466	
12														1005	894	804	670

Coordinate Measuring Machine

HIGH QUALITY REQUIREMENT OF CLIENTS

Knowing the high quality requirement of clients, not only demands the precision and quality in the production process, but reinforced the inspection of half and finished products during production and before shipment.

